



# Parts Manual

Mfg. No: 5901887  
FW25 Series w/ 48" Mower Deck  
(FW25KAV1948)

5600859 - Kit, Weight Bracket, W25.....  
5600267 - KIT, BAGGER, 48/52, WB (3.75 BUSHEL).....  
5600861 - Kit, Bagger Counter Spring, W25.....  
5600582 - Mulch Kit for ZTR & WALK w/ 48" Deck - S/N: 2015355958 & Above.....  
5600563 - Mulch Kit for WALK w/ 48" Deck - S/N: 2015355957 & Below.....  
5105070 - Catcher, Steel Frame / Aluminum Mesh.....  
5105072 - Mounting Kit, Catcher for 48" Decks (FW25, SW25, FW35, SW35).....

Not For  
Reproduction

<b>Model Components</b>	<b>Page</b>
48" & 52" Mower Deck - Rollers.....	4
48" Mower Deck - Housing, Covers, Spindles & Blades.....	6
48" Mower Deck - Pulleys, Belt & Idler Arm S/N: 2017170235 & Above.....	8
Decal Group - Brand & Model S/N: 2017246271 & Above.....	10
Decal Group - Safety & Operation USA Models.....	12
Deck Lift Group.....	14
Electrical Group.....	16
Electrical Schematic - Charging Circuit Electric Start S/N: 2017954956 & Above.....	20
Electrical Schematic - Cranking Circuit Electric Start S/N: 2017954956 & Above.....	22
Electrical Schematic - Engine Op. Pres. Circuit Electric Start S/N: 2017954956 & Above.....	24
Electrical Schematic - PTO Op. Pres. Circuit Electric Start S/N: 2017954956 & Above.....	26
Engine & PTO Group.....	28
Engine Service Parts - Kawasaki (FS481V - FS730V).....	30
Fuel Tank & Mount, Fuel Supply, and EVAP Group (No Canister).....	32
Handle Bar & Instrument Control Group.....	34
Hydraulic Group.....	36
Main Frame & Front Caster Group.....	38
Motion Control Group - Lower.....	40
Motion Control Group - Spring Assemblies.....	42
Motion Control Group - Upper (Standard Controls).....	44
Parking Brake Group.....	48
Spindle SERVICE PARTS - 5061095.....	50
Transaxle Drive Group.....	52
Transaxle SERVICE PARTS - ZT3100.....	54
Wheel & Tire Group.....	56
Torque Specification Chart.....	58

# 48" & 52" Mower Deck - Rollers

Note: Unless noted otherwise, use the standard torque specifications

Mfg. No: 5901887

5302697W25

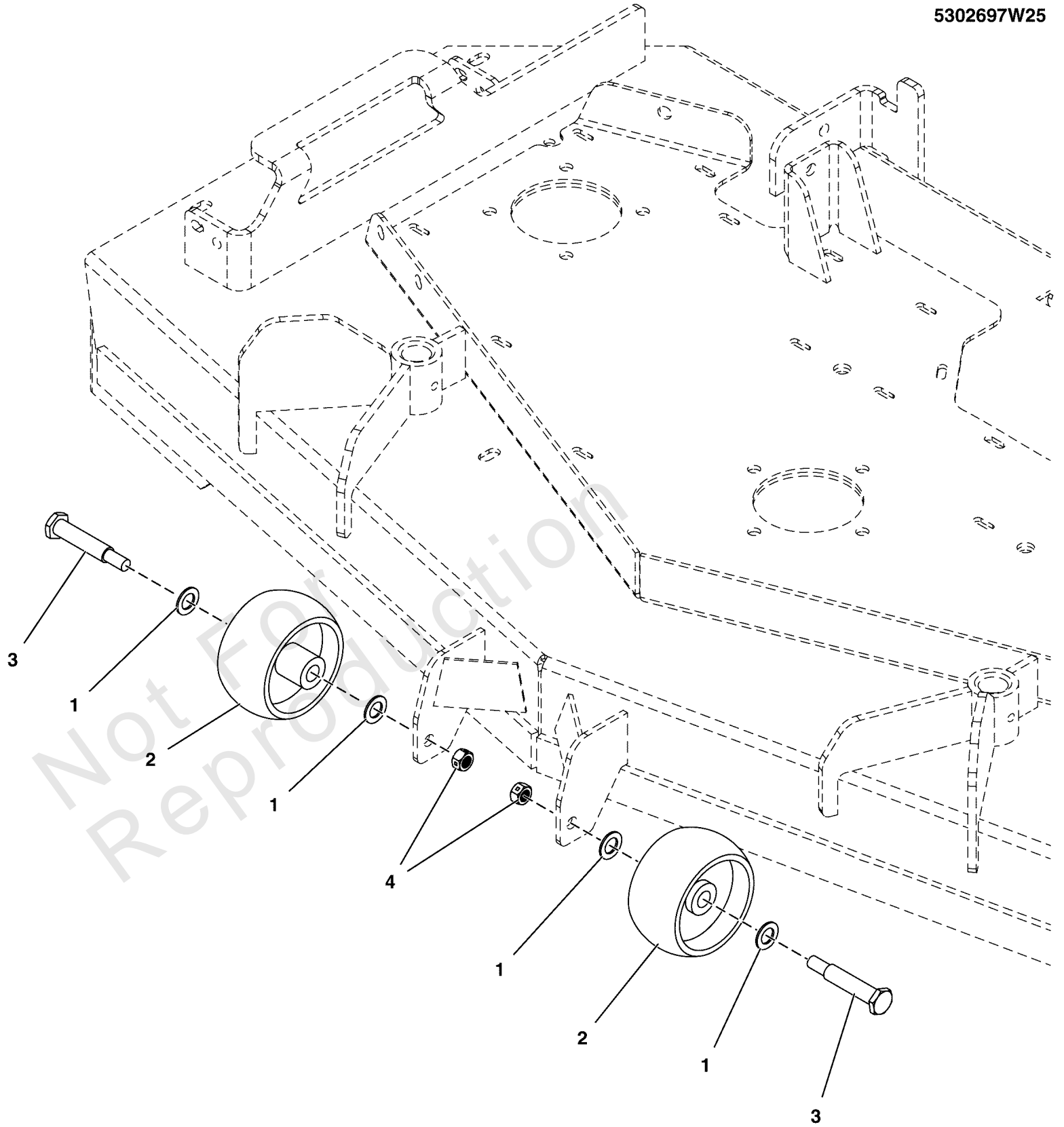

## 48" & 52" Mower Deck - Rollers

REF NO	PART NO	QTY	DESCRIPTION
1	80003590	4	WASHER,.516IDX.875ODX.06,FLAT,ZC/CL
2	1714760	2	WHEEL- 2.00 WIDE 3.88 DIA 0.531ID POLY
3	2108765	2	BOLT-WHEEL 3/8-16X2.781 .750 THRD
4	5025100	2	NUT, 3/8-16 HEX SIDE LOCK

Not For Reproduction

# 48" Mower Deck - Housing, Covers, Spindles & Blades

Note: Unless noted otherwise, use the standard torque specifications

Mfg. No: 5901887

5304044  
5303861  
5304322  
5304323

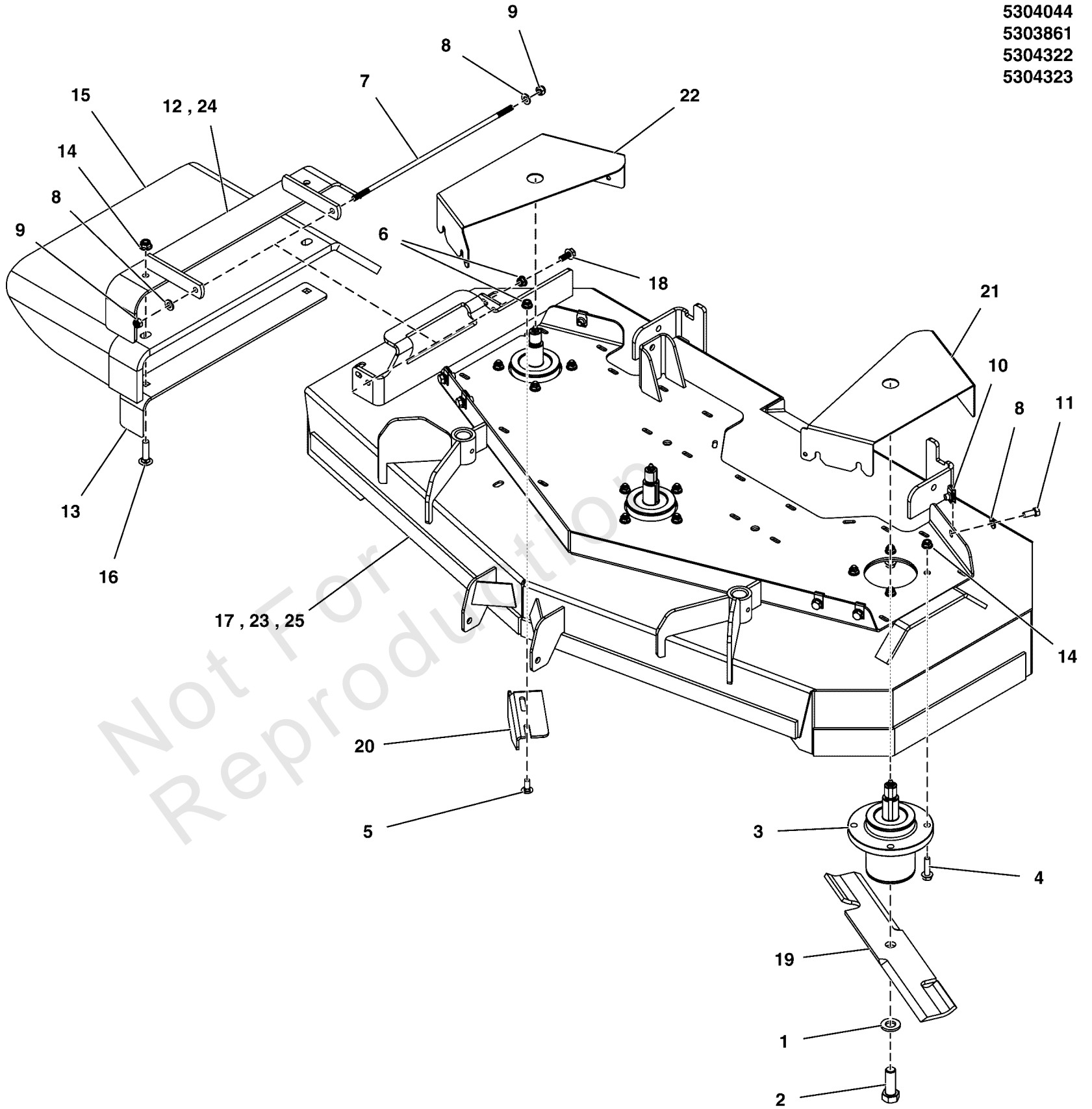

## 48" Mower Deck - Housing, Covers, Spindles & Blades

REF NO	PART NO	QTY	DESCRIPTION
1	5025477	3	WASHER, BLADE BOLT, 9/16" F436, CZ
2	5025320X14	3	BOLT, 5/8-11 X 1-3/4 GD8
3	5061095	3	SPINDLE, ASSM, ALUMINUM - 5.25
4	5025390X10	12	BOLT, 3/8-16 X 1-1/4, FLANGE, GD5, CZ
5	5025145X6	2	BOLT, 5/16-18 X 3/4, CARRIAGE
6	5025392	3	NUT, 5/16-18 HEX NYLOCK FLANGE
7	5042555	1	ROD, 5/16 X 13.75, TBE, CZ
8	5025155	8	WASHER, 5/16" SAE
9	5025045	2	NUT, 5/16-24 HEX NYLON LOCK
10	5022308	6	BODY CLIP, 5/16-18-7GA MATERIAL
11	5025011X6	6	BOLT, 5/16-18 X 3/4 GD5
12	5413404A	1	WELD, MOUNT, DISCHARGE CHUTE - BLK -(S/N: 2017555756 & Below)
13	5413401A	1	SUPPORT, DISCHARGE CHUTE - BLK
14	5025394	14	NUT, 3/8-16 HEX NYLOCK FLANGE
15	5413498	1	CHUTE, RUBBER DISCHARGE CHUTE (5104441)
16	5025146X12	2	BOLT, 3/8-16 X 1-1/2, CARRIAGE, GD5, CZ
17	5600851	1	DECK SHELL W/DECALS, 48, FW25 (5412960B) -(S/N: 2017170234 & Below)
18	5025011X6	1	BOLT, 5/16-18 X 3/4 GD5
19	5101986S	1	BLADES, SET OF THREE (3); 16.25 X.25 X 2.5, 1 X 3.5
20	5401344A	1	PLATE, DEFLECTOR - BLK
21	5413006B	1	GUARD, DECK, 48, LH - RED
22	5413005B	1	GUARD, DECK, 48, RH - RED
23	5600895	1	DECK SHELL W/ DECALS, 48, FW25 (5414518B) -(S/N: 2017170235 & 2017555756)
24	5413403A	1	WELD, MOUNT, DISCHARGE CHUTE - BLK -(S/N: 2017555757 & Above)
25	5601007	1	DECK SHELL W/DECALS, FW25-48 (5415572B) -(S/N: 2017555757 & Above)

# 48" Mower Deck - Pulleys, Belt & Idler Arm S/N: 2017170235 & Above

Note: Unless noted otherwise, use the standard torque specifications

Mfg. No: 5901887

5304046A  
5304298A

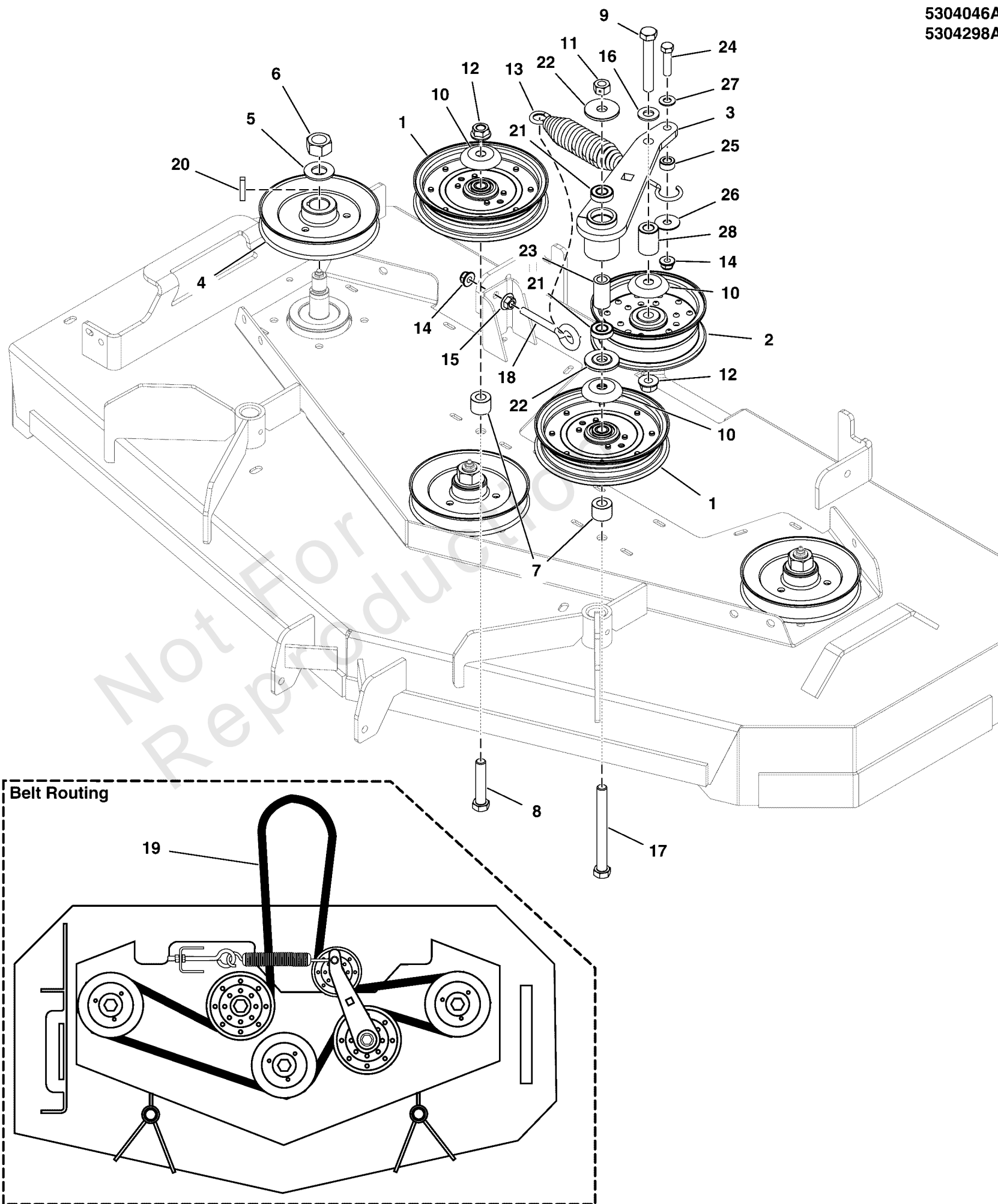



## 48" Mower Deck - Pulleys, Belt & Idler Arm S/N: 2017170235 & Above

REF NO	PART NO	QTY	DESCRIPTION
1	-----	2	Replace with: Pulley #5104717 & Debris Shield #5105145
2	5101312	1	PULLEY, IDLER, 5.00 WIDE W/ .51 BORE
3	5414690A	1	WELD, IDLER ARM, 7.50, BEARING - BLK
4	5023175	3	PULLEY, 5.540OB X .985ID, SINGLE B-SEC
5	5025406	3	WASHER, 3/4 BELLEVILLE CL/ZC
6	5025405	3	NUT, 3/4-16 Hex
7	5046916	2	SPACER, .51 x 1.75 x .75
8	5025017X20	1	BOLT, 1/2-13 X 2-1/2" GD5 CZ
9	5025017X26	1	BOLT, 1/2-13 X 3-1/4, HEX HD, GD5, CZ (SV)
10	5101103	3	SHIELD, PULLEY BEARING, CZ
11	5025332	1	NUT, 1/2-13 Hex Side Lock
12	5025396	2	NUT, Hex Flange, Nylock, 1/2-13
13	5100632	1	SPRING-EXT, 1.25OD X 9.3LG X .142WR, BLK
14	5025394	2	NUT, 3/8 - 16 HEX NYLOCK FLANGE
15	5025128	1	NUT, 3/8-16 Hex Large Serrated Flange
16	5025158	1	WASHER, 1/2 SAE
17	5025017X40	1	BOLT, 1/2-13 X 5" GD5 YZ
18	5025429	1	EYEBOLT, 3/8-16 X 4, 2.13THRD, .75EYE, C
19	5104393	1	BELT, B-SEC, 129.15"EL, ARAMID, WRAPED
20	5050407X10	3	KEY, 1/4" SQ. X 1-1/4
21	7078243	2	BEARING, BALL, AXLE
22	5103262	2	SPACER, IDLER ARM, 1/2, PM
23	5103812	1	SPACER, .52 X .84 X 1.53, PM
24	5025013X12	1	BOLT, 3/8-16 X 1-1/2" GD5 CZ
25	5044933	1	SPACER, .39 X .75 X .38, PM, CZ
26	5025165	1	WASHER, 3/8" Fender
27	5025156	1	WASHER, 3/8 SAE
28	5101207	1	SPACER, .52 X 1.00 X 1.38 YZ

Decal Group - Brand & Model S/N: 2017246271 & Above

Note: Unless noted otherwise, use the standard torque specifications

Mfg. No: 5901887

- 5304040
- 5304042
- 5304133
- 5304134
- 5304334
- 5304335

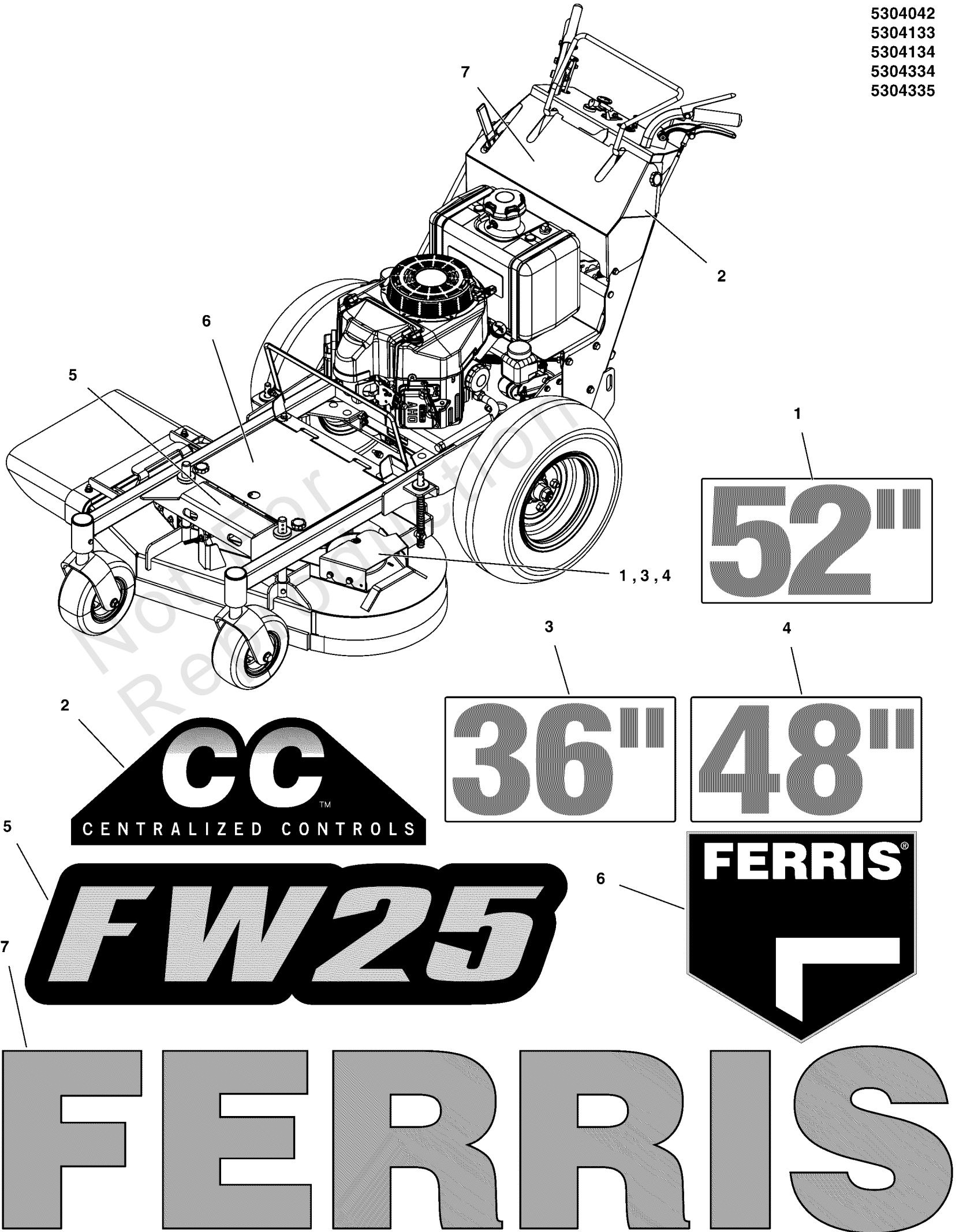

**Decal Group - Brand & Model S/N: 2017246271 & Above**

REF NO	PART NO	QTY	DESCRIPTION
1	5022812	1	DECAL, 52 -(52" Models)
2	5104518	1	DECAL, CENTRALIZED CONTROLS -(Models with Centralized Controls Only)
3	5101322	1	DECAL, 36 -(36" Models)
4	5022811	1	DECAL, 48 -(48" Models)
5	5104765FS	1	DECAL, MODEL
6	5104755FS	1	DECAL, BRAND
7	5103799	1	DECAL, FERRIS, 2.23" X 11.39"

Not For Reproduction

# Decal Group - Safety & Operation USA Models

Note: Unless noted otherwise, use the standard torque specifications

Mfg. No: 5901887

5304038

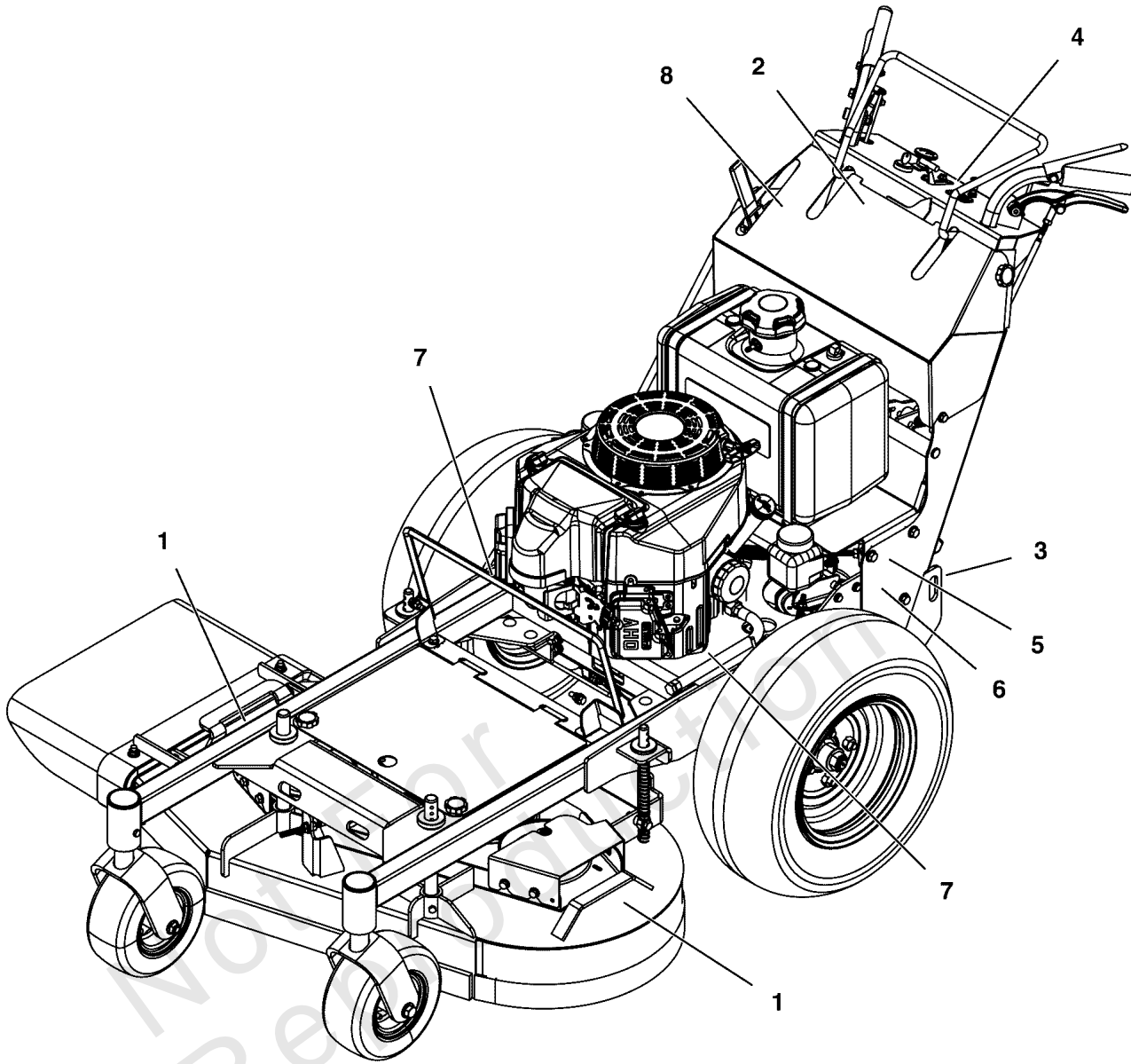

**WARNING**

**Fire Hazard**  
Gasoline is flammable. Debris is combustible.

- Allow engine to cool for at least 3 minutes before refueling.
- Keep unit cleaned of debris
- This equipment may create sparks that can start fires around dry vegetation. A spark arrester may be required. Contact local fire agencies for regulations relating to fire prevention requirements.

5103665

The operator's manual is available in Spanish. La manual del operador está disponible en Español. 5104589

**Ignition System (Gasoline Models)**  
This spark ignition system complies with Canadian standard ICES-002.

**⚠ DANGER**

**Amputation and thrown objects hazard**

- Keep hands and feet away from deck.
- Do not operate mower unless discharge chute or entire grass catcher is in its proper place.

719165

**⚠ WARNING**

**Avoid serious injury or death**

- Read operator's manual before using this product.
- Go across slopes, NOT up and down, while backing.
- Stop the mower when children or others are near.
- Remove objects that could be thrown by the blade.
- Keep safety devices (guards, shields, switches, etc.) in place and working.
- Do NOT operate this machine unless you are trained.
- Know the location and function of all controls.
- Avoid steep slopes. Reduce speed and use extreme caution on slopes.

5100465

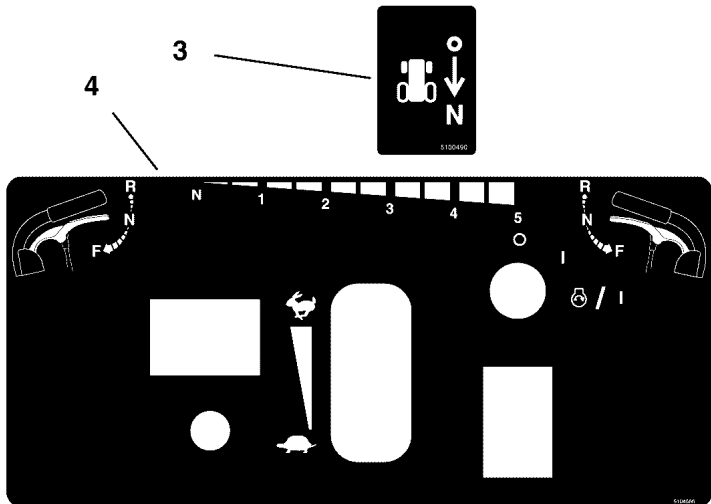
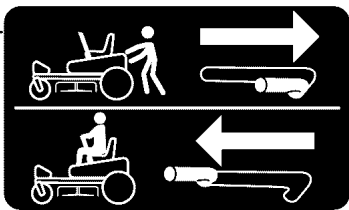

**⚠ DANGER**

**Falling Off Sulky Hazard**

- Read the Operator's Manual.
- Follow all Safety Rules and Information.
- Do NOT operate on slopes over 20 degrees.

**Crushing Hazard of Sulky - It May Cause Serious Injury**

- Do NOT allow sulky to rotate more than 90 degrees while standing on sulky platform.
- Do NOT operate in reverse (back up) while standing on sulky platform, always dismount sulky.
- Always place sulky in transport position (secured by the chain) before loading or unloading mower on a trailer.

5106763

## ***Decal Group - Safety & Operation USA Models***

<b>REF NO</b>	<b>PART NO</b>	<b>QTY</b>	<b>DESCRIPTION</b>
1	7101665	2	DECAL, DANGER DO NOT OPERATE W/O DEFLECT
2	5103601	1	DECAL, WARNING, WALKS
3	5100490	2	DECAL, PEDAL
4	5104566	1	DECAL, DASH PANEL, WKB, MAN/ELEC START
5	5103665	1	DECAL, FIRE HARARD, 3.25W X 3.0H
6	5104269	1	DECAL, SPANISH MANUAL, IGES, C-TICK
7	5104268	2	DECAL, TRANSAXLE RELEASE, WB
8	5102628	1	DECAL, PARKING BRAKE SYMBOLS
9	5106760	1	DECAL, MAIN SAFETY, SULKY -(S/N: 4000036919 & Above)(Located on the rear of the engine deck.)

Not For Reproduction

# Deck Lift Group

Note: Unless noted otherwise, use the standard torque specifications

Mfg. No: 5901887

5303914  
5303855

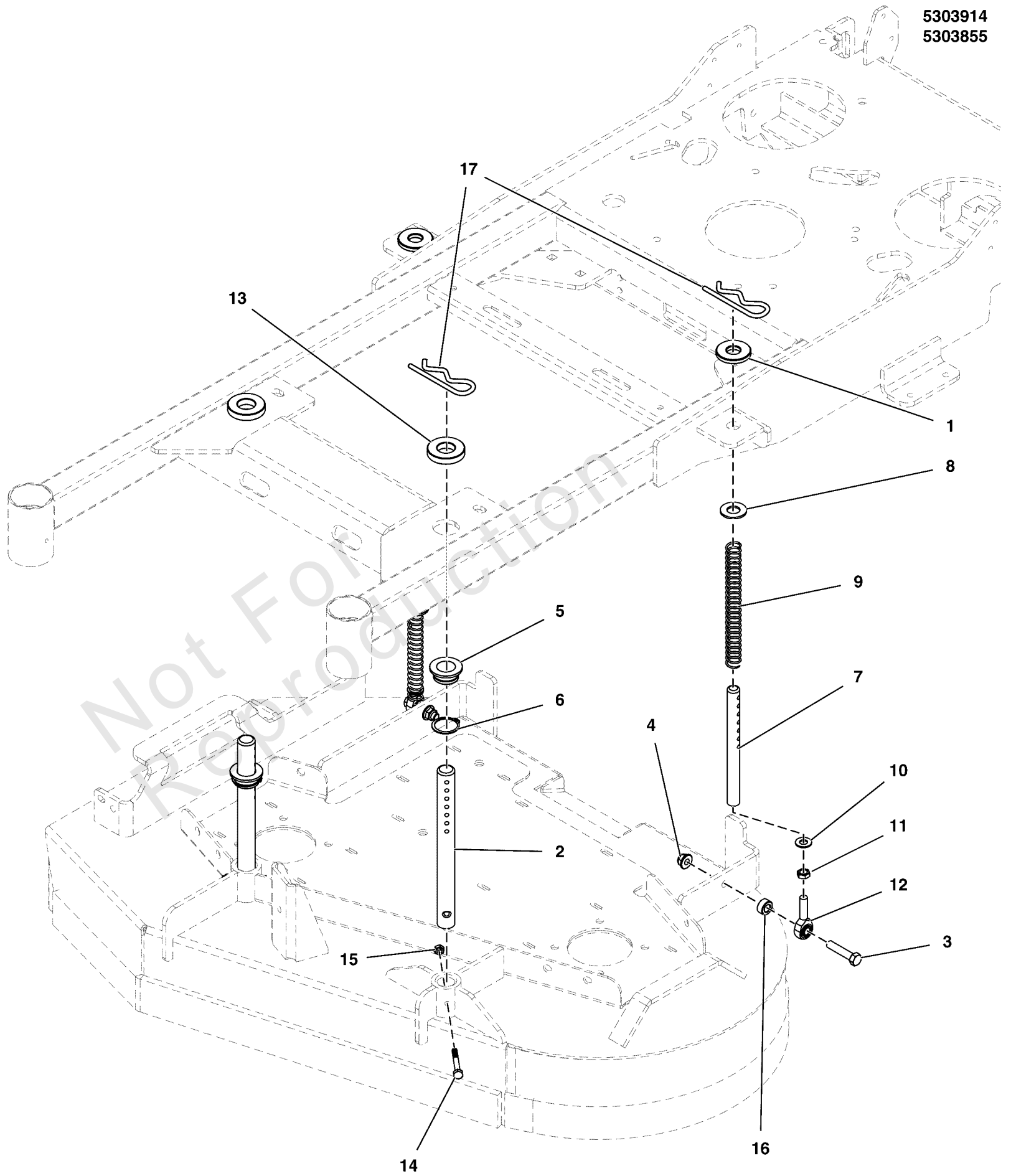

## Deck Lift Group

REF NO	PART NO	QTY	DESCRIPTION
1	5104400	2	SPACER, .688 X 1.750 X .25, CZ
2	5104346	2	SHAFT, FRONT DECK LIFT, SW25/FW25
3	5025013X14	2	BOLT, 3/8-16 X 1-3/4" GD5 CZ
4	5025394	2	NUT, 3/8-16 HEX NYLOCK FLANGE
5	5104413	2	BUSHING, FRONT DECK LIFT
6	5025614	2	SNAP RING, EXTERNAL, 1-1/4 SHAFT, BLK
7	5104345	2	SHAFT, REAR DECK LIFT, SW25/FW25
8	5025281	2	WASHER, 5/8 SAE -(36" Mower Decks Only)
9	5104374	2	SPRING, COMP, .645IDX8.00LGX.080WR, BLK E-C -(36" Mower Decks Only)
10	5025156	2	WASHER, 3/8 SAE -(36" Mower Decks Only)
11	5025309	2	NUT, 3/8-24 HEX JAM
12	5021124	2	BALL JOINT, 3/8-24 MALE
13	5104347	2	SPACER, .89 X 1.88 X .38, CZ
14	5025010X16	2	BOLT, 1/4-20 X 2", GD5
15	5025095	2	NUT, 1/4-20 HEX NYLON LOCK
16	5044933	2	SPACER, .39 X .75 X .38, PM, CZ
17	5025612	4	PIN, HAIR, .1719 X 3-1/4, 7/8 EYE, CZ

# Electrical Group

Note: Unless noted otherwise, use the standard torque specifications

Mfg. No: 5901887

26 - Wire Harness, Kawasaki Electric Start, W25  
(S/N: 2017711285 & Below)

5303856  
5303857

27 - Wire Harness, Kawasaki Manual Start, W25  
(S/N: 2017983332 & Below)

29 - Wire Harness, Kawasaki Electric Start, W25  
(S/N: 2017711286 - 2017954955)

33 - Harness, Walk Behind, Wiring, Electric Start  
(S/N: 2017954956 & Above)

34 - Wire Harness, Kawasaki Jumper

35 - Harness, Walk Behind Wiring, Manual Start  
(S/N: 2017983333 & Above)

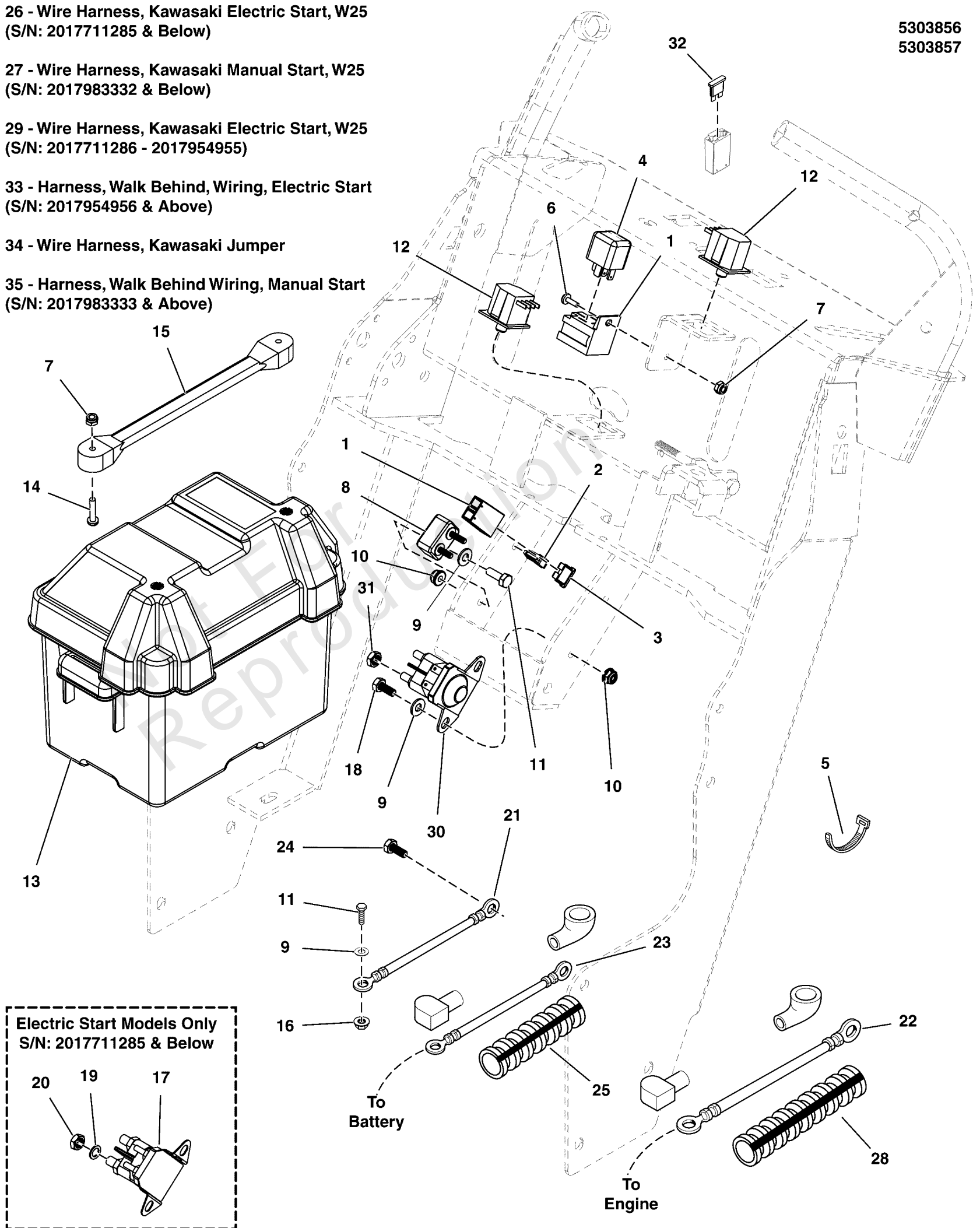

Electric Start Models Only  
S/N: 2017711285 & Below

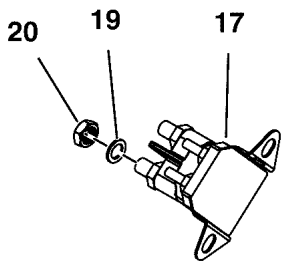



## Electrical Group

REF NO	PART NO	QTY	DESCRIPTION
1	-----	1	SEE WIRE HARNESS PART NUMBER
2	5103761	2	FIR TREE MOUNT, PACKARD -(Qty: 1 - Manual Start Models)
3	5101935	1	FUSE, ATO-15 (15 AMP)(SV)
4	5021766	1	RELAY, 12 VOLT, 40 AMP
5	5021029	8	TIE, SELF-LOCKING, 12"
6	5025179X4	1	SCREW, #10-24 X 1/2" ROUND PHILLIPS
7	5025271	3	NUT, Hex, Nylon Lock, #10-24 -(Qty: 1 - Manual Start Models)
8	1665238	1	BREAKER-CIRCUIT 12VOLT 20AMPS W/TAB -(Electric Start Models Only - S/N: 2017711285 & Below)
9	5025154	5	WASHER, 1/4 SAE -(Electric Start Models Only)
10	5025391	3	NUT, 1/4-20 Hex Nylock Flange -(Electric Start Models Only)
11	5025010X6	3	BOLT, 1/4"-20 X 3/4" GD5 YZ -(Electric Start Models Only)
12	5101280	2	SWITCH, PLUNGER, NO/NC SNAP-IN, LOW PROFILE
13	5100688	1	BATTERY BOX, W/ DRAIN HOLE -(Electric Start Models Only)
14	5025270	2	SCREW, #10-24 X 1 RS, CZ -(Electric Start Models Only)
15	5021670	1	STRAP, RUBBER -(Electric Start Models Only)
16	5025126	2	NUT, 1/4-20 HEX SERR. FLANGE -(Electric Start Models Only)
17	1724815	1	SOLENOID-4 POLE 12 VOLT DC (TROMBETTA) -(Electric Start Models Only - S/N: 2017711285 & Below)
18	-----	4	HHCS, 1/4-20 X 0.625, GR5, ZINC/CLEAR -(Electric Start Models Only)
19	5023217	2	WASHER, Light Lock, 5/16 -(Electric Start Models Only - S/N: 2017711285 & Below)
20	5023216	2	NUT, Hex Jam, 5/16-24 -(Electric Start Models Only - S/N: 2017711285 & Below)
21	5021406	1	BATTERY CABLE, NEG, 22, 1/4-5/16 -(Electric Start Models Only)
22	5023488	1	BATTERY CABLE, POS, 22, 1/4-5/16 -(Electric Start Models Only)
23	5047136	1	BATTERY CABLE, POS, 15, 1/4-5/16 -(Electric Start Models Only)
24	5025249	1	BOLT, M8-1.25 X 20 MM GD 8.8
25	5050927X10	1	WIRE LOOM, 3/8 ID X 10 IN -(Electric Start Models Only)
26	5412954	1	WIRE HARNESS, KAWI ELEC START, SW25 -(Electric Start Models Only - S/N: 2017711285 & Below)
27	5412955	1	WIRE HARNESS, KAWI MANUAL START, SW25 -(Manual Start Models Only - S/N: 2017983332 & Below)
28	5050927X16	1	WIRE LOOM, 3/8 ID X 16 IN -(Electric Start Models Only)
29	5416152	1	WIRE HARNESS, W25, KAWI ELECTRIC -(Electric Start Models Only - S/N: 2017711286 - 2017954955)
30	1755382	1	SOLENOID, STD-BRACKET, 2-SPADE -(Electric Start Models Only - S/N: 2017711286 & Above)
31	80003921	1	NUT, 1/4-20, KEPS, CONICAL WSHR, ZC/CL -(Electric Start Models Only - S/N: 2017711286 & Above)
32	5021603	1	FUSE, ATO-20 (20 AMP)(SV) -(Electric Start Models Only - S/N: 2017711286 & Above)
33	5105538	1	HARNESS, WALK BEHIND, WIRING -(Electric Start Models Only - S/N: 201954956 & Above)

# Electrical Group

Note: Unless noted otherwise, use the standard torque specifications

Mfg. No: 5901887

26 - Wire Harness, Kawasaki Electric Start, W25  
(S/N: 2017711285 & Below)

5303856  
5303857

27 - Wire Harness, Kawasaki Manual Start, W25  
(S/N: 2017983332 & Below)

29 - Wire Harness, Kawasaki Electric Start, W25  
(S/N: 2017711286 - 2017954955)

33 - Harness, Walk Behind, Wiring, Electric Start  
(S/N: 2017954956 & Above)

34 - Wire Harness, Kawasaki Jumper

35 - Harness, Walk Behind Wiring, Manual Start  
(S/N: 2017983333 & Above)

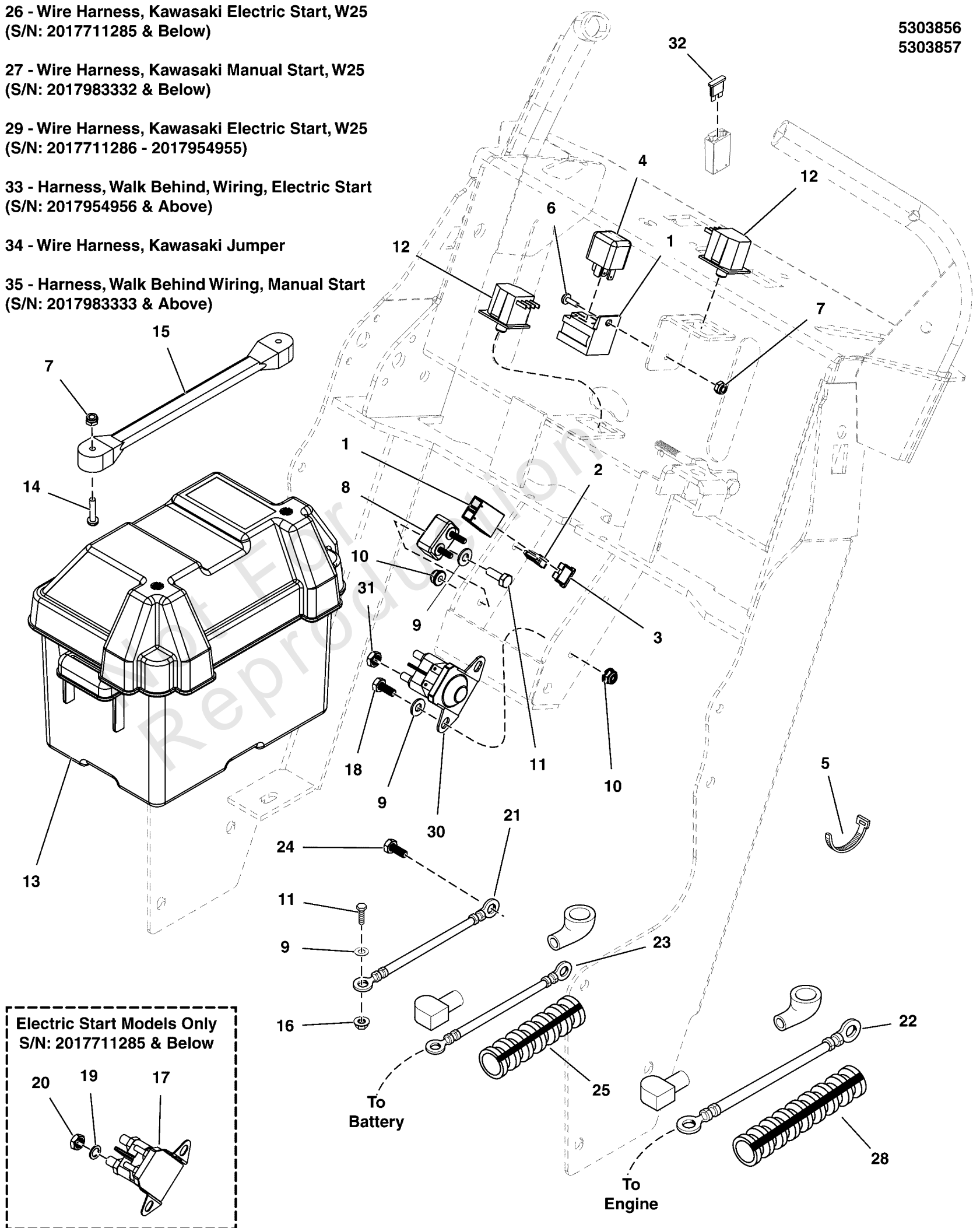

Electric Start Models Only  
S/N: 2017711285 & Below

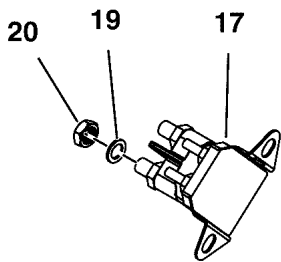

## Electrical Group

REF NO	PART NO	QTY	DESCRIPTION
34	5104811	1	WIRE HARNESS, JUMPER, KAWI -(Electric Start Models Only - S/N: 201954956 & Above)
35	5105539	1	HARNESS, MANUAL START WALK WIRING -(Manual Start Models Only - S/N: 2017983333 & Above)

Not For Reproduction

# Electrical Schematic - Charging Circuit Electric Start S/N: 2017954956 & Above

Note: Unless noted otherwise, use the standard torque specifications

Mfg. No: 5901887

## 5105538 / MAIN WIRE HARNESS - KAWASAKI FS600V ENGINES

5105538C

(If internal schematic of the switch is not shown, the image of the switch represents the back view of the connector as it is connected to the switch.)  
 \*This switch uses a "shorting" connector. When the connector is unplugged, the terminals going to the identified pole will have continuity.

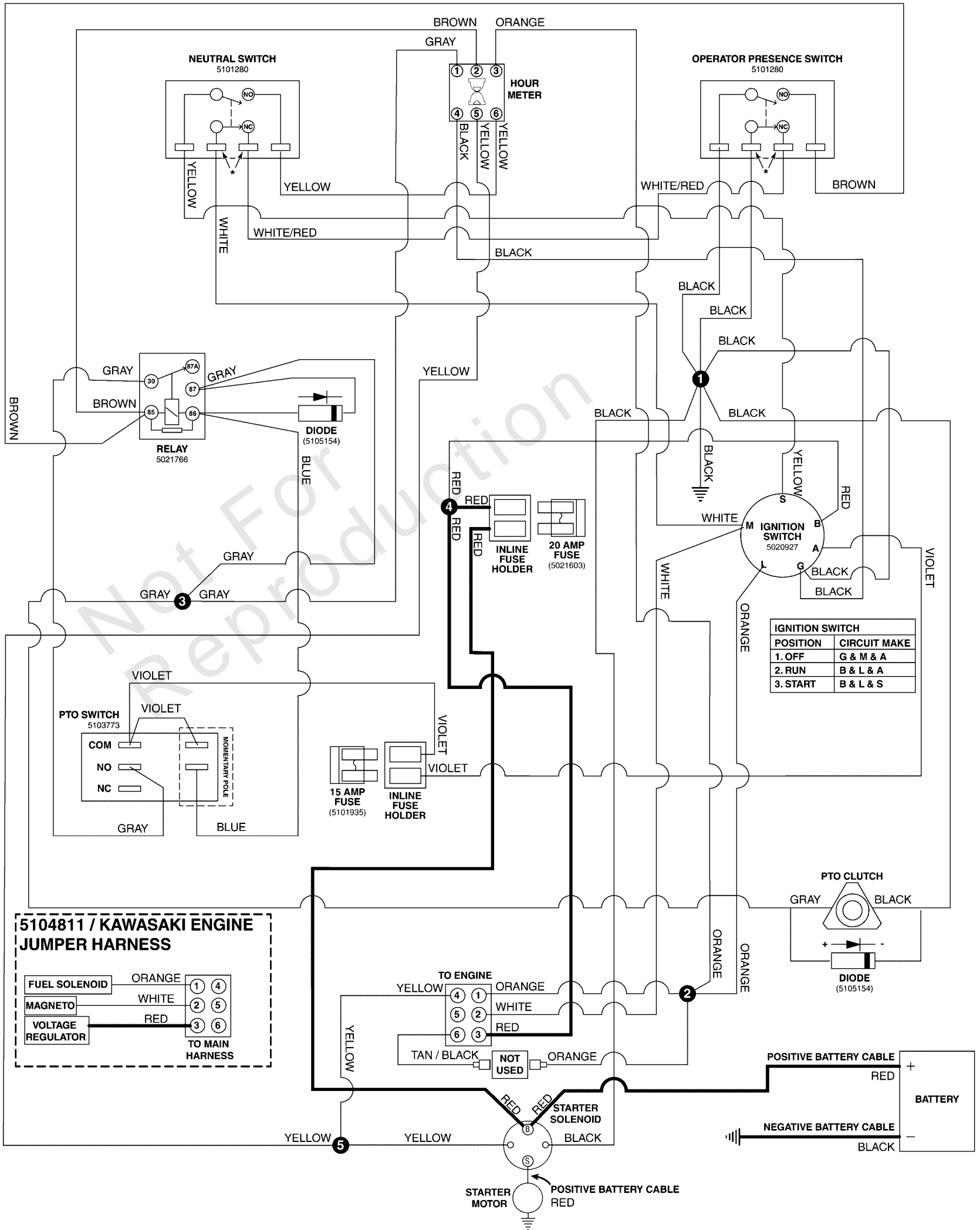

**Electrical Schematic - Charging Circuit Electric Start S/N: 2017954956 & Above**

REF NO	PART NO	QTY	DESCRIPTION
5105538	5105538	1	HARNESS, WALK BEHIND, WIRING
5104811	5104811	1	WIRE HARNESS, JUMPER, KAWI

Not For Reproduction

# Electrical Schematic - Cranking Circuit Electric Start S/N: 2017954956 & Above

Note: Unless noted otherwise, use the standard torque specifications

Mfg. No: 5901887

## 5105538 / MAIN WIRE HARNESS - KAWASAKI FS600V ENGINES

5105538C

(If internal schematic of the switch is not shown, the image of the switch represents the back view of the connector as it is connected to the switch.)  
 \*This switch uses a "shorting" connector. When the connector is unplugged, the terminals going to the identified pole will have continuity.

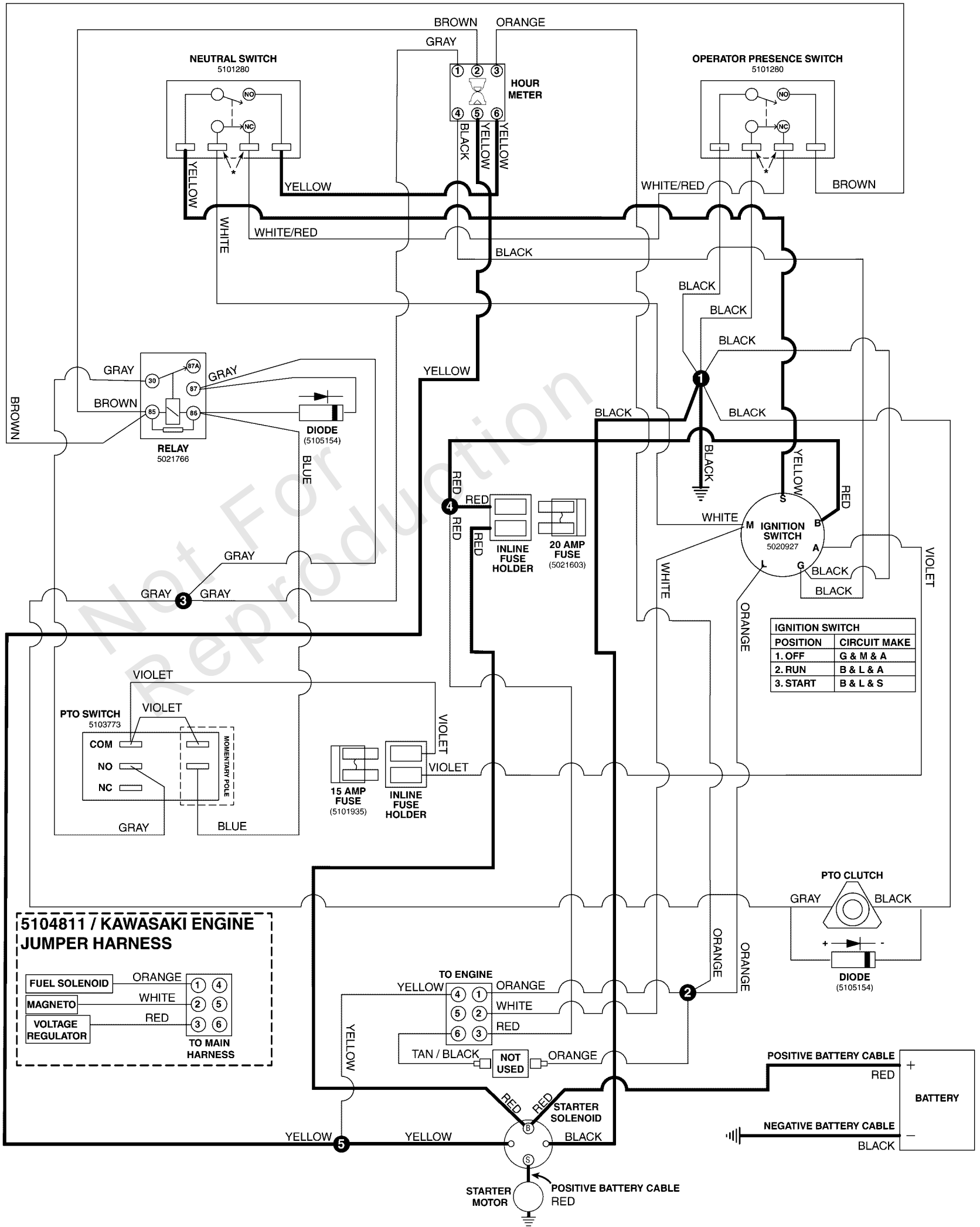

**Electrical Schematic - Cranking Circuit Electric Start S/N: 2017954956 & Above**

REF NO	PART NO	QTY	DESCRIPTION
5105538	5105538	1	HARNESS, WALK BEHIND, WIRING
5104811	5104811	1	WIRE HARNESS, JUMPER, KAWI

Not For Reproduction

# Electrical Schematic - Engine Op. Pres. Circuit Electric Start S/N: 2017954956 & Above

Note: Unless noted otherwise, use the standard torque specifications

Mfg. No: 5901887

## 5105538 / MAIN WIRE HARNESS - KAWASAKI FS600V ENGINES

5105538C

(If internal schematic of the switch is not shown, the image of the switch represents the back view of the connector as it is connected to the switch.)  
 \*This switch uses a "shorting" connector. When the connector is unplugged, the terminals going to the identified pole will have continuity.

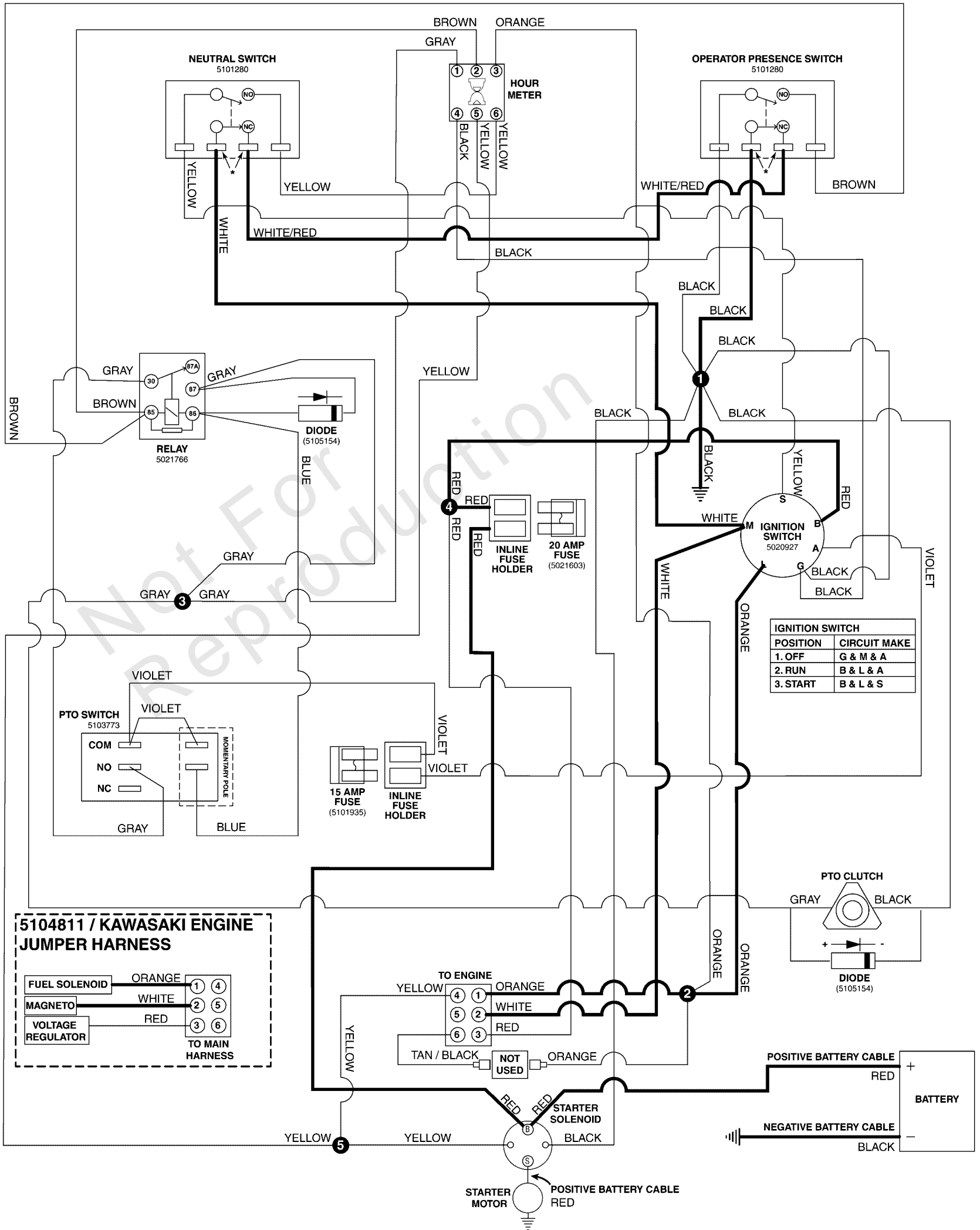



**Electrical Schematic - Engine Op. Pres. Circuit Electric Start S/N: 2017954956 & Above**

REF NO	PART NO	QTY	DESCRIPTION
5105538	5105538	1	HARNESS, WALK BEHIND, WIRING
5104811	5104811	1	WIRE HARNESS, JUMPER, KAWI

Not For Reproduction

# Electrical Schematic - PTO Op. Pres. Circuit Electric Start S/N: 2017954956 & Above

Note: Unless noted otherwise, use the standard torque specifications

Mfg. No: 5901887

## 5105538 / MAIN WIRE HARNESS - KAWASAKI FS600V ENGINES

5105538C

(If internal schematic of the switch is not shown, the image of the switch represents the back view of the connector as it is connected to the switch.)  
 \*This switch uses a "shorting" connector. When the connector is unplugged, the terminals going to the identified pole will have continuity.

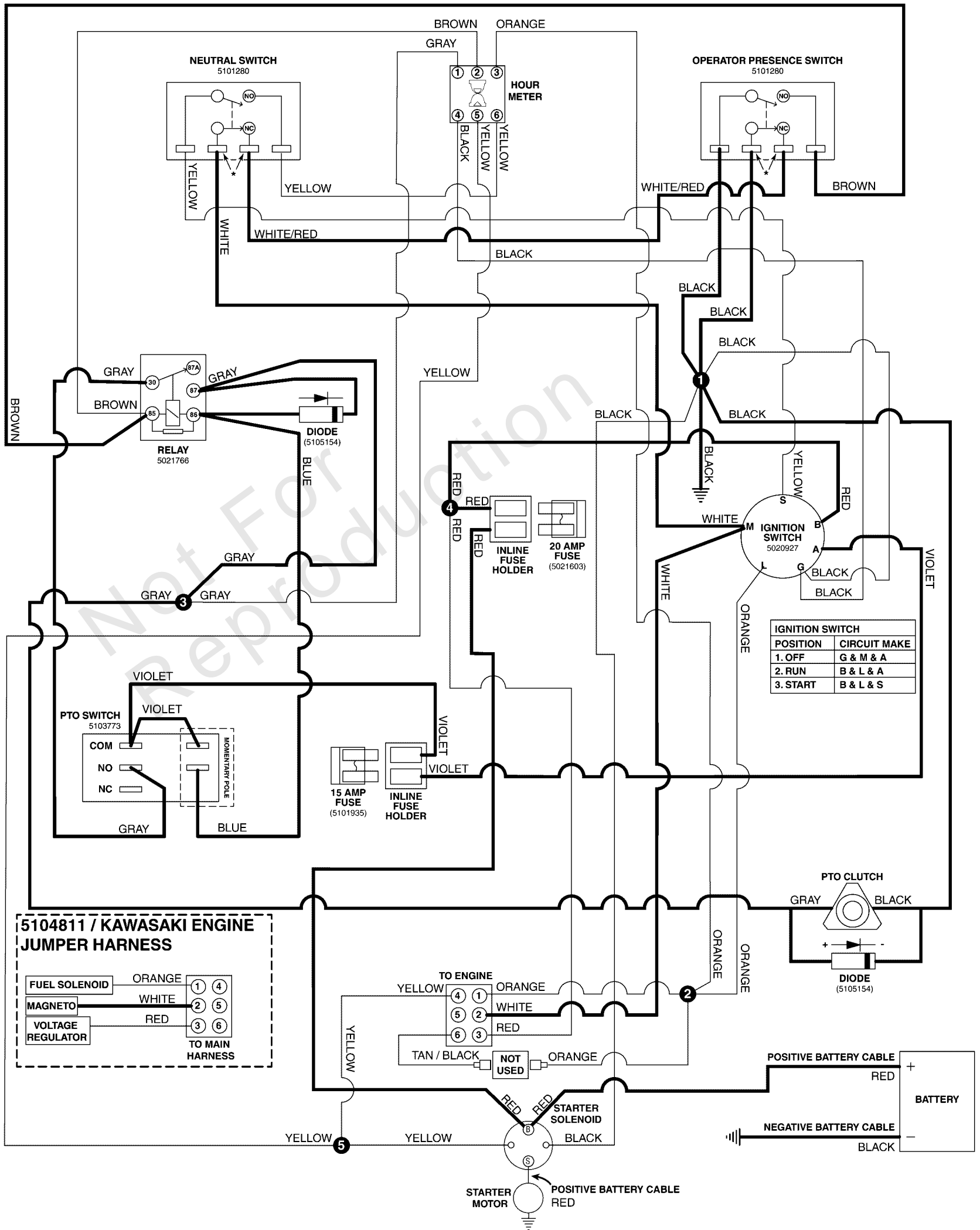

**Electrical Schematic - PTO Op. Pres. Circuit Electric Start S/N: 2017954956 & Above**

REF NO	PART NO	QTY	DESCRIPTION
5105538	5105538	1	HARNESS, WALK BEHIND, WIRING
5104811	5104811	1	WIRE HARNESS, JUMPER, KAWI

Not For Reproduction

5303925  
5303955

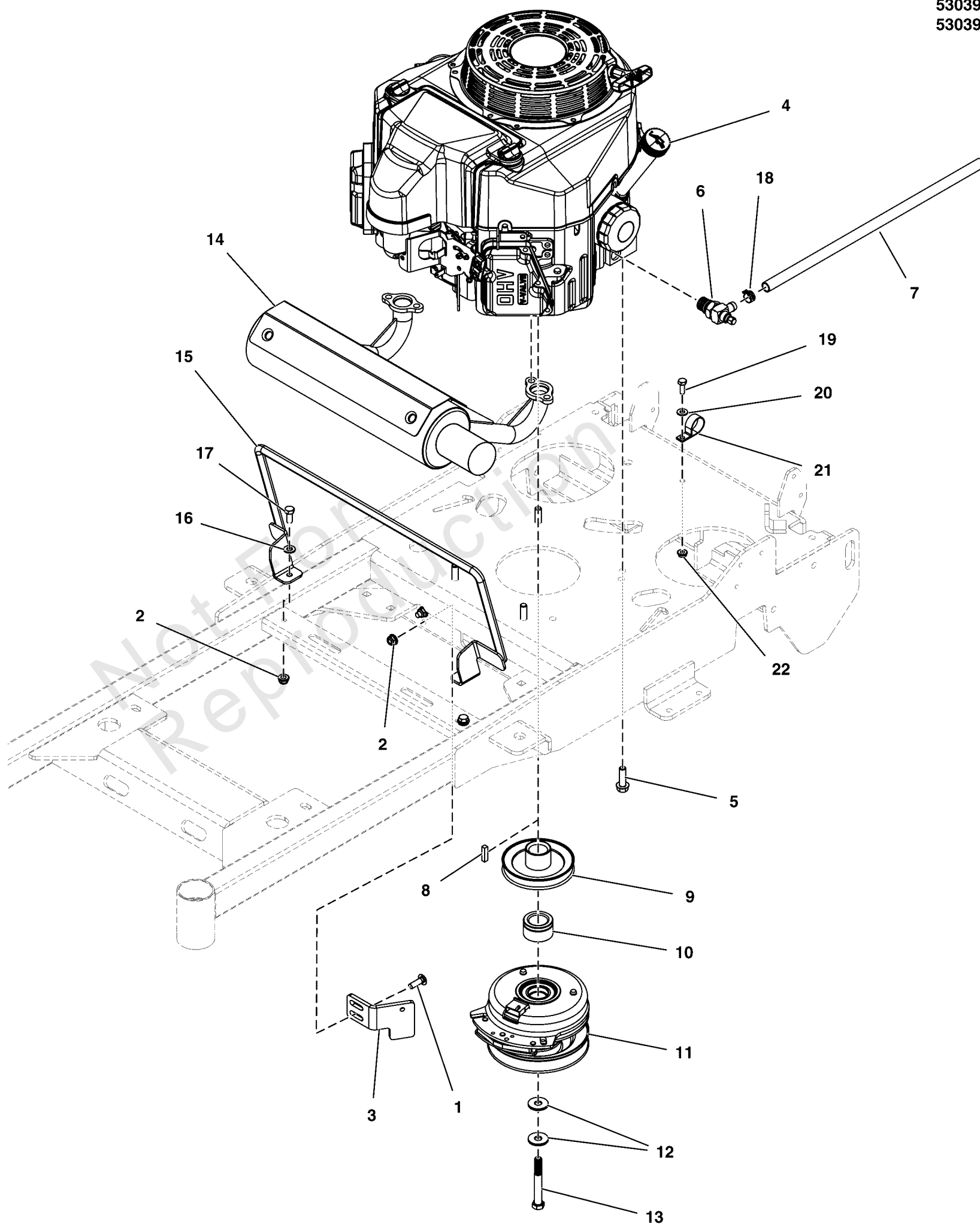

## Engine & PTO Group

REF NO	PART NO	QTY	DESCRIPTION
1	5025145X8	2	BOLT, 5/16-18 X 1, CARRIAGE
2	5025392	4	NUT, 5/16-18 HEX NYLOCK FLANGE
3	5413242A	1	PLATE, CLUTCH ANCHOR, SW25/FW25 - BLK
4	-----	1	ENGINE 15HP KAW MAN START 1-1/8"X108.8MM
4	-----	1	ENGINE, 18.5HP KAWASAKI, FS600V, ELEC ST
5	5025532	4	BOLT, 3/8-16 X 1-1/4, SF, PLT W/PATCH
6	5104567	1	VALVE, OIL DRAIN, 90 DEG. M20 X 2.5 THD
7	5104570X18	1	TUBING,CLEAR PVC,1/2"IDX5/8"OD X 18"LG
8	5050407X8	1	KEY, 1/4 SQ X 1
9	5104236	1	PULLEY, CRANKSHAFT, 1.125ID X 4.50OD, OS
10	5103892	1	SPACER, 1.13 X 1.75 X .75, CZ
11	5104440	1	CLUTCH, WARNER, 105 ft lbs - 1.13"
12	5025585	2	BELLEVILLE WASHER 1.1875 X .442 X .089
13	5102865	1	BOLT, CRANKSHAFT,7/16-20X2-3/4, GD8
14	5104539	1	MUFFLER, 15-19HP KAWI, WALKS
15	5413678A	1	WELD, GUARD, MUFFLER, W25 - BLK -(USA Models Only)
16	5025155	2	WASHER, 5/16" SAE
17	5025011X6	2	BOLT, 5/16-18 X 3/4 GD5
18	5023268	1	CLAMP, HOSE
19	5025010X6	1	BOLT, 1/4-20 X 3/4 GD5 CZ
20	5025154	1	WASHER, 1/4 SAE
21	5021500	1	CLAMP, VINYL INSULATED
22	5025126	1	NUT, 1/4-20 HEX SERR. FLANGE

0001KAWIFS

**Fits Kawasaki Engine Models Numbers:**

**FS481V**

**FS541V**

**FS600V**

**FS651V**

**FS691V**

**FS730V**

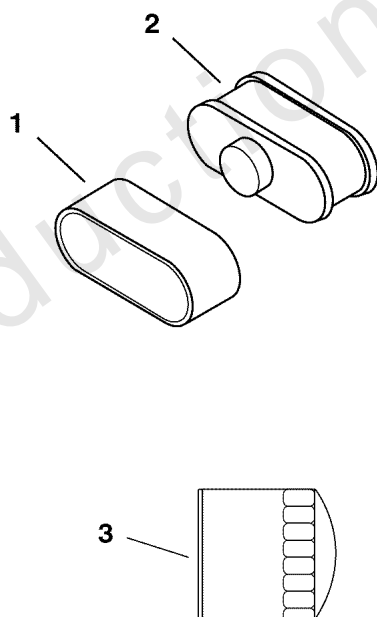

## Engine Service Parts - Kawasaki (FS481V - FS730V)

REF NO	PART NO	QTY	DESCRIPTION
1	5102278X2	1	FILTER,AIR,OUTER,KAWA FS481V THRU FS730V (11013-7046) -(SV)
2	5102278X3	1	FILTER,AIR,INNER,KAWA FS481V THRU FS730V (11013-7049) -(SV)
3	5102278X1	1	FILTER,OIL,KAWA FS,FX,FR 603 & 726CC ENG (49065-7007) -(SV)

Not For Reproduction

# Fuel Tank & Mount, Fuel Supply, and EVAP Group (No Canister)

Note: Unless noted otherwise, use the standard torque specifications

Mfg. No: 5901887

5304036  
5303858  
5303916  
5303923

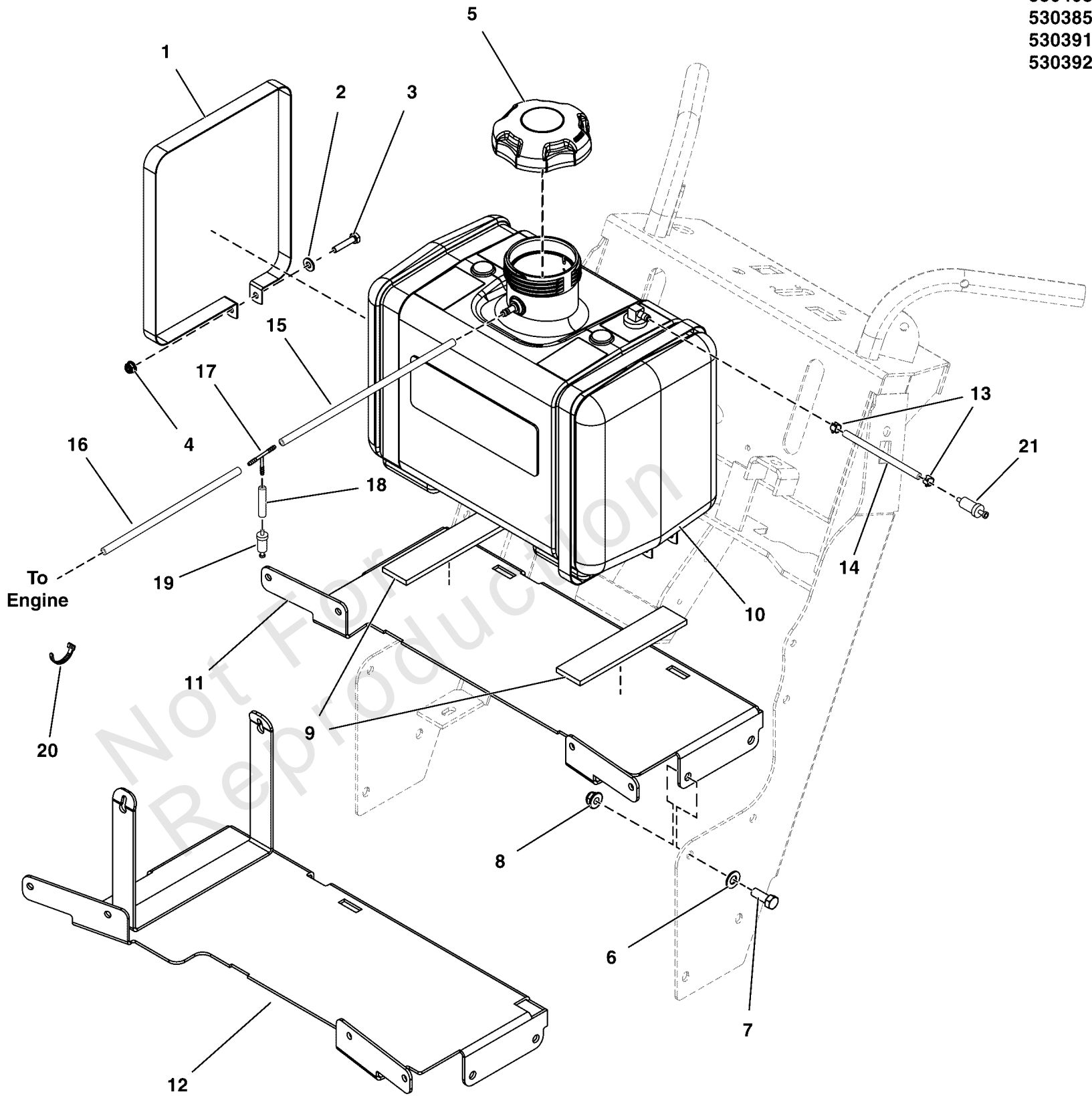



## Fuel Tank & Mount, Fuel Supply, and EVAP Group (No Canister)

REF NO	PART NO	QTY	DESCRIPTION
1	5403445A	2	STRAP, FUEL TANK
2	5025154	2	WASHER, 1/4 SAE
3	5025010X8	2	BOLT, 1/4-20 X 1" GD5 CZ
4	5025391	2	NUT, 1/4-20 HEX NYLOCK FLANGE
5	5103005	1	FUEL CAP, 3-1/2", MANAGED VENT OUT, 12"
6	5025156	4	WASHER, 3/8 SAE
7	5025013X8	4	BOLT, 3/8-16 X 1" GD5 CZ
8	5025394	4	NUT, 3/8-16 HEX NYLOCK FLANGE
9	5100810	2	PAD, RUBBER MOUNT
10	5102833	1	TANK, 4.625 GAL, W DROP TUBE/VENT
11	5412698A	1	PLATE, TANK MOUNT, SW25 MANUAL - BLK -(Manual Start Models)
12	5413733AA	1	WELD, FUEL TANK MOUNT, W25CE - BLACK -(Electric Start Models)
13	93807	2	CLAMP, HOSE, EXTERNAL, 1/2 - RED
14	5050831X12	1	HOSE, 1/4" FUEL, 12.00"
15	7700552X21P5	1	HOSE, VAPOR, 5MM ID, 21.50 LG
16	7700552X12	1	HOSE, VAPOR, 5MM ID, 12.00 LG
17	5103062	1	FITTING, 3/16" TEE, BARB TYPE, HDPE
18	7700552X3	1	HOSE, VAPOR, 5MM ID, 3.00 LG
19	80025019	1	FILTER, FUEL
20	5021030	2	TIE, SELF-LOCKING, 6"
21	5021178X3	1	FUEL FILTER -(SV)
22	5102833X1	1	GROMMET -(SV)(Grommet for fuel tank 5102833)

# Handle Bar & Instrument Control Group

Note: Unless noted otherwise, use the standard torque specifications

Mfg. No: 5901887

5304035  
5304033

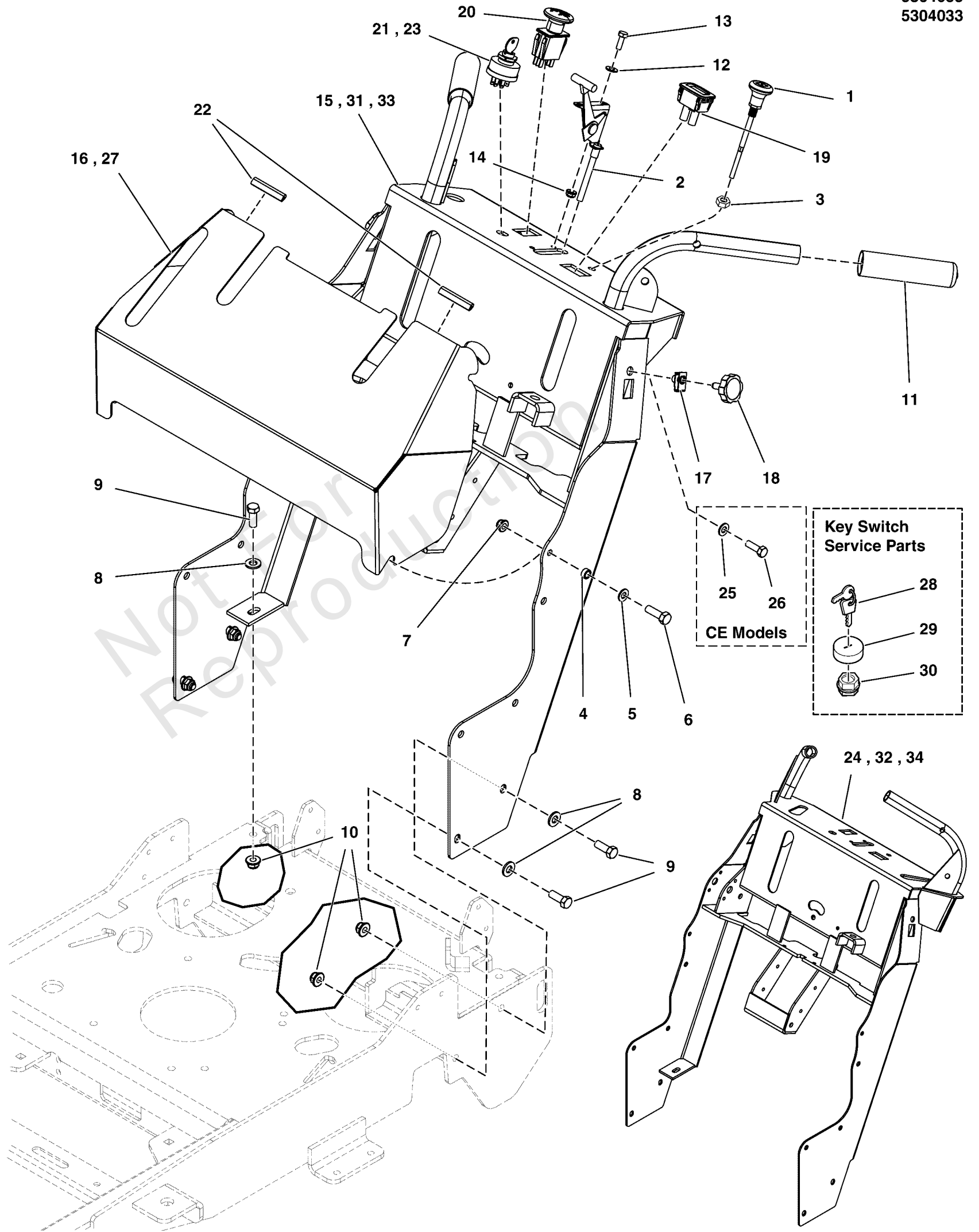

## Handle Bar & Instrument Control Group

REF NO	PART NO	QTY	DESCRIPTION
1	5047779	1	CABLE, CHOKE CONTROL, 51" (Z)
2	5104660	1	CABLE, THROTTLE, 48" DETENTED -(Kawasaki Models)
2	5047629	1	CABLE, Throttle Control, 46" -(Briggs & Stratton Models)
3	5025309	1	NUT, 3/8-24 Hex Jam
4	5102463	2	SPACER, .33 X .50 X .25, PM, CZ
5	5025155	2	WASHER, 5/16" SAE
6	5025011X8	2	BOLT, 5/16-18 X 1" GRD5 YZ
7	5025392	2	NUT, 5/16-18 HEX NYLOCK FLANGE NUT
8	5025293	6	WASHER, 3/8" GR. 9 FLAT
9	5025013X8	6	BOLT, 3/8-16 X 1" GD5 CZ
10	5025394	6	NUT, 3/8 - 16 HEX NYLOCK FLANGE
11	5104659	2	GRIP, FOAM, .940" X 4.62" X .187"
12	5025154	2	WASHER, 1/4 SAE
13	5025010X6	2	BOLT, 1/4"-20 X 3/4" GD5 YZ
14	5025391	2	NUT, 1/4-20 Hex Nylock Flange
15	5412590B	1	** WELD, HANDLE BARS, FW25 - RED -(Standard Handle Bars - S/N: 2017118253 & Below)
16	5600846	1	ASSM, HB GUARD W/DECALS, FW25 - DOM -(5413336B)
17	5022308	2	BODY CLIP, 5/16-18-7GA MATERIAL
18	5108141	2	KNOB, 5/16-18 X 1.00, ROSETTE, BLK
19	84008510	1	HOURMETER
20	5104697	1	PTO SWITCH, MOMENTARY, SMALL KNOB
21	5021842	1	SWITCH, Ignition, Complete -(Manual Start)
22	5050853X3	2	BLACK BODY MOLDING, 3" LONG
23	5020927	1	SWITCH, IGNITION, 6 POST -(Electric Start)
24	5412707B	1	** WELD, HANDLE BARS, FW25 CC - RED -(Centralized Control Handle Bars - S/N: 2017118253 & Below)
25	5025155	2	WASHER, 5/16" SAE
26	5025011X8	2	BOLT, 5/16-18 X 1" GRD5 YZ
27	5600847	1	ASSM, HB GUARD W/DECALS, FW25 - CE -(5413336B)
28	5022789	1	KEY, IGNITION MOLDED SET
29	5022790	1	COVER, PLASTIC, SNAP ON
30	5022791	1	PLASTIC NUT
31	5413922B	1	** WELD, HANDLE BARS, FW25 - RED -(Standard Handle Bars - S/N: 2017118254 - 2017170234)
32	5413923B	1	** WELD, HANDLE BARS, FW25 CC - RED -(Centralized Control Handle Bars - S/N: 2017118254 - 2017170234)
33	5414456B	1	** WELD, HANDLE BARS, W25 - STND - RED -(Standard Handle Bars - S/N: 2017170235 & Above)
34	5414457B	1	** WELD, HANDLE BARS, W25 - CC - RED -(Centralized Control Handle Bars - S/N: 2017170235 & Above)

### Footnotes:

\*\* If replacing order all appropriate decals for handle bar.

# Hydraulic Group

Note: Unless noted otherwise, use the standard torque specifications

Mfg. No: 5901887

5303862

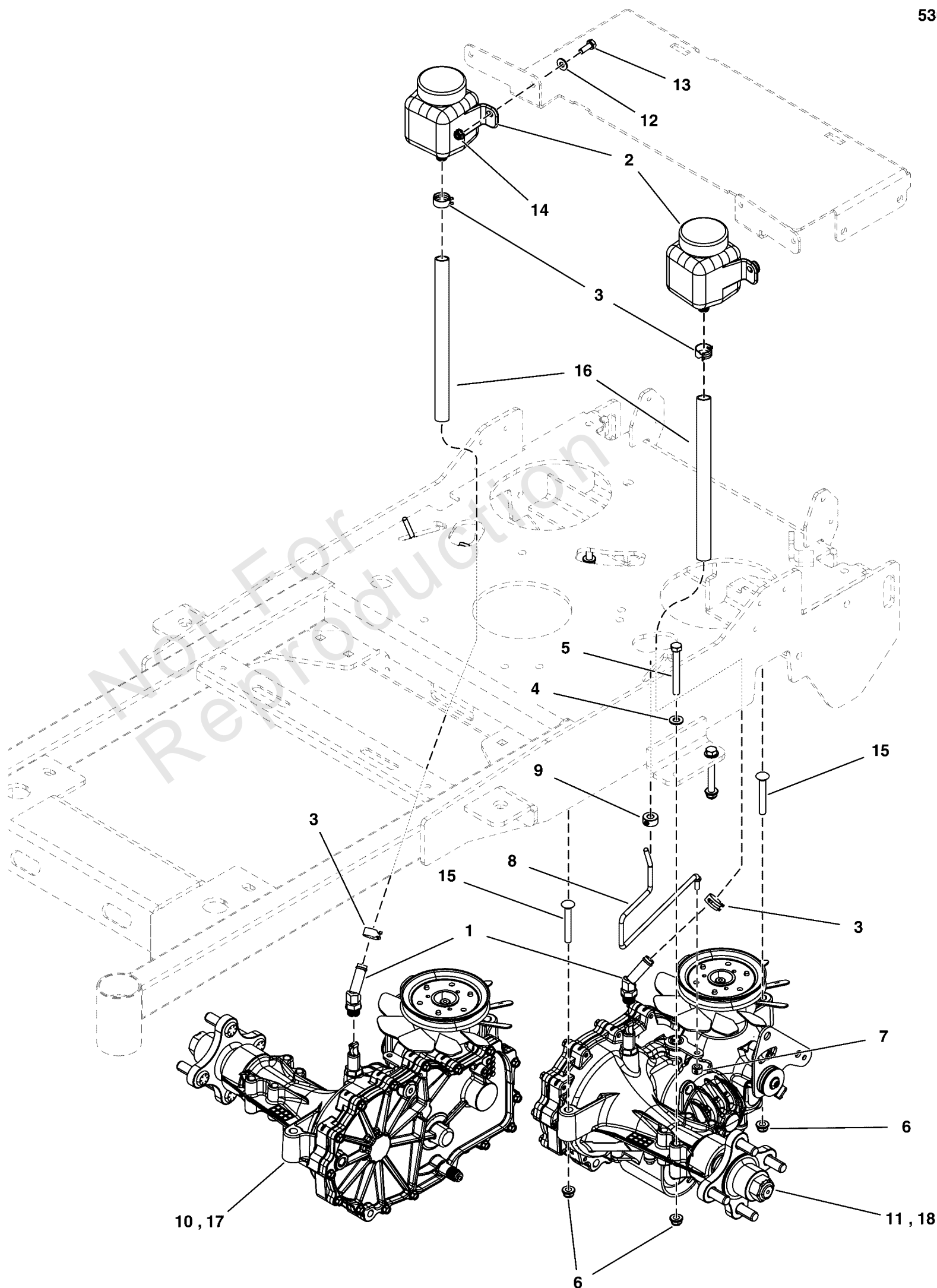

## Hydraulic Group

REF NO	PART NO	QTY	DESCRIPTION
1	5102054	2	FITTING, 1/2 HOSE - 9/16 O-RING, 45 ELB
2	5100473	2	HYDRO RES. #71328, 350 ml
3	5025474	4	CLAMP, HOSE, .75 FREE DIA.
4	5025155	4	WASHER, 5/16" SAE
5	5025011X22	4	BOLT, 5/16-18 X 2-3/4 GD5 CZ
6	5025392	8	NUT, 5/16-18 HEX NYLOCK FLANGE
7	5022481	2	COLLAR, 1/4 SET
8	5104532	2	ROD, HYDRO RELEASE, W25
9	5020047	2	COLLAR, 5/16 SET
10	5104472	1	TRANSAXLE, ZT3100, RH, ZJ-KMFE-3L5C-1PLX -(S/N: 2017170234 & Below)
11	5104471	1	TRANSAXLE, ZT3100, LH, ZJ-GMFE-3L5B-1PLX -(S/N: 2017170234 & Below)
12	5025154	4	WASHER, 1/4 SAE
13	5025010X6	4	BOLT, 1/4-20 X 3/4 GD5 CZ
14	5025391	4	NUT, 1/4-20 HEX NYLOCK FLANGE
15	5025145X20	4	BOLT, 5/16-18 X 2-1/2, CARRIAGE, GD5, CZ
16	5050857X7P5	2	HOSE, 1/2" PUSH-ON, 7.50"
17	5106330	1	TRANSAXLE, ZT3100, RH, ZL-KMFE-3L5C-1PXE -(S/N: 2017170235 to 40015467047)
17	5109241	1	TRANSAXLE, ZT-3100, RH,ZL-KMFE-SL5C-1PXX -(S/N: 40015467048 to above)
18	5106331	1	TRANSAXLE, ZT3100, LH, ZL-GMFE-3L5B-1PXE -(S/N: 2017170235 to 40015467047)
18	5109240	1	TRANSAXLE, ZT-3100, LH,ZL-GMFE-SL5B-1PXX -(S/N: 40015467048 to above)

# Main Frame & Front Caster Group

Note: Unless noted otherwise, use the standard torque specifications

Mfg. No: 5901887

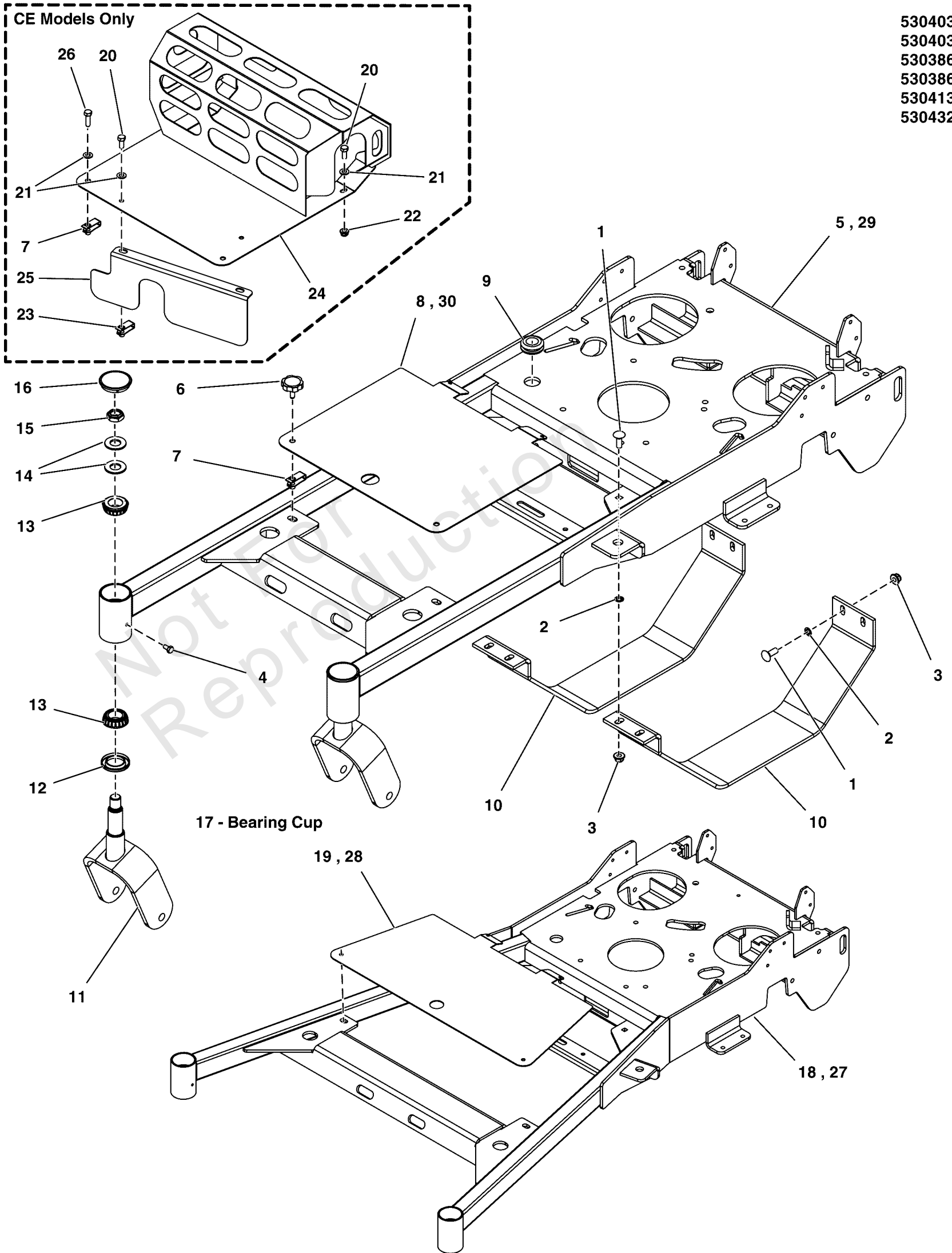

- 5304031
- 5304032
- 5303863
- 5303864
- 5304139
- 5304321

## Main Frame & Front Caster Group

REF NO	PART NO	QTY	DESCRIPTION
1	80004497	8	BOLT,3/8-16X1.000,RND HD CRRG,ZINC/CLEAR
2	5025472	8	3/8 PUSHNUT BOLT RETAINER
3	5025394	8	NUT, 3/8 - 16 HEX NYLOCK FLANGE
4	5025457	2	BOLT, 1/4-28 X 1/2, GD5 YZ
5	5412769B	1	WELD, MAIN FRAME, FW25 - 36 - RED -(36" Models - S/N: 2017555756 & Below)
6	5108141	2	KNOB, 5/16-18 X 1.00, ROSETTE, BLK
7	5025452	2	BODY CLIP, 5/16-18 -1/4 MATERIAL
8	5413166B	1	GUARD, WALK, FRONT FRAME, 36 - RED -(36" Models - S/N: 2017555756 & Below)
9	5103944	1	GROMMET, 7/8"ID, 1/4" THICK STK
10	5413033A	2	PLATE, TRANS GUARD SW25 - BLK
11	5407308B	2	WELD, CASTER YOKE, SNP DD - RED
12	5021072	2	SEAL, GREASE
13	5020884	4	BEARING, TAPERED ROLLER, 1"
14	5025449	4	WASHER, BELLEVILLE - 1.500 X .755
15	5025448	2	NUT, 3/4-16, HEX JAM NYLON LOCK
16	5109845	2	CAP, GREASE, LOW PROFILE
17	5020884	4	BEARING, TAPERED ROLLER, 1" -(SV)
18	5412585B	1	WELD, MAIN FRAME, FW25 - 48 - RED -(48" Models - S/N: 2017170234 & Below)
19	5413179B	1	PLATE, FRONT FRAME GUARD FW25 48 - RED -(48" Models - S/N: 2017170234 & Below)
20	5025011X8	2	BOLT, 5/16-18 X 1" GRD5 YZ -(CE Models Only)
21	5025155	6	WASHER, 5/16" SAE -(CE Models Only)
22	5025392	1	NUT, 5/16-18 HEX NYLOCK FLANGE NUT -(CE Models Only)
23	5022308	2	BODY CLIP, 5/16-18-7GA MATERIAL -(CE Models Only)
24	5413729B	1	WELD, MUFFLER GUARD, FW2536CE - RED -(CE Models Only - S/N: 2017746073 & Below)
24	5416154B	1	WELD, MUFFLER GUARD, FW25 36CE - RED -(CE Models Only - S/N: 2017746074 & Above)
25	5413742B	1	PLATE, FRONT DECK GUARD,FW2536RDCE-RED -(CE Models Only - S/N: 2017746073 & Below)
25	5416155B	1	PLATE, DECK GUARD, FRONT, FW25 36CE - RED -(CE Models Only - S/N: 2017746074 & Above)
26	5025011X8	2	BOLT, 5/16-18 X 1" GRD5 YZ -(CE Models Only)
27	5422130B	1	WELD, MAIN FRAME, W25, 48/52 - RED -(48" Models - S/N: 2017170235 & Above; 52" Models - S/N: All)
28	5414286B	1	PLATE, GUARD, FRONT FRAME, W25 48/52 - RED -(48" Models - S/N: 2017170235 & Above; 52" Models - S/N: All)
29	5422140B	1	WELD, MAIN FRAME, W25, 36 - RED -(36" Models - S/N: 2017555757 & Above)
30	5415716B	1	PLATE, FRAME GUARD, W25 36 - RED -(36" Models - S/N: 2017555757 & Above)

# Motion Control Group - Lower

Note: Unless noted otherwise, use the standard torque specifications

Mfg. No: 5901887

5304037L  
5303865L

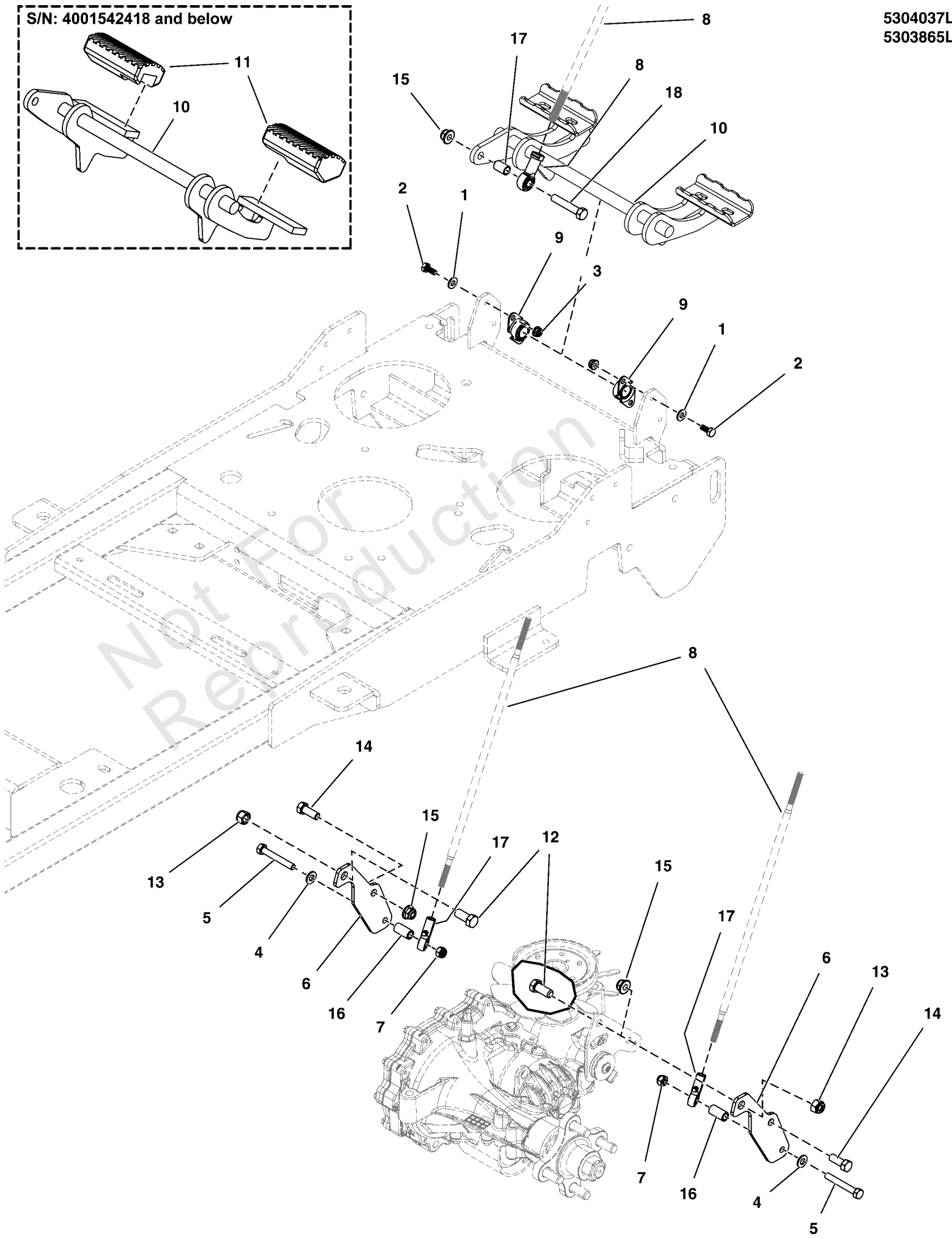
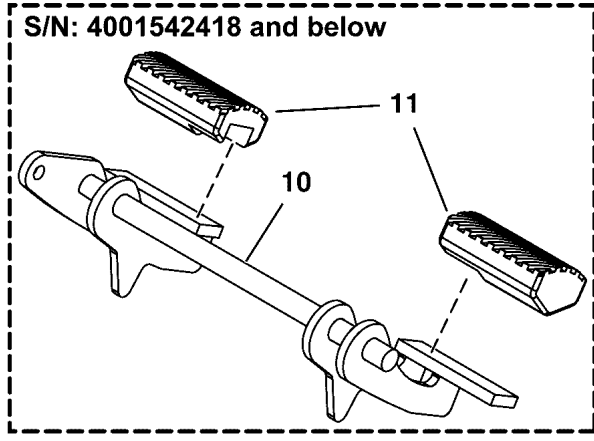



## Motion Control Group - Lower

REF NO	PART NO	QTY	DESCRIPTION
1	5025154	4	WASHER, 1/4 SAE
2	-----	4	HHCS, 1/4-20 X 0.625, GR5, ZINC/CLEAR
3	5025391	4	NUT, 1/4-20 Hex Nylock Flange
4	5025155	2	WASHER, 5/16" SAE
5	5025011X18	2	BOLT, 5/16-18 X 2-1/4" GD5 YZ
6	84007883	2	MOUNT
7	5025057	2	NUT, Hex, Nylon Locking, 5/16-18
8	-----	1	SEE MOTION CONTROL UPPER GROUP
9	5104270	2	BEARING, 5/8" FLANGED, PLASTIC BALL
10	5412284AA	1	WELD, FOOT PEDAL - BLK -(Refer to Note: *)
11	5104262	2	PEDAL, Rubber -(S/N: 4001542418 and below)
12	5025015X6	2	BOLT, 7/16-14 X 3/4, GD 5 YZ
13	5025044	2	NUT, 7/16-14 HEX TOP LOCK
14	5025013X8	2	BOLT, 3/8-16 X 1" GD5 CZ
15	5025394	3	NUT, 3/8 - 16 HEX NYLOCK FLANGE
16	84008514	2	SPACER (.325 X .496 X 1.000)
17	5047199	1	SPACER, .38 x .50 x .75
18	5025013X16	1	BOLT, 3/8-16 X 2, GD5, CZ

---

**Footnotes:**

Note: \*All replacement foot pedal weldments will have welded pedals.

# Motion Control Group - Spring Assemblies

Note: Unless noted otherwise, use the standard torque specifications

Mfg. No: 5901887

5304037SA  
5303865SA

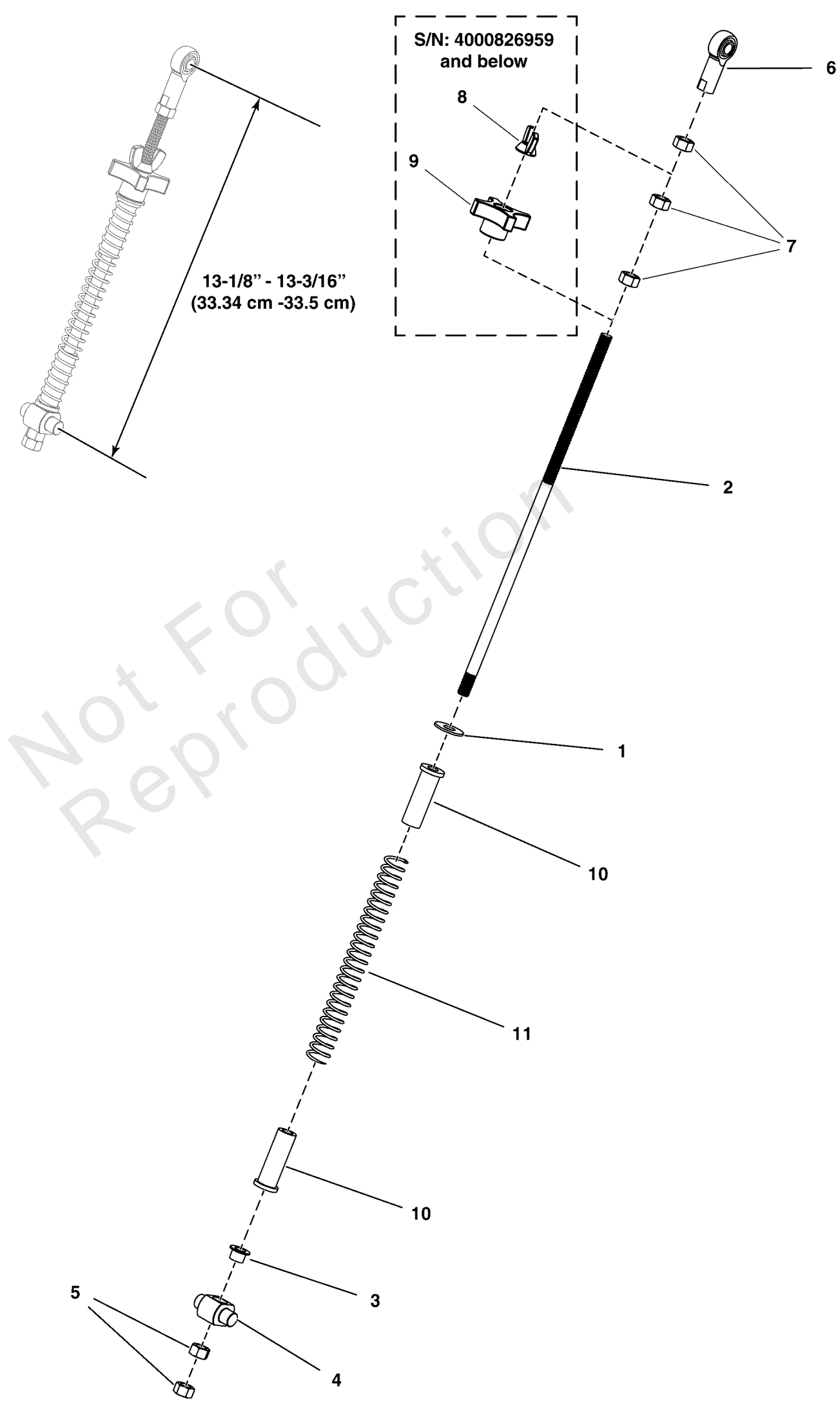

Not For  
Reproduction

## Motion Control Group - Spring Assemblies

REF NO	PART NO	QTY	DESCRIPTION
1	5025401	2	WASHER, 3/8 USS
2	5104229	2	ROD, CONTROL SYSTEM, WALK
3	5102773	2	BUSHING, .38ID X .47 OD X .38L, FL
4	5103022	2	TRUNION, 1/2" POSTS, STAINLESS
5	5025034	4	NUT, 3/8-16 HEX
6	5021683	2	BALL JOINT, 3/8-24 FEMALE
7	5025035	6	NUT, 3/8-24 HEX -(Qty: 2 - S/N: 4000826959 and below)
8	5025608	2	WING NUT, 3/8-24, CZ -(S/N: 4000826959 and below)
9	5104174	2	KNOB, 4 ARM, 3/8-24 -(S/N: 4000826959 and below)
10	5104375	4	FLANGED BUSHING, 3/8IDX.63ODX.8125FL
11	5104374	2	SPRING,COMP,.645IDX8.00LGX.080WR,BLK E-C

Not For Reproduction

# Motion Control Group - Upper (Standard Controls)

Note: Unless noted otherwise, use the standard torque specifications

Mfg. No: 5901887

5303865U

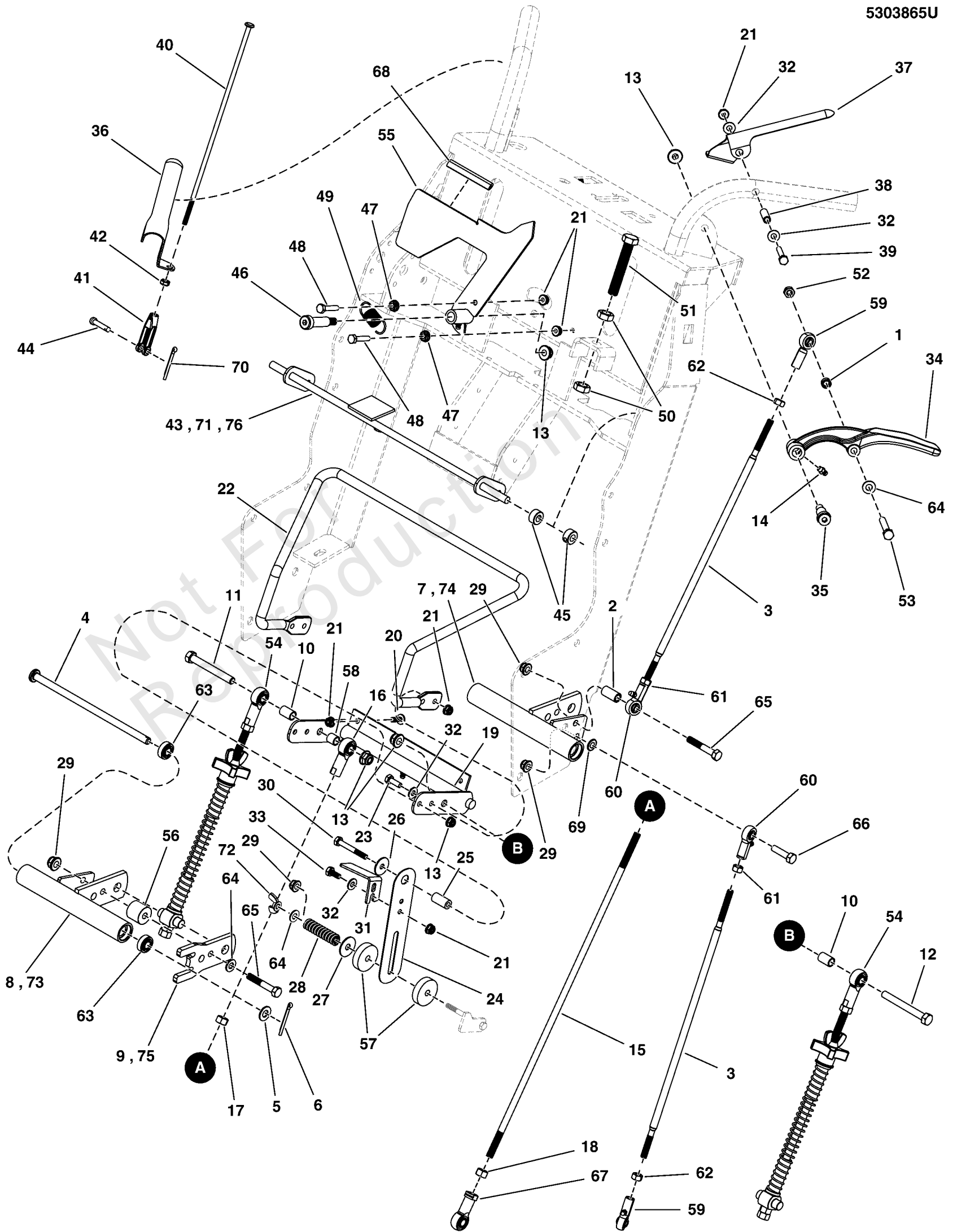

## Motion Control Group - Upper (Standard Controls)

REF NO	PART NO	QTY	DESCRIPTION
1	5102463	2	SPACER, .33 X .50 X .25, PM, CZ
2	84008514	2	SPACER (.325 X .496 X 1.000)
3	5104159	4	ROD, 5/16-24 X 15.48, LH-RH, CZ
4	5104328	2	ROD, 3/8 X 8.49, HEADED
5	5025156	2	WASHER, 3/8 SAE
6	5025203X10	2	PIN, COTTER, 1/8 X 1-1/4
7	5412616A	1	WELD, CENTER PIVOT HUB, LH - WALK - BLK -(S/N: 2017170234 & Below)
8	5412617A	1	WELD, CENTER PIVOT HUB, RH - WALK - BLK -(S/N: 2017170234 & Below)
9	5411633A	2	TAB, CONTROL PIVOT - BLK -(S/N: 2017170234 & Below)
10	5047199	2	SPACER, .38 X .50 X .75
11	5025013X24	1	BOLT, 3/8-16 X 3" GD5 CZ
12	5025013X16	1	BOLT, 3/8-16 X 2, GD5, CZ
13	5025394	6	NUT, 3/8-16 HEX NYLOCK FLANGE
14	5020095	2	GREASE FITTING, 1/4-28 STRAIGHT
15	5104164	1	ROD, 3/8-24, 19.00, LH-RH CZ
16	5021683	1	BALL JOINT, 3/8-24 FEMALE
17	5025035	1	NUT, 3/8-24 HEX
18	5025317	1	NUT, 3/8-24 HEX, LH
19	5412891A	1	NLA - WELD, SPEED CONTROL, SW35 - BLK
20	1960715	2	SCREW-TRUSS HD TORX DR 1/4-20X0.750 T27
21	5025391	12	NUT, 1/4-20 HEX NYLOCK FLANGE
22	5104216A	1	BAR, SPEED CONTROL - BLK
23	5025010X6	3	BOLT, 1/4-20 X 3/4 GD5 CZ
24	5409272	1	PLATE, FRICTION CONTROL, SS
25	5101274	1	SPACER, .26 X .50 X 1.00
26	5025288	1	WASHER, 1/4 FENDER
27	5025164	1	WASHER, 5/16 FENDER
28	5104221	1	SPRING, COMP, .40 X .60 X 2.25, BLACK
29	5025392	6	NUT, 5/16-18 HEX NYLOCK FLANGE -(Qty: 7 - S/N: 2017118253 & Below)
30	5025010X16	1	BOLT, 1/4-20 X 2", GD5
31	5412363A	1	BRACKET, SWITCH ENGAGEMENT - BLK
32	5025154	9	WASHER, 1/4 SAE
33	-----	2	HHCS, 1/4-20 X 0.625, GR5, ZINC/CLEAR
34	5102556A	2	HANDLE, REVERSING - BLK
35	5109888	2	BOLT, 3/8-16 X 1/2, 1.00 SHOULDER, CZ
36	5104201A	1	NLA - FLAP, OPS - BLK
37	5104202A	1	NLA - FLAP, OPS - BLK
38	5101215	2	SPACER, .26 X .38 X 1.25, CZ
39	5025010X14	2	BOLT, 1/4-20 X 1-3/4 GD5 CZ
40	5101242	2	ROD, OPC LINK, SNP PRO WB
41	84007748	2	CLEVIS
42	7090095	2	HN, 1/4F GR5 YZ
43	5412020A	1	WELD, OPC ROD, WALK - BLK -(S/N: 2017118253 & Below)
44	5025212X7	2	PIN, CLEVIS, 1/4 X 7/8, PLATED
45	5010546	2	COLLAR, 3/8 SET
46	5025220	1	BOLT-3/8-16 x 1-1/2, 1/2 SHOULDER
47	5025126	2	NUT, 1/4-20 HEX SERR. FLANGE
48	5025010X10	2	BOLT, 1/4-20 X 1-1/4 GD5 CZ

# Motion Control Group - Upper (Standard Controls)

Note: Unless noted otherwise, use the standard torque specifications

Mfg. No: 5901887

5303865U

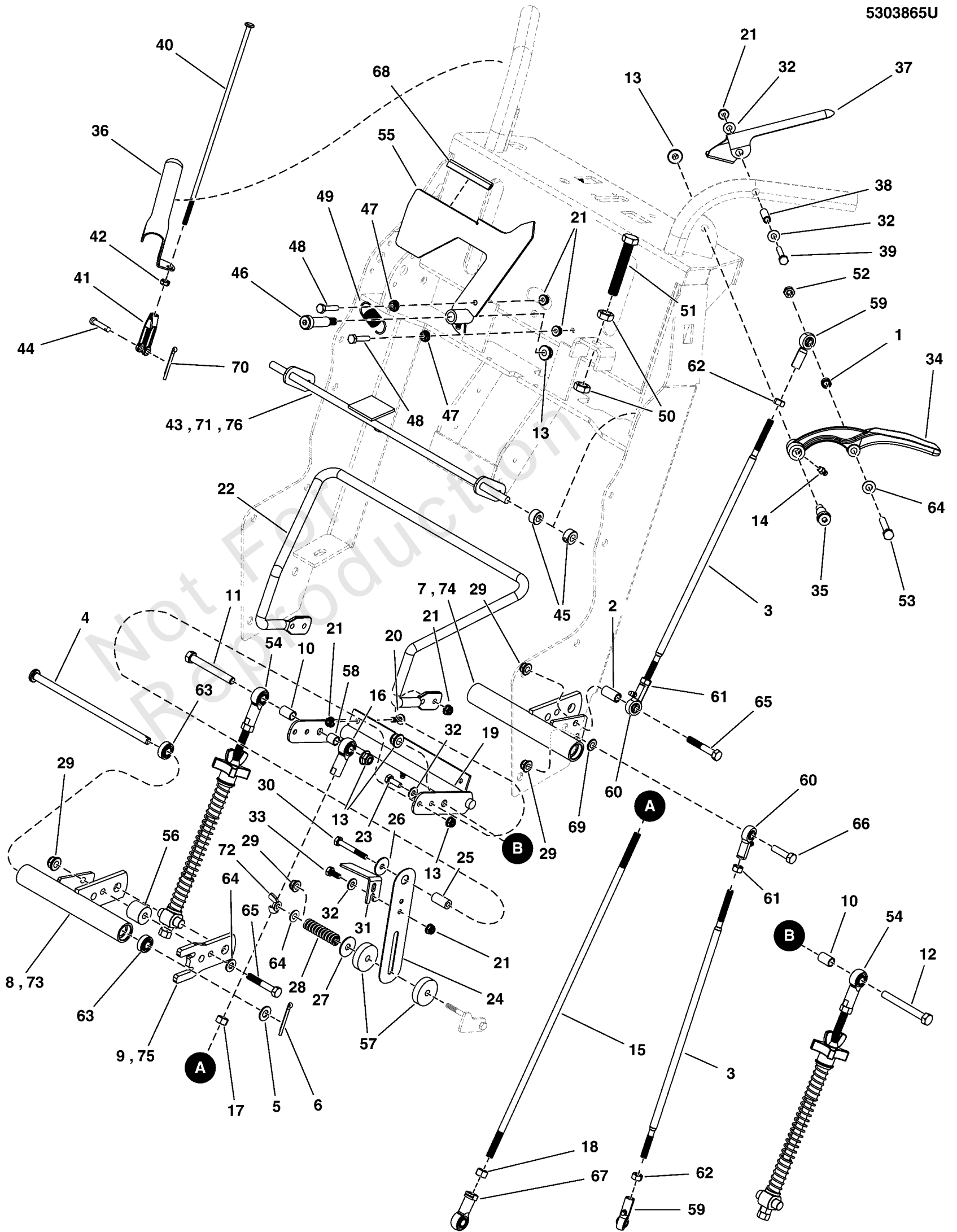

## Motion Control Group - Upper (Standard Controls)

REF NO	PART NO	QTY	DESCRIPTION
49	5105337	1	SPRING, EXT, 0.525 X 0.058 X 2.250 SS
50	5025089	2	NUT, 1/2-20 HEX JAM
51	5025426	1	BOLT, 1/2-20 X 2-1/2, FLT
52	5025057	2	NUT, 5/16-18 HEX NYLON LOCK
53	5025011X18	2	BOLT, 5/16-18 X 2-1/4 GD5 CZ
54	-----	1	SEE MOTION CONTROL GROUP - SPRING ASSEMBLIES
55	5413693A	1	WELD, SPEED INDICATOR, W25 - BLK
56	5104351	2	SPACER, .33 X 1.00 X .88, CZ
57	5104176	2	PAD, T-712 FRICTION MATERIAL
58	5101640	1	SPACER, .38 X .50 X .50
59	5104493	4	BALL JOINT 5/16-24 RH FEMALE BRONZE RACE
60	5104494	4	BALL JOINT 5/16-24 LH FEMALE BRONZE RACE
61	5023212	4	NUT, 5/16-24 HEX, LH
62	5025033	4	NUT, 5/16-24 HEX
63	5102003	4	BEARING, .375" ID X .875" OD X .341" THK
64	5025155	3	WASHER, 5/16" SAE -(Qty: 2 - S/N: 2017118253 & Below)
65	5025011X16	4	BOLT, 5/16-18 X 2 GD5 CZ
66	5025011X10	2	BOLT, 5/16-18 X 1-1/4 GD5 CZ
67	5022392	1	BALL JOINT, 3/8-24 FEMALE, LH
68	5104568	1	U-CHANNEL, RPVC #6236 X 4"
69	5025292	2	WAHSER, 5/16 F436 FLAT
70	80002736	2	PIN, 3/32 X 0.750, COT, ZINC/CLEAR
71	5413926A	1	WELD, OPC ROD, WALK - BLK -(S/N: 2017118254 - 2017170234)
72	703429	1	NUT, Wing, 5/16-18 -(S/N: 2017118254 & Above)
73	5414181A	1	WELD, W25 CONTROL PIVOT, RH - BLK -(S/N: 2017170235 & Above)
74	5414182A	1	WELD, W25 CONTROL PIVOT, LH - BLK -(S/N: 2017170235 & Above)
75	5414411A	2	TAB, PIVOT, W35 - BLK -(S/N: 2017170235 & Above)
76	5414516A	1	WELD, OPC ROD, WALKBEHIND - BLK -(S/N: 2017170235 & Above)

# Parking Brake Group

Note: Unless noted otherwise, use the standard torque specifications

Mfg. No: 5901887

5303866

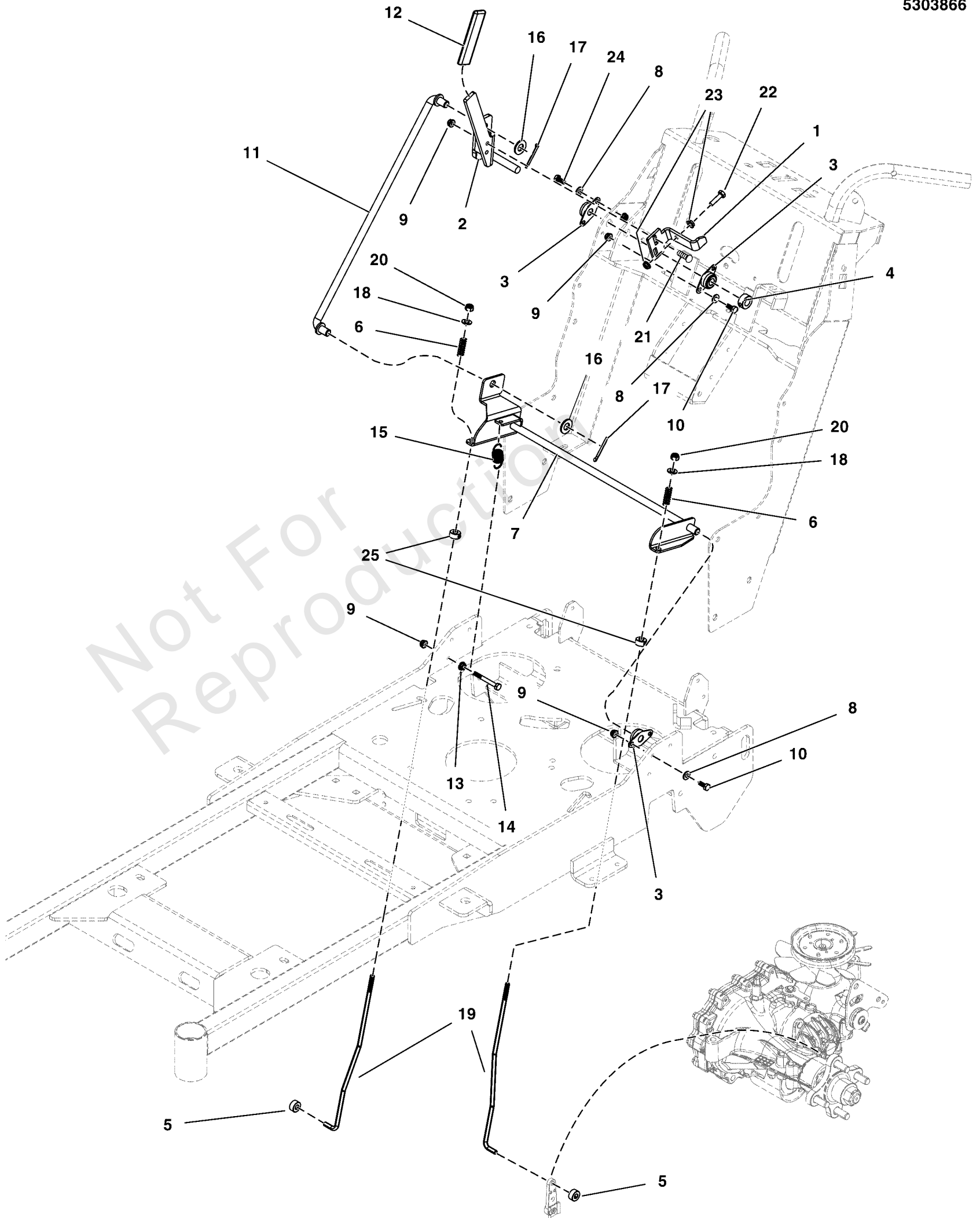



## Parking Brake Group

REF NO	PART NO	QTY	DESCRIPTION
1	5413511A	1	PLATE, NEUTRAL LOCKOUT, SW25 - BLK
2	5412860A	1	WELD, PARKING BRAKE HANDLE - BLK
3	5101123	4	BEARING, 1/2 FLANGED, PLASTIC BALL
4	5010580	1	COLLAR, 1/2 SET
5	5020047	2	COLLAR, 5/16 SET
6	5020637	2	SPRING-COMP, .375IDX2.75LGX.054WR, SS
7	5412846A	1	WELD, PARKING BRAKE, SW25/FW25 - BLK
8	5025154	8	WASHER, 1/4 SAE
9	5025391	11	NUT, 1/4-20 HEX NYLOCK FLANGE
10	5025010X6	6	BOLT-1/4-20 X 3/4 GD5 CZ
11	5104401	1	ROD, PARKING BRAKE, SW25
12	5025510	1	GRIP, FOAM, 1/4 X 1 X 4.1
13	5025126	1	NUT, 1/4-20 HEX SERR. FLANGE
14	5025010X18	1	BOLT, 1/4-20 X 2-1/4 GD5 CZ
15	5010213	1	SPRING-EXT, .740 ODX2.025LGX.072WR, BLK
16	5025158	2	WASHER, 1/2 SAE
17	5025203X10	2	PIN, COTTER, 1/8 X 1-1/4
18	5025155	2	WASHER, 5/16" SAE
19	5104496	2	ROD, BRAKE CTRL, LOWER, SW25/FW25
20	5025045	2	NUT, 5/16-24 HEX NYLON LOCK
21	80005053	2	BOLT, 1/4-20X1.000,GR5,STD NECK,SQ ZC/CL
22	5025010X8	1	BOLT, 1/4-20 X 1" GD5 CZ
23	5025126	2	NUT, 1/4-20 HEX SERR. FLANGE
24	1960715	2	CREW-TRUSS HD TORX DR 1/2-20X0.750 T27
25	5104748	2	COLLAR, DOUBLE SPLIT, 7MM

# Spindle SERVICE PARTS - 5061095

Note: Unless noted otherwise, use the standard torque specifications

Mfg. No: 5901887

5061095

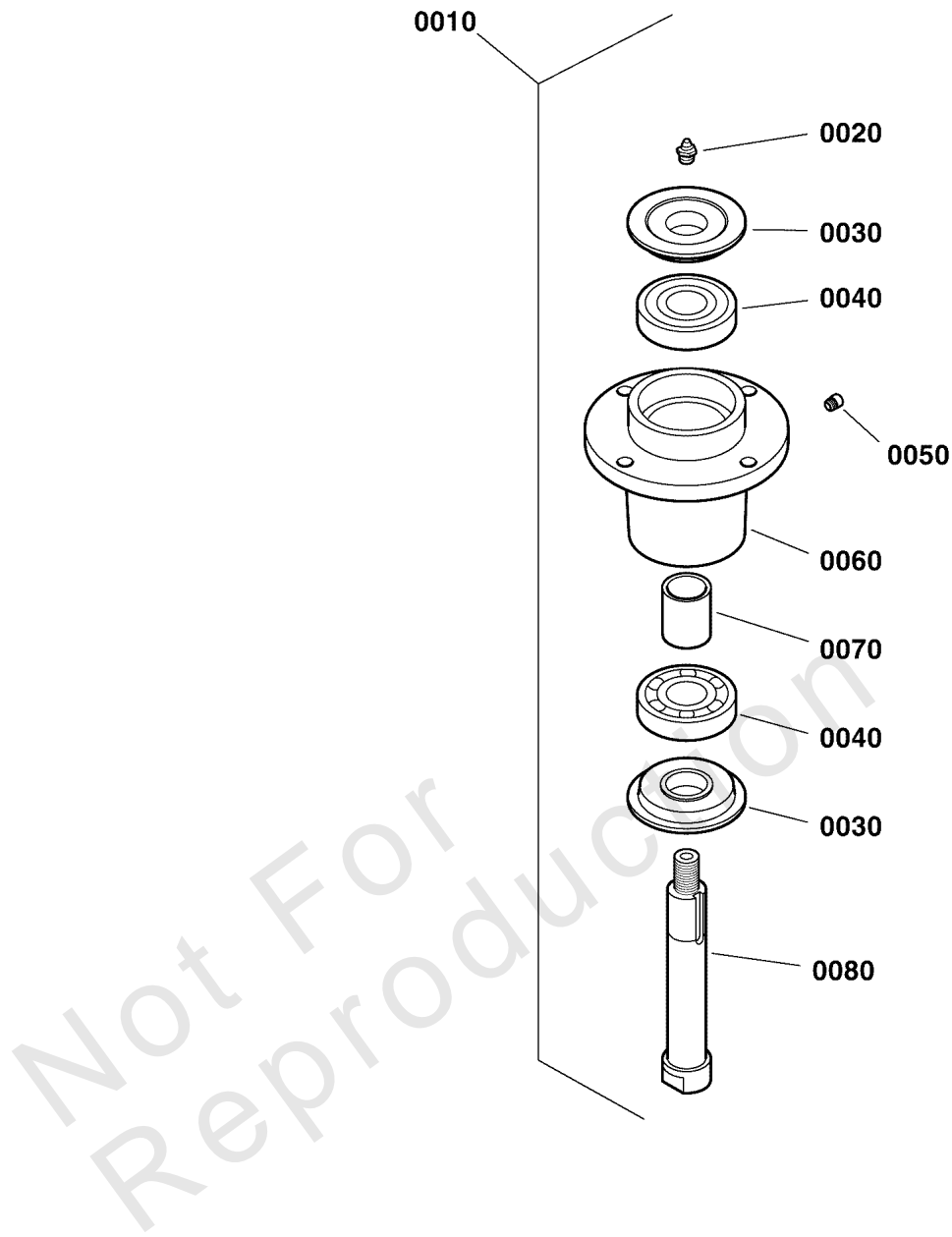

## Spindle SERVICE PARTS - 5061095

REF NO	PART NO	QTY	DESCRIPTION
0010	5061095	1	SPINDLE, ASSM, ALUMINUM - 5.25 -(Nut and Washer Sold Separately) (Includes items #0020 - 0080)
0020	5023329	1	FITTING, 1/8 NPT STR, SHORT
0030	5049793	2	TRASH SHIELD
0040	5023330	2	BEARING, .98 X 2.44 X .67
0050	5023296	1	FITTING, RELIEF, 1-5 PSI
0060	5061097	1	HOUSING, SPINDLE
0070	5061099	1	SPACER, 1.00 X 1.25 X 1.75
0080	5061098	1	SPINDLE SHAFT

Not For Reproduction

# Transaxle Drive Group

Note: Unless noted otherwise, use the standard torque specifications

Mfg. No: 5901887

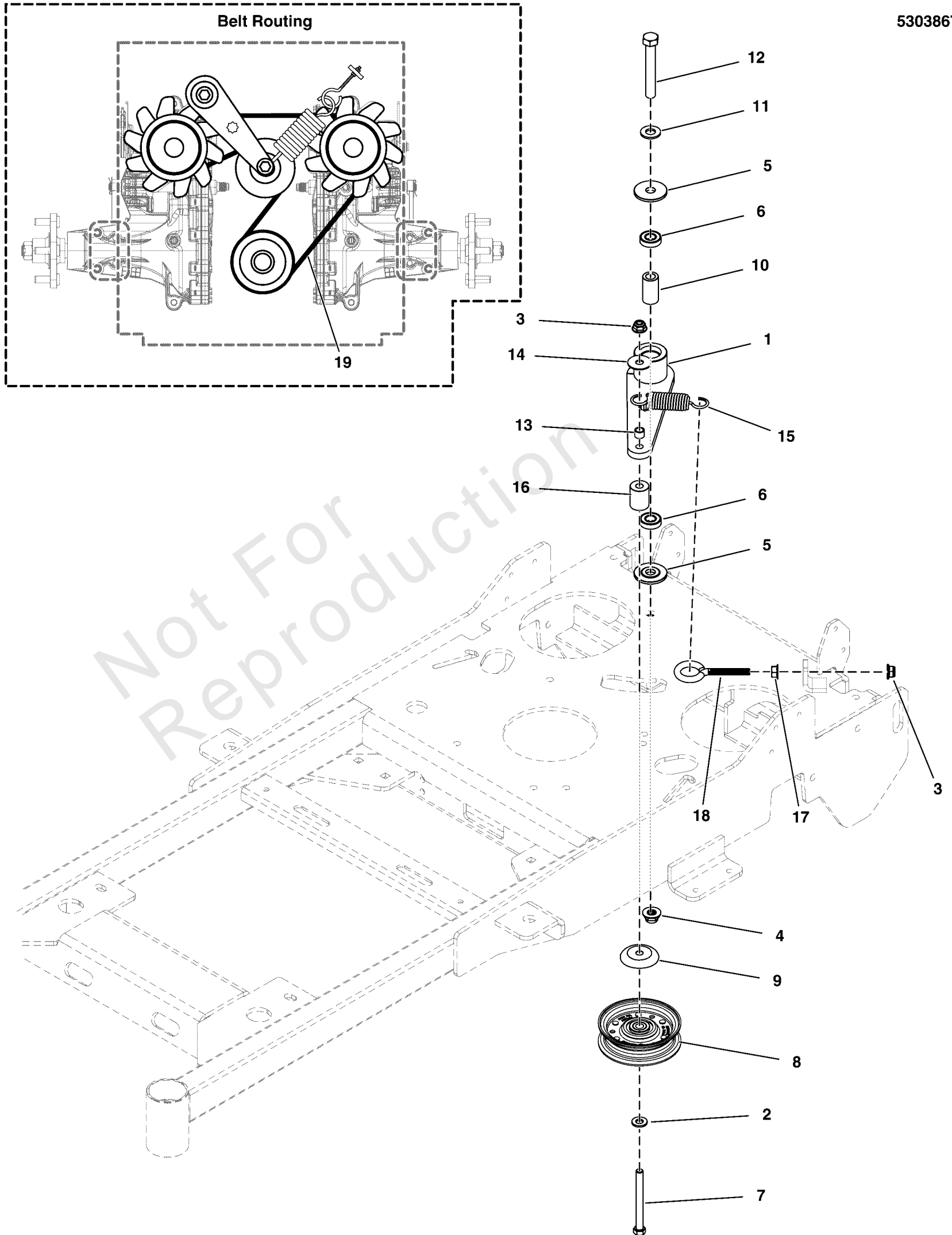

5303867

## Transaxle Drive Group

REF NO	PART NO	QTY	DESCRIPTION
1	5413130A	1	WELD, IDLER ARM, 6.63" LG - BLK
2	5025293	1	WASHER, 3/8" GR. 9 FLAT
3	5025394	2	NUT, 3/8 - 16 HEX NYLOCK FLANGE
4	5025396	1	NUT, Hex Flange, Nylock, 1/2-13
5	5103262	2	SPACER, IDLER ARM, 1/2, PM
6	7078243	2	BEARING, BALL, AXLE
7	5025013X28	1	BOLT, 3/8-16 X 3-1/2" GD5 CZ
8	5104514	1	PULLEY, FLAT IDLER, FLG, 4"ODX3/8"ID, CZ
9	5103787	1	SHIELD, BEARING PULLEY, 3/8ID, CZ
10	5103812	1	SPACER, .52 X .84 X 1.53, PM
11	5025158	1	WASHER, 1/2 SAE
12	5025017X28	1	BOLT, 1/2-13 X 3-1/2, HEX HD, GD5, CZ (SV)
13	1611705	1	SPACER-0.385ID 0.623OD 0.290LG P'MTL
14	5025401	1	WASHER, 3/8" USS
15	5104545	1	SPRING-EXT, 1.125 ODX4.679LGX.146WR, BLK
16	5103427	1	SPACER, .39 X 1.00 X 1.25, PM, CZ
17	5025128	1	NUT, 3/8-16 Hex Large Serrated Flange
18	5025429	1	EYEBOLT, 3/8-16 X 4, 2.13THRD, .75EYE, C
19	5104354	1	BELT, A-SEC, COG TYPE, 57" EL, ARAMID

**5102154**

**Hydro-Gear® Model ZJ-KMFE-3B5A-1PLX (P/N 5102154)**

- Hydro-Gear® Model ZJ-GMFE-3B51-1PLX (P/N 5102155)
- Hydro-Gear® Model ZJ-KMFE-3B5C-1PLX (P/N 5102810)
- Hydro-Gear® Model ZJ-GMFE-3B5B-1PLX (P/N 5101809)
- Hydro-Gear® Model ZJ-GMFE-3L5B-1PXX (P/N 5104471)
- Hydro-Gear® Model ZJ-KMFE-3L5C-1PXX (P/N 5104472)
- Hydro-Gear® Model ZL-GMFE-3L5B-1PXX (P/N 5104707)
- Hydro-Gear® Model ZL-KMFE-3L5C-1PXX (P/N 5104706)

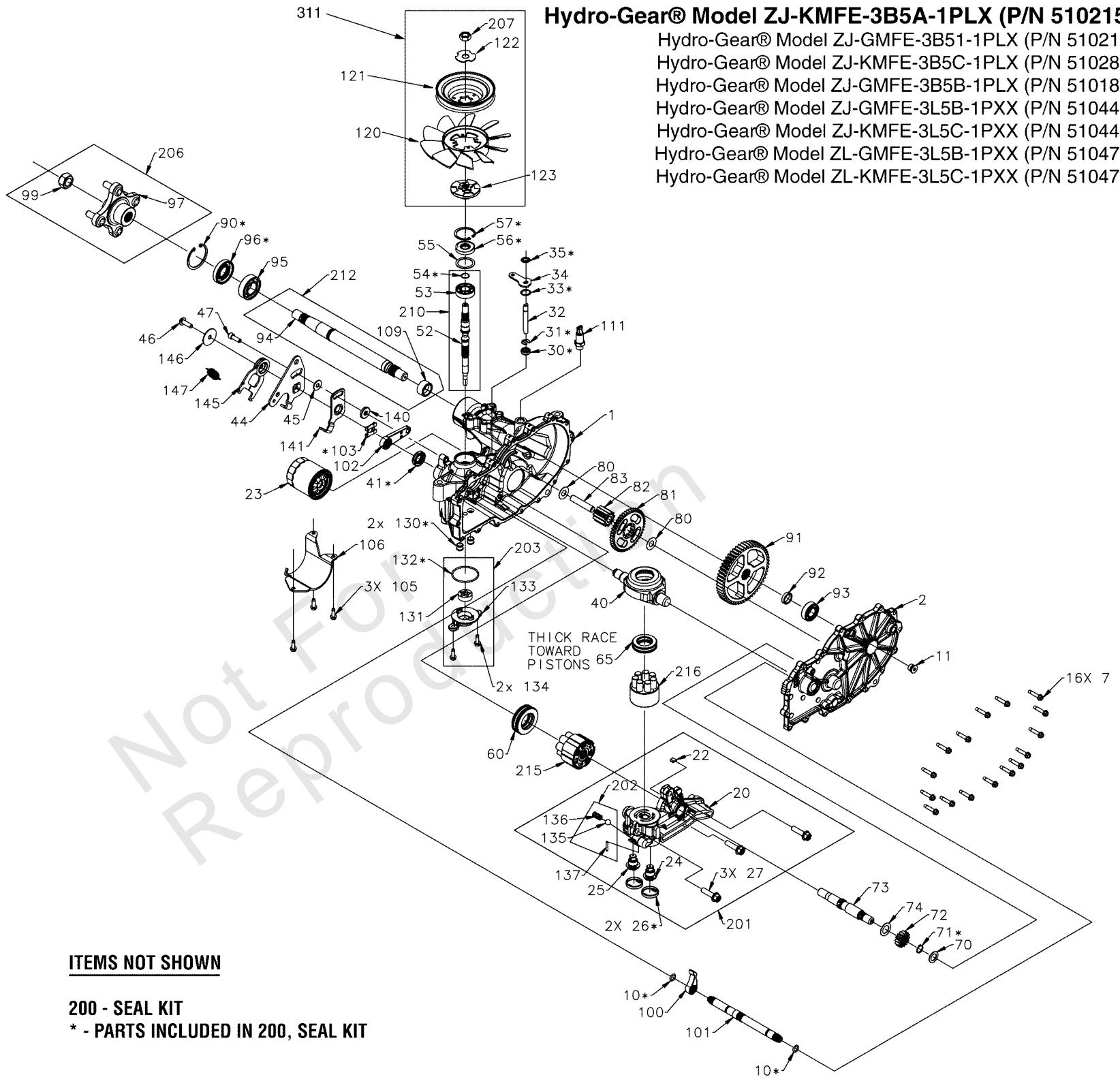

## Transaxle SERVICE PARTS - ZT3100

REF NO	PART NO	QTY	DESCRIPTION
23	5101026X1	1	FILTER, OIL, ZT2800
41	5101026X2	1	SEAL, CONTROL ARM, 18X32X7, #51140
56	5100161X3	1	OUTPUT SHAFT SEAL, 17X40X7, HR #51161
57	5101026X4	1	RING, RET 2.06 INT,
95	5101026X5	1	BEARING BALL, 1.0 X 52 X 15 OPEN 6205M
96	5101026X16	1	SEAL, LIP, AXLE, #53699
120	5101024X1	1	FAN
121	5102154X1	1	PULLEY, 4.5 INCH, HG #52364
121	5101024X2	1	PULLEY, HG #53804
122	5102914	1	WASHER, ZT5400, SLOTTED
123	5101024X3	1	HUB
200	5101026X8	1	KIT SEAL
203	5101026X12	1	KIT, CHARGE PUMP, ZT2800, ZT3100
206	5103382	1	HUB, ASM, TRANS 5101188/89 & 5102154/55
207	5102916	1	NUT, ZT5400
210	5101026X9	1	KIT, INPUT SHAFT
311	5102809X1	1	KIT, FAN AND PULLEY (72134)
1000	5104580X4	1	KIT, PLUG, BRAKE BORE, OUTBOARD -(FW25 & SW25 - S/N: All; FW35 & SW35 - S/N: 2017170235 & Above)
1001	5104580X5	1	KIT, PLUG, BRAKE BORE, INBOARD -(FW35 & SW35 - S/N: 2017170234 & Below)

### Front Wheels & Tires

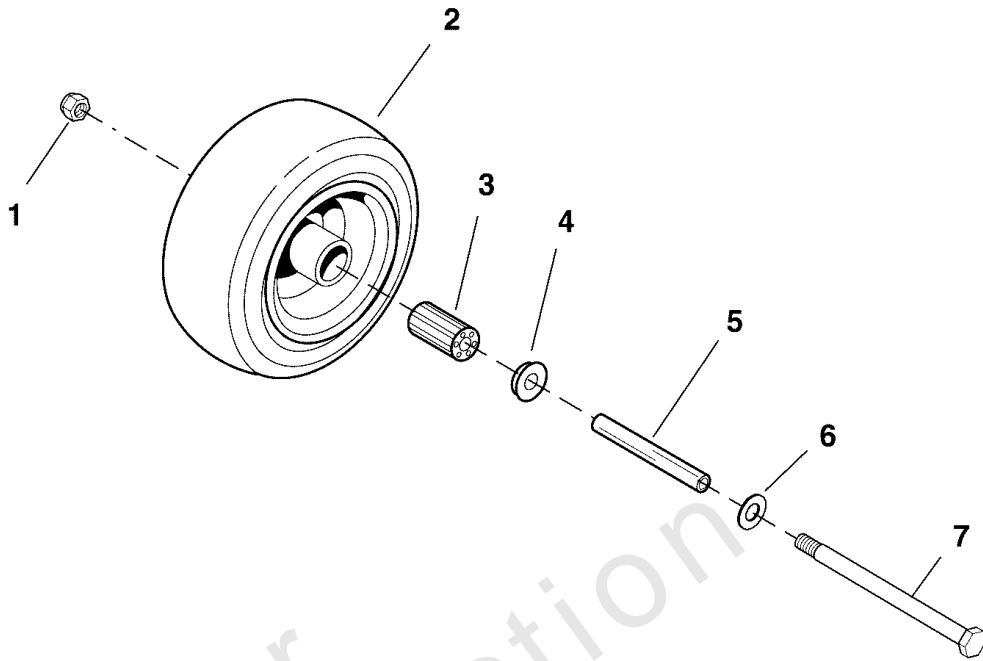

**Flat Free Tire**

### Rear Wheels & Tires

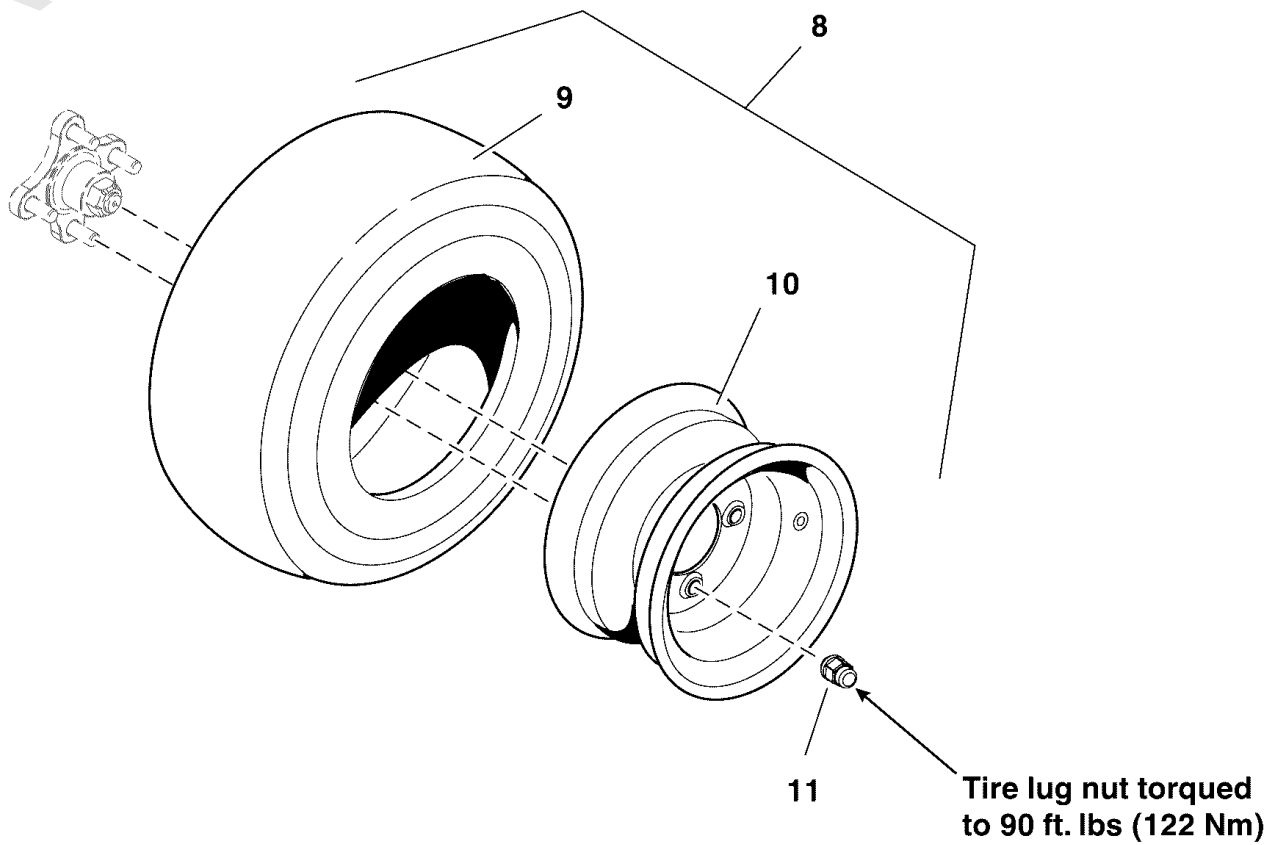

**Inflate to 15 psi (1,03 bar)**



## Wheel & Tire Group

REF NO	PART NO	QTY	DESCRIPTION
1	5025396	2	NUT, Hex Flange, Nylock, 1/2-13
2	5109036	2	TIRE ASM, 9 X 3.5-4 FF/CB, BLK
3	5021182	2	BEARING, ROLLER 3/4" ID X 3.25" (ONE PER TIRE)(SV) -(SV)
4	5021043	4	RETAINER, BEARING -(SV)
5	5041657	2	AXLE, CASTER WHEEL
6	5025158	2	WASHER, 1/2 SAE
7	5025017X48	2	BOLT, 1/2-13 X 6 GD5 CZ
8	5109045	2	TIRE ASM, 20 X 7 - 10, TURF, 4 BOLT, BLK
9	5101068X1	2	TIRE, 20X7.00-10NHS, TURF MASTER -(SV)
10	-----	2	WHEEL RIM -(Not serviceable)
11	-----	10	LUG NUT, Black -(Originally Black Lug nut - Replacement 5020601SM is silver in color).
11	5020601SM	10	NUT, 1/2-20, FOR WHEEL BOLT SILVER -(Replacement 5020601SM is silver in color).

# Hardware Identification & Torque Specifications

Torque Specification Chart								
FOR STANDARD METRIC MACHINE HARDWARE (Tolerance ± 20%)								
Property Class	5.6		8.8		10.9		12.9	
	Class 5.6		Class 8.8		Class 10.9		Class 12.9	
Size Of Hardware	in/lbs	Nm.	in/lbs	Nm.	in/lbs	Nm.	in/lbs	Nm.
	ft/lbs		ft/lbs		ft/lbs		ft/lbs	
M3	5.88	.56	13.44	1.28	19.2	1.80	22.92	2.15
M4	13.44	1.28	30.72	2.90	43.44	4.10	52.56	4.95
M5	26.4	2.50	60.96	5.75	5.97	8.10	7.15	9.7
M6	44.64	4.3	7.3	9.9	10.3	14	12.1	16.5
M7	5.2	7.1	12.1	16.5	16.9	23	19.9	27
M8	7.7	10.5	17.7	24	25	34	29	40
M10	15	21	35	48	50	67	59	81
M12	26	36	61	83	86.2	117	103	140
M14	42	58	101	132	136	185	162	220
M16	64	88	147	200	210	285	250	340
M18	89	121	202	275	287	390	346	470
M20	126	171	290	390	405	550	486	660
M22	169	230	390	530	559	745	656	890
M24	217	295	497	375	708	960	840	1140
M27	320	435	733	995	1032	1400	1239	1680
M30	435	590	995	1350	1401	1900	1681	2280
M33	590	800	1349	1830	1902	2580	2278	3090
M36	759	1030	1740	2360	2441	3310	2935	3980
M39	988	1340	2249	3050	3163	4290	3798	5150

Torque Specification Chart						
FOR STANDARD MACHINE HARDWARE (Tolerance ± 20%)						
Hardware Grade	No Marks		SAE Grade 5		SAE Grade 8	
	SAE Grade 2		SAE Grade 5		SAE Grade 8	
Size Of Hardware	in/lbs	Nm.	in/lbs	Nm.	in/lbs	Nm.
	ft/lbs		ft/lbs		ft/lbs	
8-32	19	2.1	30	3.4	41	4.6
8-36	20	2.3	31	3.5	43	4.9
10-24	27	3.1	43	4.9	60	6.8
10-32	31	3.5	49	5.5	68	7.7
1/4-20	66	7.6	8	10.9	12	16.3
1/4-28	76	8.6	10	13.6	14	19.0
5/16-18	11	15.0	17	23.1	25	34.0
5/16-24	12	16.3	19	25.8	29	34.0
3/8-16	20	27.2	30	40.8	45	61.2
3/8-24	23	31.3	35	47.6	50	68.0
7/16-14	30	40.8	50	68.0	70	95.2
7/16-20	35	47.6	55	74.8	80	108.8
1/2-13	50	68.0	75	102.0	110	149.6
1/2-20	55	74.8	90	122.4	120	163.2
9/16-12	65	88.4	110	149.6	150	204.0
9/16-18	75	102.0	120	163.2	170	231.2
5/8-11	90	122.4	150	204.0	220	299.2
5/8-18	100	136	180	244.8	240	326.4
3/4-10	160	217.6	260	353.6	386	525.0
3/4-16	180	244.8	300	408.0	420	571.2
7/8-9	140	190.4	400	544.0	600	816.0
7/8-14	155	210.8	440	598.4	660	897.6
1-8	220	299.2	580	788.8	900	1,244.0
1-12	240	326.4	640	870.4	1,000	1,360.0

The guides and ruler furnished below are designed to help you select the appropriate hardware.



Nut, M8

Thread Diameter (mm)

Inside Diameter (in)      Threads per inch

Nut, 1/2-16

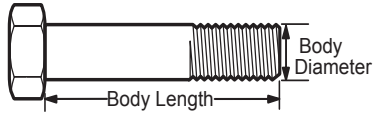

Screw, M8- 1.25 x 25

Thread Diameter (mm)      Distance between threads (mm)      Body Length (mm)

Body Diameter      Threads per inch      Body Length (in)

Screw, 1/2- 16 x 2



## Standard Hardware Sizing

When a washer or nut is identified as 1/2" (M8), this is the *Nominal size*, meaning the *inside diameter* is 1/2 inch (8mm metric thread diameter); if a second number is present it represents the *threads per inch* (distance between threads).

When bolt or capscrew is identified as 1/2 - 16 x 2" (M8 - 1.25 x 50), this means the *Nominal size*, or body diameter is 1/2 inch (8mm metric thread diameter), the second number, 16, represents the *threads per inch*, (*distance between threads*). The final number is the body length of the bolt or screw, 2 inches (50mm).

## NOTES

- These torque values are to be used for all hardware excluding: locknuts, self-tapping screws, thread forming screws, sheet metal screws and socket head setscrews.
- Recommended seating torque values for locknuts:
  - for prevailing torque locknuts - use 65% of grade 5 torques.
  - for flange whizlock nuts and screws - use 135% of grade 5 torques.
- Unless otherwise noted on assembly drawings, all torque values must meet this specification.

## Common Hardware Types

Hex Head Capscrew

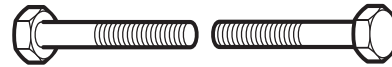

Washer



Carriage Bolt



Hex Nut

## Wrench & Fastener Size Guide

1/4" Bolt or Nut Wrench—7/16"	5/16" Bolt or Nut Wrench—1/2"	3/8" Bolt or Nut Wrench—9/16"	7/16" Bolt or Nut Wrench (Bolt)—5/8" Wrench (Nut)—11/16"	1/2" Bolt or Nut Wrench—3/4"
M6 Bolt or Nut Wrench—10mm	M8 Bolt or Nut Wrench—13mm	M10 Bolt or Nut Wrench—17mm	M12 Bolt or Nut Wrench—19mm	M14 Bolt or Nut Wrench—22mm

