



# Parts Manual

Mfg. No: 5901895  
F60Z Series w/ 36" Mower Deck  
(F60ZKAV1936)





<b>Model Components</b>	<b>Page</b>
36" Mower Deck Group - Hanger Chains. ....	4
36" Mower Deck Group - Housing, Covers, Spindles & Blades. ....	6
36" Mower Deck Group - Pulleys, Belt & Idler Arm. ....	8
Decal Group - Brand & Model. ....	10
Decal Group - Safety and Operation (North America Models) S/N: 4000812085 and Below. ....	12
Decal Group - Safety and Operation (North America Models) S/N: 4000812086 and Above. ....	14
Deck Lift Group. ....	16
Electrical Group - Kawasaki. ....	18
Electrical Schematic - Charging Circuit - S/N: 2017954955 & Below. ....	20
Electrical Schematic - Charging Circuit - S/N: 2017954956 & Above. ....	22
Electrical Schematic - Cranking Circuit - S/N: 2017954955 & Below. ....	24
Electrical Schematic - Cranking Circuit - S/N: 2017954956 & Above. ....	26
Electrical Schematic - Ign. Ground Circuit/Op Pres. - S/N: 2017954955 & Below. ....	28
Electrical Schematic - Ign. Ground Circuit/Op. Pres. - S/N: 2017954956 & Above. ....	30
Electrical Schematic - PTO Clutch Circuit - S/N: 2017954955 & Below. ....	32
Electrical Schematic - PTO Clutch Circuit - S/N: 2017954956 & Above. ....	34
Engine & PTO Group - Kawasaki. ....	36
Fuel Supply Hose, Tank Replacement Parts, and Evap Group. ....	38
Fuel Tank and Mount Group. ....	40
Hydraulic Group. ....	42
Instrument Control Panel Group. ....	44
Main Frame & Front Casters Group. ....	46
Motion Control Group. ....	48
Parking Brake Group. ....	50
Rear Bumper Group. ....	52
Seat Mount and Floor Group S/N: 4000369918 and Below. ....	54
Seat Mount and Floor Group S/N: 4000369919 to 4000875836. ....	56
Seat Mount and Floor Group S/N: 4000875837 and Above. ....	58
Spindle SERVICE PARTS - 5061095. ....	62
Transaxle Drive Group - Kawasaki Models. ....	64
Transmission SERVICE PARTS. ....	66
Wheel & Tire Group. ....	68
Torque Specification Chart. ....	70

# 36" Mower Deck Group - Hanger Chains

Note: Unless noted otherwise, use the standard torque specifications

Mfg. No: 5901895

5301476F

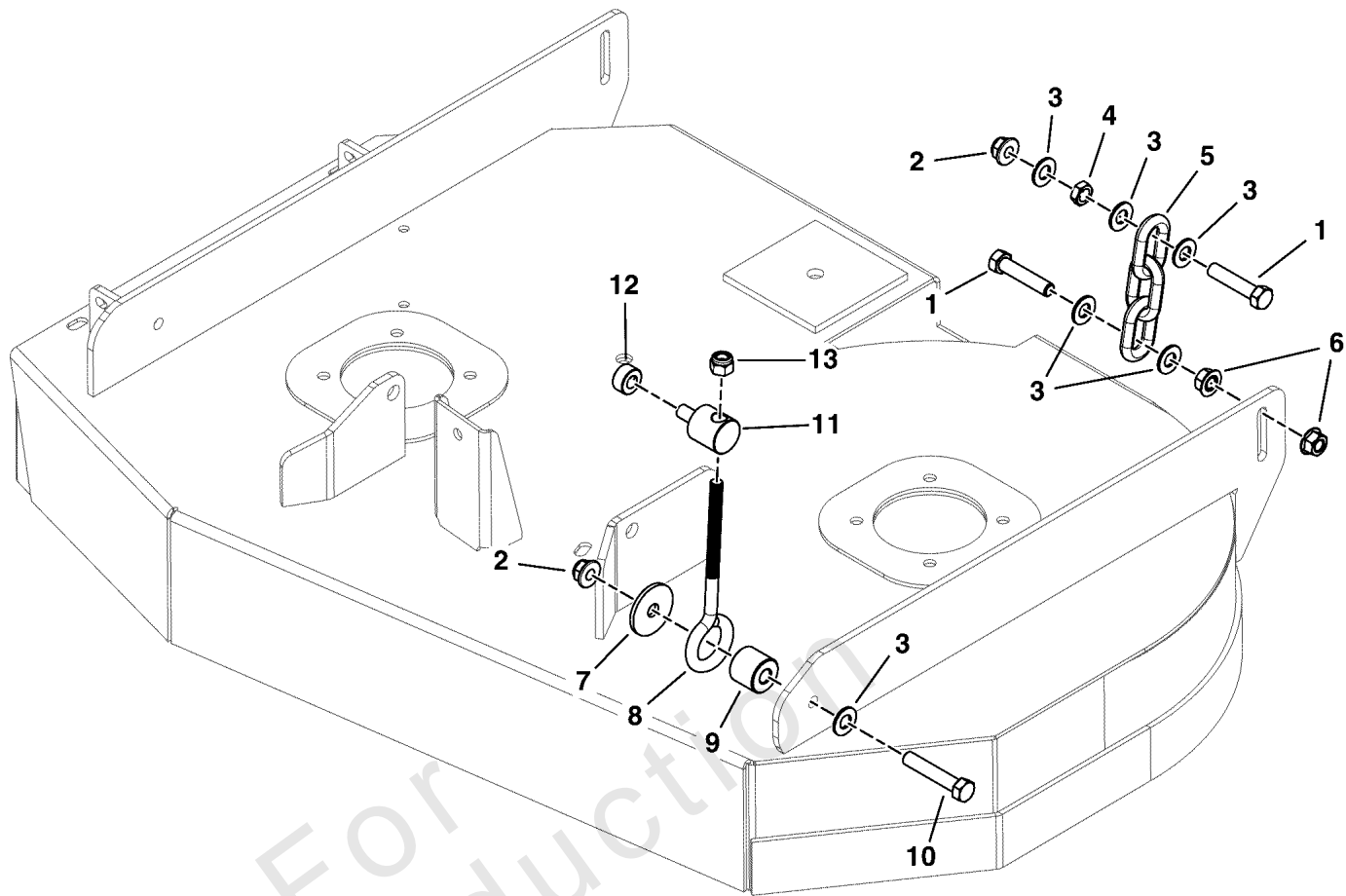

### 36" Mower Deck Group - Hanger Chains

REF NO	PART NO	QTY	DESCRIPTION
1	5025013X14	4	BOLT, 3/8-16 X 1-3/4" GD5 CZ
2	5025394	4	NUT, 3/8-16 HEX NYLOCK FLANGE
3	5025156	12	WASHER, 3/8 SAE
4	5025084	2	NUT, 3/8-16 HEX JAM
5	5050878X3	2	CHAIN, 5/16 GD30, 3 LINKS
6	5025128	4	NUT, 3/8-16 HEX SERRATED FLANGE
7	5100548	2	WASHER, .390 X 1.50 X .109, CZ
8	5025489	2	EYE BOLT, 3/8-16X6,3THRD,1EYE,CZ, WELDED
9	5043815	2	SPACER, .39 X 1.00 X .75, CZ
10	5025013X16	2	BOLT, 3/8-16 X 2, GD5, CZ
11	5101611	2	ADJUSTER, BRAKE LINKAGE
12	5010546	2	COLLAR, 3/8 SET
13	5025096	2	NUT, 3/8-16 HEX NYLON LOCK

Not For Reproduction

# 36" Mower Deck Group - Housing, Covers, Spindles & Blades

Note: Unless noted otherwise, use the standard torque specifications

Mfg. No: 5901895

5304651  
5304844

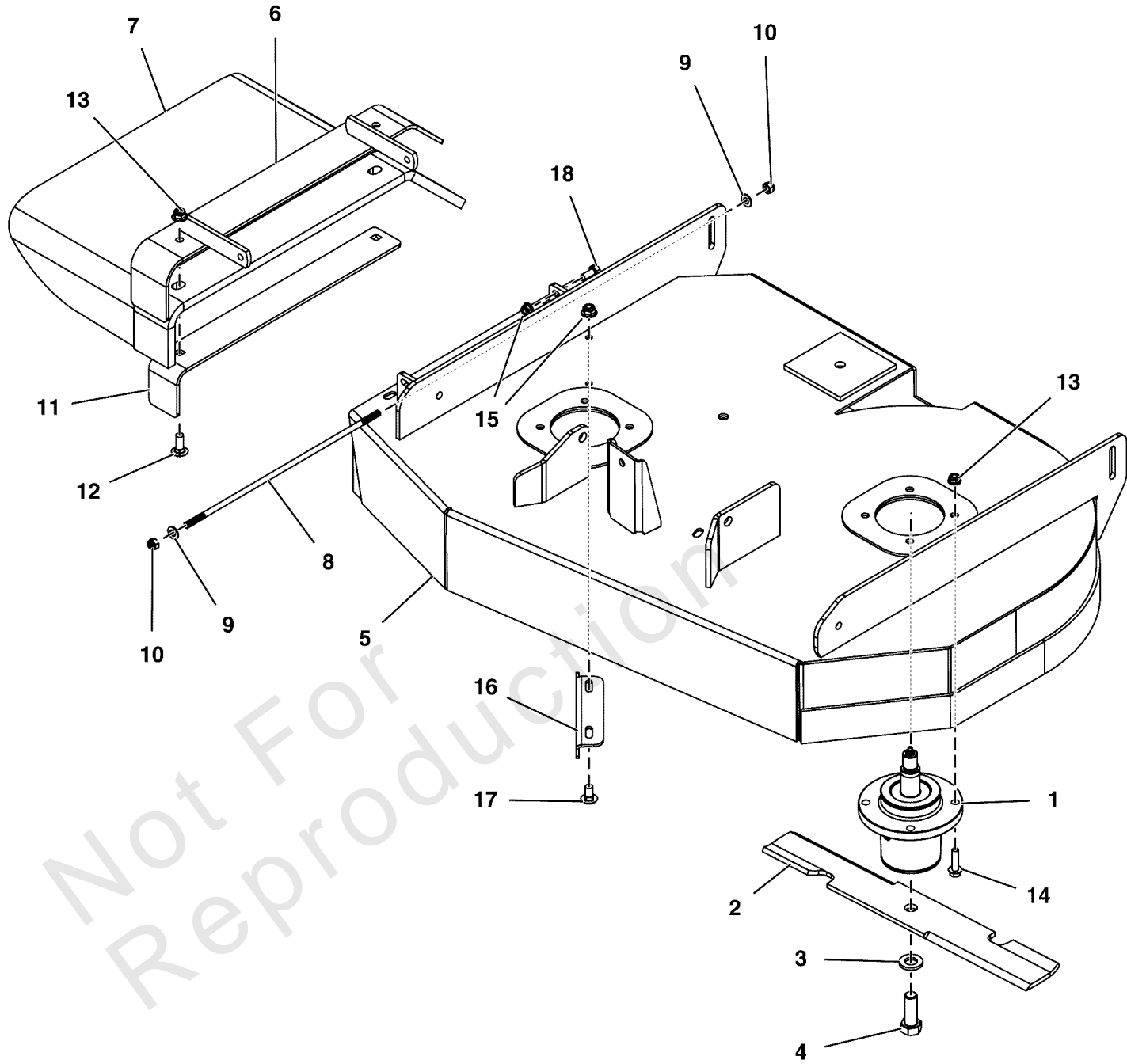

### 36" Mower Deck Group - Housing, Covers, Spindles & Blades

REF NO	PART NO	QTY	DESCRIPTION
1	5061095	2	SPINDLE, ASSM, ALUMINUM - 5.25
2	5101756X2	1	BLADE SET, 36 DECK (2)
3	5025477	2	WASHER, BLADE BOLT, 9/16" F436, CZ
4	5025320X14	2	BOLT, 5/8-11 X 1-3/4 GD8
5	5600982	1	DECK SHELL W/DECALS, 36, F60Z (5415641B)
6	5413404A	1	WELD, MOUNT, DISCHARGE CHUTE - BLK
7	5413498	1	CHUTE, RUBBER DISCHARGE CHUTE (5104441)
8	5042555	1	ROD, 5/16 X 13.75, TBE, CZ
9	5025155	2	WASHER, 5/16" SAE
10	5025045	2	NUT, 5/16-24 HEX NYLON LOCK
11	5413401A	1	SUPPORT, DISCHARGE CHUTE - BLK
12	5025146X12	2	BOLT, 3/8-16 X 1-1/2, CARRIAGE, GD5, CZ
13	5025394	10	NUT, 3/8-16 HEX NYLOCK FLANGE
14	5025390X10	8	BOLT, 3/8-16 X 1 1/4 FLANGE
15	5025392	3	NUT, 5/16-18 HEX NYLOCK FLANGE
16	5415547A	1	PLATE, DEFLECTOR, 36" - BLK
17	5025145X6	2	BOLT, 5/16-18 X 3/4, CARRIAGE
18	5025011X6	1	BOLT, 5/16-18 X 3/4 GD5

# 36" Mower Deck Group - Pulleys, Belt & Idler Arm

Note: Unless noted otherwise, use the standard torque specifications

Mfg. No: 5901895

5304650

## Deck Drive Belt Routing

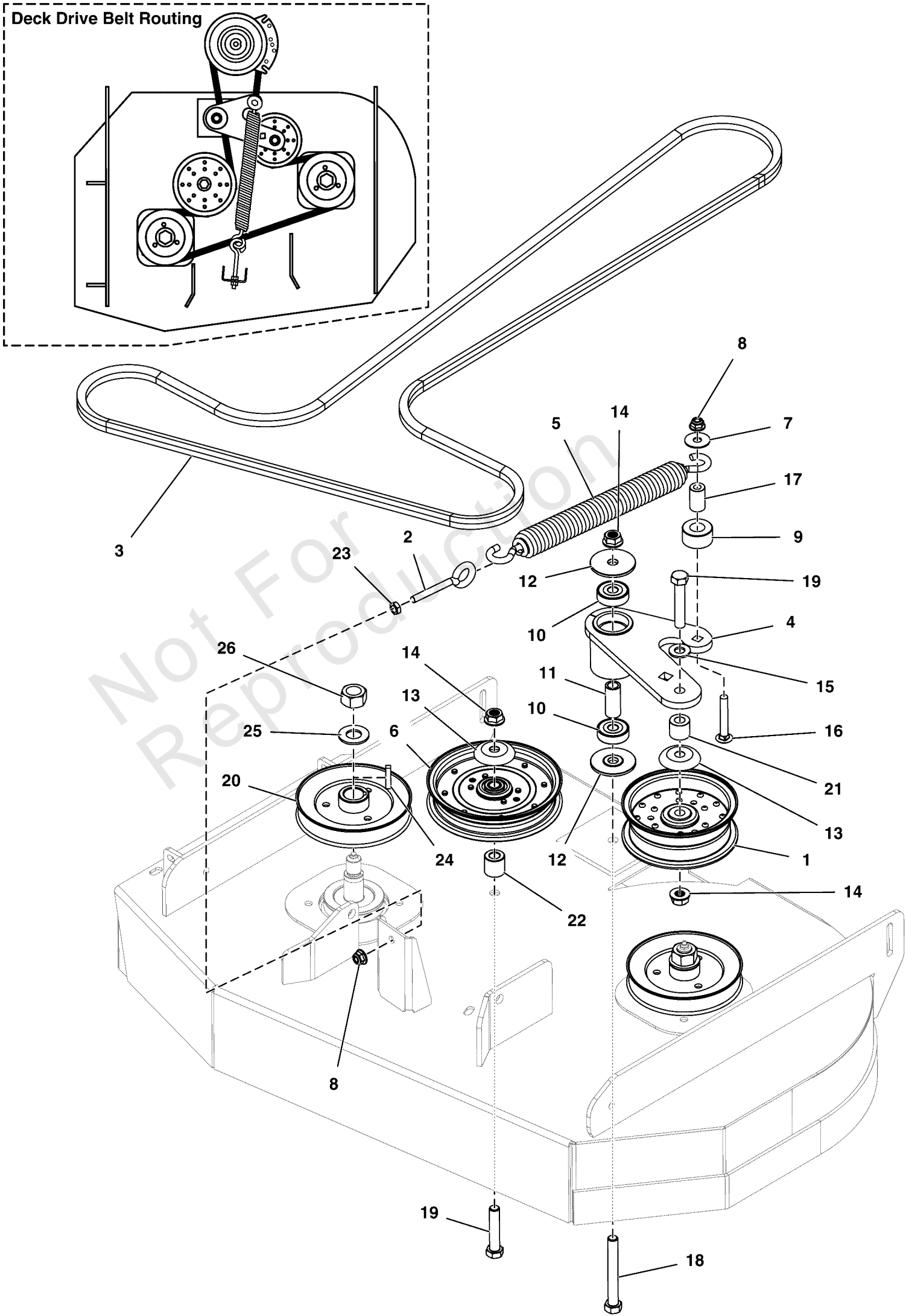



### 36" Mower Deck Group - Pulleys, Belt & Idler Arm

REF NO	PART NO	QTY	DESCRIPTION
1	5101312	1	PULLEY, IDLER, 5.00 WIDE W/ .51 BORE
2	5021812	1	EYE BOLT, 3/8-16 X 6, 3THRD, 1EYE, CZ
3	5105139	1	BELT, B-SEC, 118.78" EL, 2H ARAMID, WRPD
4	5415360A	1	WELD, IDLER ARM, 36" - BLK
5	5023392	1	SPRING-EXT, 1.393 ODX13.25LGX.218WR, BLK
6	-----	1	Replace with: Pulley #5104717 & Debris Shield #5105145
7	5025165	1	WASHER, 3/8" Fender
8	5025394	2	NUT, 3/8 - 16 HEX NYLOCK FLANGE
9	5400756	1	SPACER, .76X 1.50 X .79, CZ
10	5104383	2	BEARING, 6203-1/2", SEALED
11	5104381	1	SPACER, .510 X .750 X 1.749, CZ
12	5104379	2	SPACER, IDLER ARM, 1/2 X 2.25
13	5101103	2	SHIELD, PULLEY BEARING, CZ
14	5025396	2	NUT, Hex Flange, Nylock, 1/2-13
15	5025158	1	WASHER, 1/2 SAE
16	5025146X20	1	BOLT, 3/8-16 X 2-1/2, CARRIAGE, GD5, CZ
17	5101245	1	SPACER, .38 X .75 X 1.25, YZ
18	5025017X36	1	BOLT, 1/2-13 X 4-1/2" GD5 YZ
19	5025017X22	2	BOLT, 1/2-13 X 2-3/4 GD5 CZ
20	5101351	2	PULLEY, 5.926OB X .985ID, SINGLE B-SEC
21	5044673	1	SPACER, .52 X 1.00 X .88, PM, CZ
22	5049777	1	SPACER, .52 x 1.00 x 1.00
23	5025084	1	NUT, 3/8-16 HEX JAM
24	5050407X10	2	KEY, 1/4" SQ. X 1-1/4
25	5025406	2	WASHER, 3/4 BELLEVILLE CL/ZC
26	5025405	2	NUT, 3/4-16 Hex

**Decal Group - Brand & Model**

Note: Unless noted otherwise, use the standard torque specifications

Mfg. No: 5901895

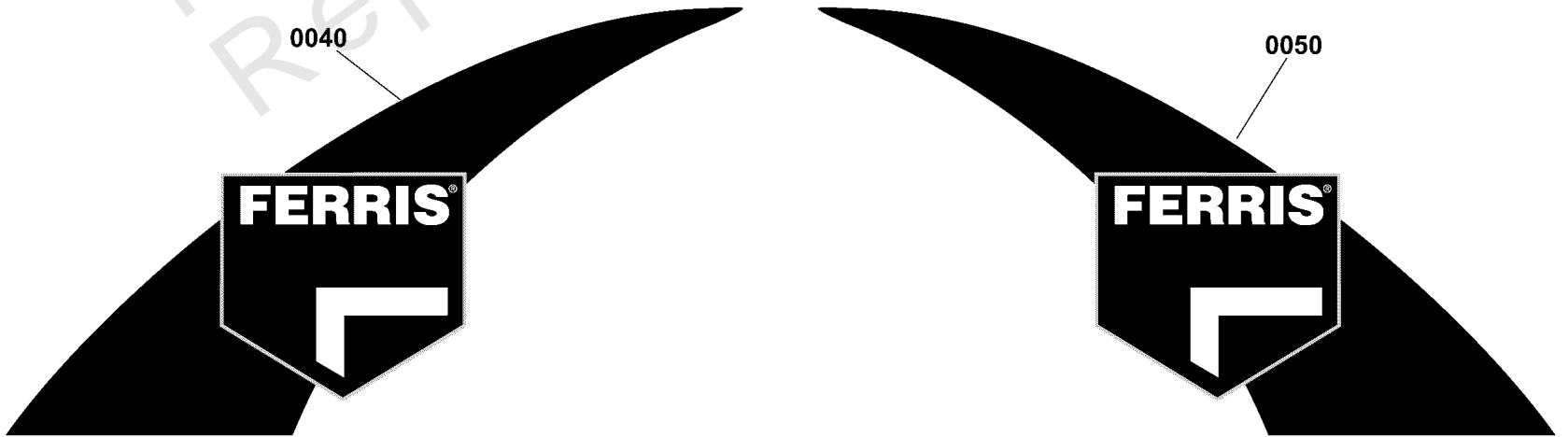
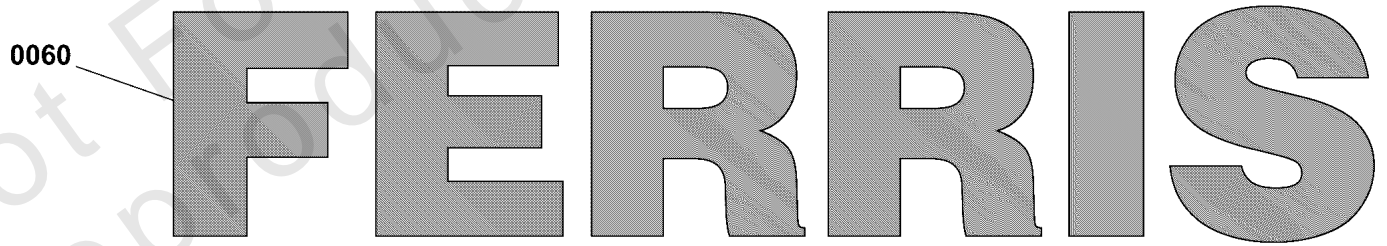
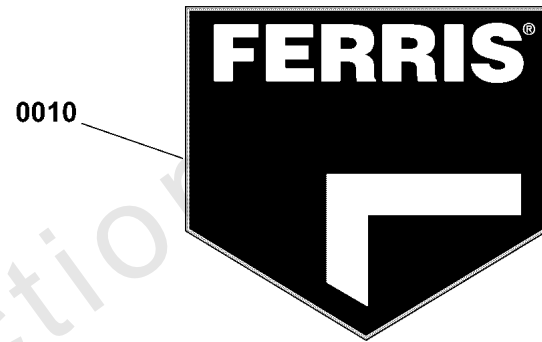
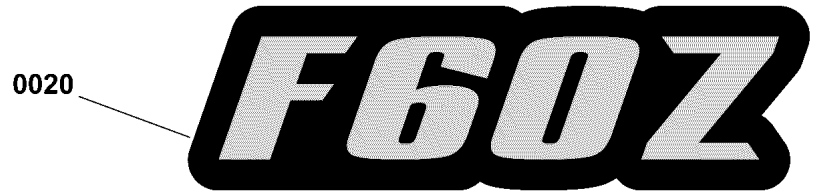
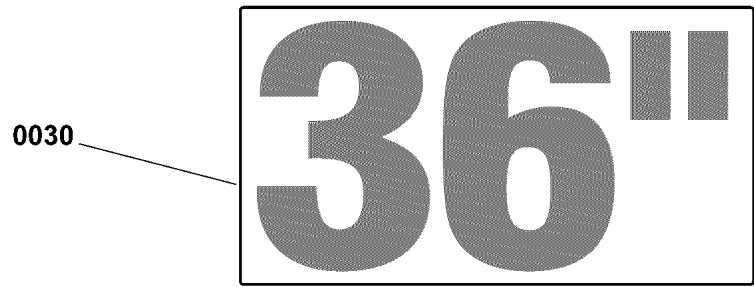
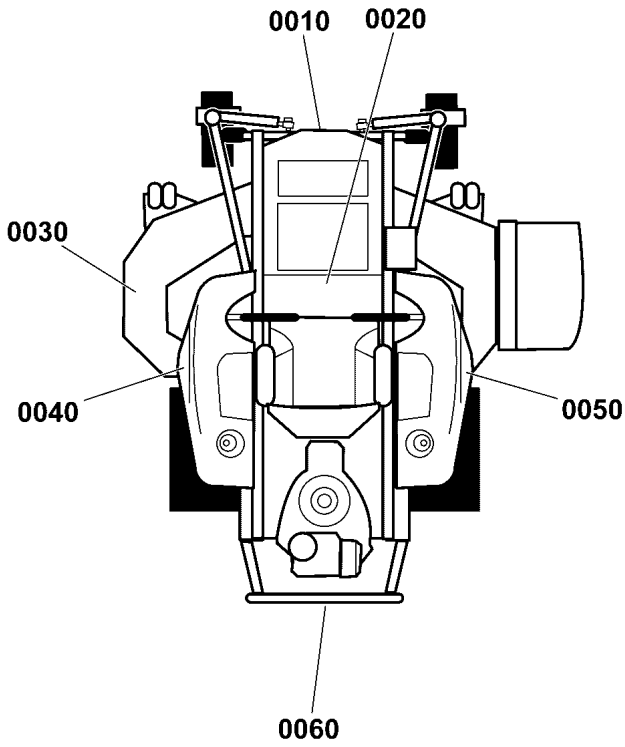

### *Decal Group - Brand & Model*

---

REF NO	PART NO	QTY	DESCRIPTION
0010	5104724	1	DECAL, FERRIS LOGO, MEDIUM
0020	5105075	1	DECAL, MODEL, F60Z
0030	5101322	1	DECAL, 36"
0040	5109091	1	DECAL, TANK, SML, LH, FERRIS
0050	5109092	1	DECAL, TANK, SML, RH, FERRIS
0060	5103799	1	DECAL, FERRIS, 2.23" X 11.39"

Not For Reproduction

# Decal Group - Safety and Operation (North America Models) S/N: 4000812085 and Below

Note: Unless noted otherwise, use the standard torque specifications

Mfg. No: 5901895

5304648  
5304876  
5304875

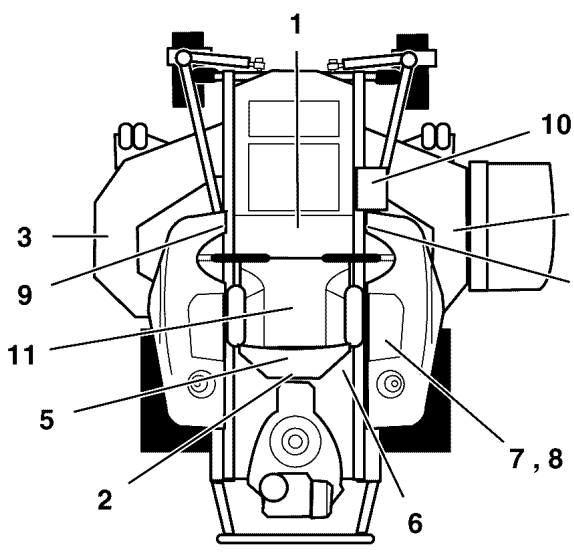

**WARNING**

**Avoid serious injury or death**

- Read operator's manual before using this product.
- Do NOT operate this machine unless you are trained.
- Know the location and function of all controls.
- Keep safety devices (guards, shields, switches, etc.) in place and working.
- Remove objects that could be thrown by the blade.
- Be sure blades and engine are stopped before placing hands or feet near blades.
- When leaving machine, shut off, remove key and set parking brake.

**Fire Hazard**

Gasoline is flammable. Debris is combustible.

- Allow engine to cool for at least 3 minutes before refueling.
- Keep unit cleaned of debris.
- This equipment may create sparks that can start fires around dry vegetation. A spark arrester may be required. Contact local fire agencies for regulations relating to fire prevention requirements.

**DANGER**

**Amputation hazard**

Rotating blades cut off arms and legs.

- Stop the mower when children or others are near.
- Do not carry riders (especially children) even with the blades off. They may fall off or return for another ride when you are not expecting it.
- Look down, behind and to the side before changing directions.

**Loss of control and roll-over hazard**

Operating on slopes can be hazardous and cause loss of control and roll-overs.

- Avoid sudden turns or rapid speed changes.
- Reduce speed and use extreme caution on slopes.
- Go across slopes, NOT up and down.
- Do not operate on slopes over 15 degrees.
- If machine stops forward motion on a slope, stop the blades and drive slowly off the slope.

15° Max.

**DANGER**

**Water, retaining walls and drop-off hazards**

Wheels dropping over edges may result in serious injury, death or drowning.

- Do NOT operate near water, retaining walls or drop-offs.
- Give yourself a minimum of two mower widths of clearance around these hazards.

**Wet or soft slope hazard**

Wet or soft slopes can cause sliding and loss of control.

- Do NOT operate on slopes when grass is wet.
- Do NOT operate on slopes when soil is soft (such as after heavy rains).

**WARNING**

**Amputation and Pinch Point Hazard**

To avoid injury from rotating parts, stay clear of parts and keep all shields and guards in place.

5103184

**DANGER**

**Amputation and thrown objects hazard**

- Keep hands and feet away from deck.
- Do not operate mower unless discharge chute or entire grass catcher is in its proper place.

7101865

The operator's manual is available in Spanish.  
La manual del operador está disponible en Español.

**Ignition System (Gasoline Models)**

This spark ignition system complies with Canadian standard ICES-002.

5100909

**HYDRAULIC OIL**

USE SAE 20W-50 MOTOR OIL

5100957

5100342

5100280

5100280

5105152

**Belts & Blades**

Tractor	
Pump Drive Belt	5022173
36" Mower	
Deck Drive Belt	5105139
Mower Blade (Set)	5101756X2
48" Mower	
Deck Drive Belt	5104064
Mower Blade (Set)	5101986S

5105152

***Decal Group - Safety and Operation (North America Models) S/N: 4000812085 and Below***

REF NO	PART NO	QTY	DESCRIPTION
1	5103595	1	DECAL, MAIN SAFETY
2	5103184	1	DECAL, WARNING, HAND IN BELT, ENG ONLY -(Located on plate between hydraulic oil tanks)
3	7101665	2	DECAL, DANGER DO NOT OPERATE W/O DEFLECT
4	5104269	1	DECAL, SPANISH MANUAL, IGES, C-TICK
5	5100957	1	DECAL, HYDRAULIC OIL, 20W50 -(Located on frame cross bar)
6	5100342	1	DECAL, FUEL VALVE -(Models with two fuel tanks)
7	5100280	1	DECAL, THROTTLE CONTROL
8	5048970	1	DECAL, IGNITION SWITCH
9	5104268	2	DECAL, TRANSAXLE RELEASE, WB
10	5101315	1	DECAL, CUT HEIGHT, S50X
11	5105152	1	DECAL, BELT & BLADE, F60Z

Not For Reproduction

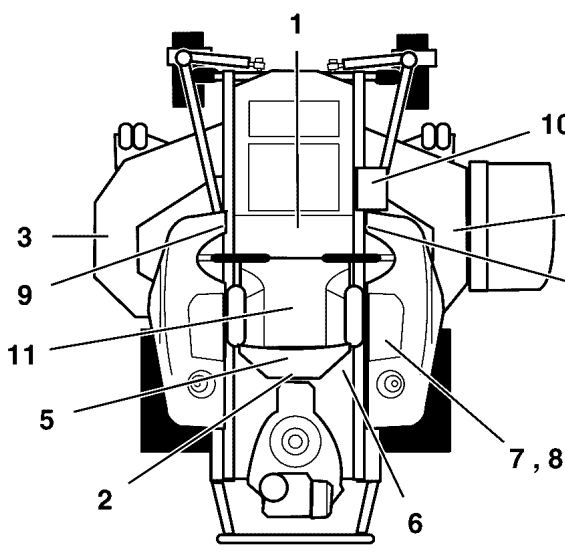

**WARNING**

Avoid serious injury or death.

- Read operator's manual before using this product.
- Do NOT operate this machine unless you are trained.
- Know the location and function of all controls.
- Keep safety devices (guards, shields, switches, etc.) in place and working.
- Remove objects that could be thrown by the blade.
- Be sure blades and engine are stopped before placing hands or feet near blades.
- When leaving machine, shut off, remove key and set parking brake.

**Fire hazard**  
Gasoline is flammable. Yard debris is combustible.

- Allow engine to cool for at least 3 minutes before refueling.
- Keep fuel cleaned of yard debris.
- This equipment may create sparks that can start fires around dry vegetation. A spark arrester may be required. Contact local fire agencies for regulations relating to fire prevention requirements.

**DANGER**

Rotating blades cut off arms and legs.

- Stop the mower when children or others are near.
- Do not carry riders (especially children) even with the blades off. They may fall off or return for another ride when you are not expecting it.
- Look down, behind and to the side before changing directions.

Operating on slopes can be hazardous and cause loss of control and roll-overs.

- Do not operate on slope over 15 degrees.
- Avoid sudden turns or rapid speed changes.
- Reduce speed and use extreme caution on slopes.
- Avoid turning down slopes, if possible turn up slopes.
- If machine stops forward motion on a slope, stop the blades and drive slowly off the slope.

Wheels cropping over edges may result in serious injury, death or drowning.

- Do NOT operate down slopes towards or near water, retaining walls or drop-offs.
- Give yourself a minimum of two mower widths of clearance around these hazards.

Wet or soft slopes can cause sliding and loss of control.

- Do NOT operate on slopes when grass is wet.
- Do NOT operate on slopes when soil is soft (such as after heavy rains).

**WARNING**

**Amputation and Pinch Point Hazard**

To avoid injury from rotating parts, stay clear of parts and keep all shields and guards in place.

**DANGER**

**Amputation and thrown objects hazard**

- Keep hands and feet away from deck.
- Do not operate mower unless discharge chute or entire grass catcher is in its proper place.

The operator's manual is available in Spanish. La manual del operador está disponible en Español.

**Ignition System (Gasoline Models)**  
This spark ignition system complies with Canadian standard ICES-002.

**HYDRAULIC OIL**

USE SAE 20W-50 MOTOR OIL

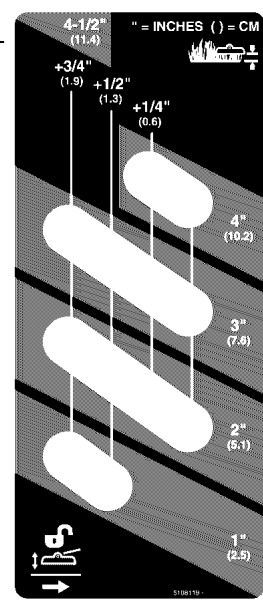
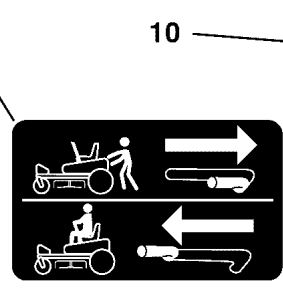
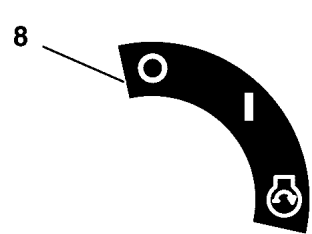
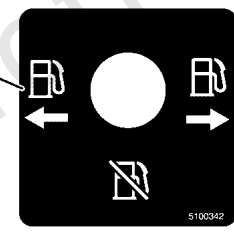

**Belts & Blades**

Tractor	
Pump Drive Belt	5022173
36" Mower	
Deck Drive Belt	5105139
Mower Blade (Set)	5101756X2
48" Mower	
Deck Drive Belt	5104064
Mower Blade (Set)	5101986S

***Decal Group - Safety and Operation (North America Models) S/N: 4000812086 and Above***

REF NO	PART NO	QTY	DESCRIPTION
1	84008252	1	DECAL, MAIN SAFETY
2	5103184	1	DECAL, WARNING, HAND IN BELT, ENG ONLY -(Located on plate between hydraulic oil tanks)
3	7101665	2	DECAL, DANGER DO NOT OPERATE W/O DEFLECT
4	5104269	1	DECAL, SPANISH MANUAL, IGES, C-TICK
5	5100957	1	DECAL, HYDRAULIC OIL, 20W50 -(Located on frame cross bar)
6	5100342	1	DECAL, FUEL VALVE -(Models with two fuel tanks)
7	5100280	1	DECAL, THROTTLE CONTROL
8	5048970	1	DECAL, IGNITION SWITCH
9	5104268	2	DECAL, TRANSAXLE RELEASE, WB
10	5108119	1	DECAL, CUTTING HEIGHT, F60 & S50XT
11	5105152	1	DECAL, BELT & BLADE, F60Z

Not For Reproduction

# Deck Lift Group

Note: Unless noted otherwise, use the standard torque specifications

Mfg. No: 5901895

5304644

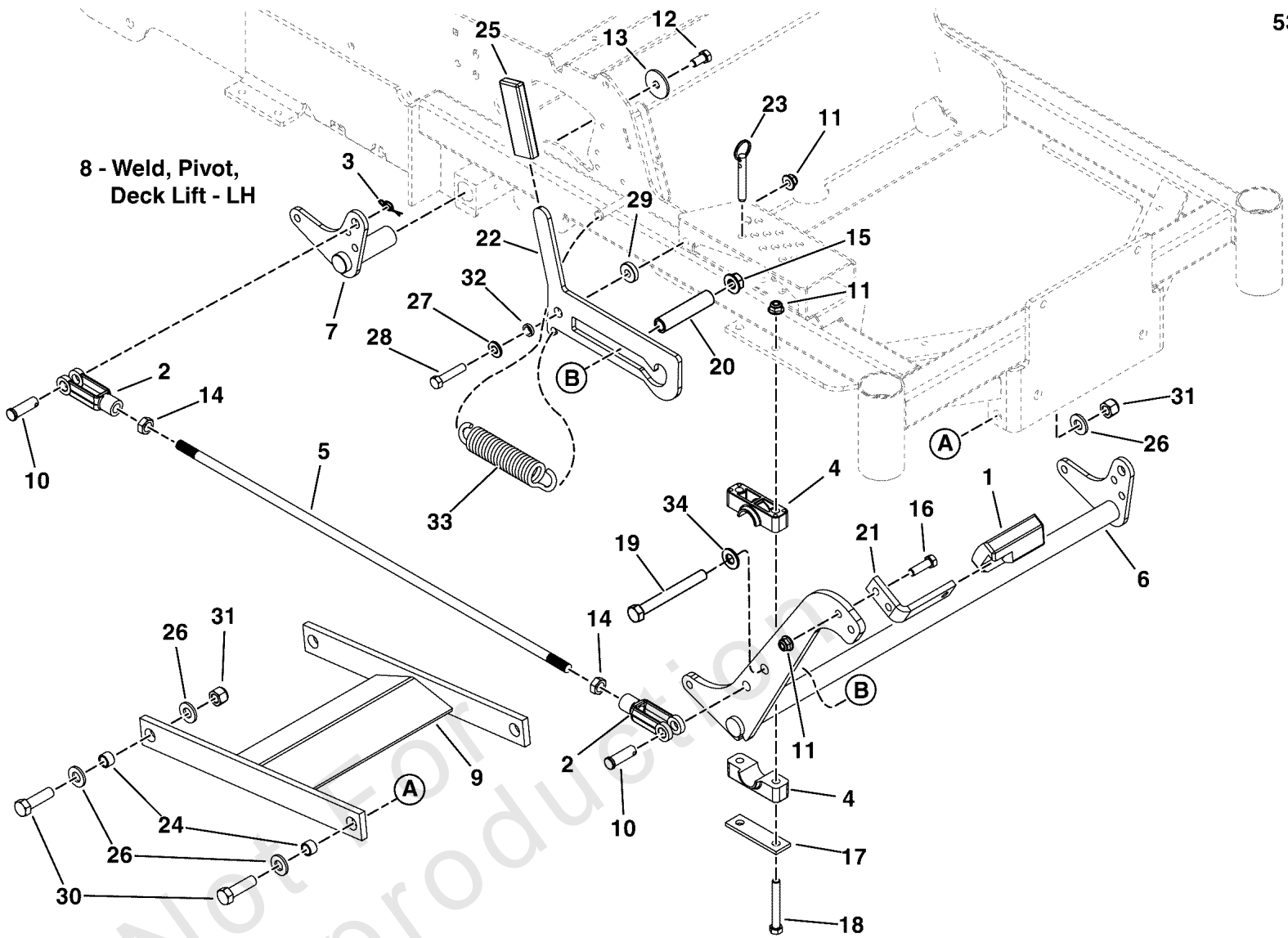



## Deck Lift Group

REF NO	PART NO	QTY	DESCRIPTION
1	5104262	1	PEDAL, Rubber
2	5023174	4	CLEVIS, 1/2-20, STEEL, CLEAR ZINC
3	7091594	4	COTTER PIN, 1/2" Self-Locking
4	5100634	4	PIVOT BLOCK, PLASTIC
5	5101117	2	ROD, DECK LIFT, SNAPPER PRO
6	5407892B	1	WELD, FRONT DECK PIVOT - RED
7	5402956A	1	WELD, PIVOT, DECK LIFT, RH - BLK
8	5402957A	1	WELD, PIVOT, DECK LIFT, LH - BLK
9	5415168A	1	WELD, PULLER BAR - BLK
10	5025328X12	4	PIN, CLEVIS, 1/2 X 1-1/2, PLATED
11	5025394	7	NUT, 3/8 - 16 HEX NYLOCK FLANGE
12	5025443	2	BOLT, 3/8-16 X 3/4, PLT W/PATCH
13	5100548	2	WASHER, .390 X 1.50 X .109, YZ
14	5025089	4	NUT, 1/2-20 Hex Jam
15	5025056	1	NUT, 1/2-13 HEX NYLON LOCK
16	5025013X10	2	BOLT, 3/8-16 X 1-1/4" GD5 CZ
17	5403925A	2	PLATE, PIVOT BLOCK SUPPORT - BLK
18	5025013X22	4	BOLT, 3/8-16 X 2-3/4" GD5 CZ
19	5025017X36	1	BOLT, 1/2-13 X 4-1/2" GD5 YZ
20	5102545	1	SPACER, .53 X .73 X 3.38, CZ
21	5061569A	1	PEDAL, FOOT - BLK
22	5406623A	1	PLATE, DECK TRANSPORT LEVER - BLK
23	5103021	1	HITCH PIN, 3/8 X 2-1/2, COTTERLESS, CZ
24	5020870	4	INSERT, Bearing
25	5025510	1	GRIP, FOAM, 1/4 X 1 X 4.1
26	5025440	8	WASHER, 1/2" GD9 YZ
27	5025293	1	WASHER, 3/8" GR. 9 FLAT
28	5025013X14	1	BOLT, 3/8-16 X 1-3/4" GD5 CZ
29	5044960	1	SPACER, .39 X 1.00 X .25, PM, CZ
30	5025018X14	4	BOLT, 1/2-20 X 1-3/4" GD8 CZ
31	5025098	4	NUT, Hex, Nylon Lock, 1/2-20
32	5041930	1	SPACER, .38 X .50 X .27, CZ
33	5102692	1	SPRING, EXTENTION, .50 OD X 4.12 FL
34	5025158	1	WASHER, 1/2 SAE

# Electrical Group - Kawasaki

Note: Unless noted otherwise, use the standard torque specifications

Mfg. No: 5901895

5304659

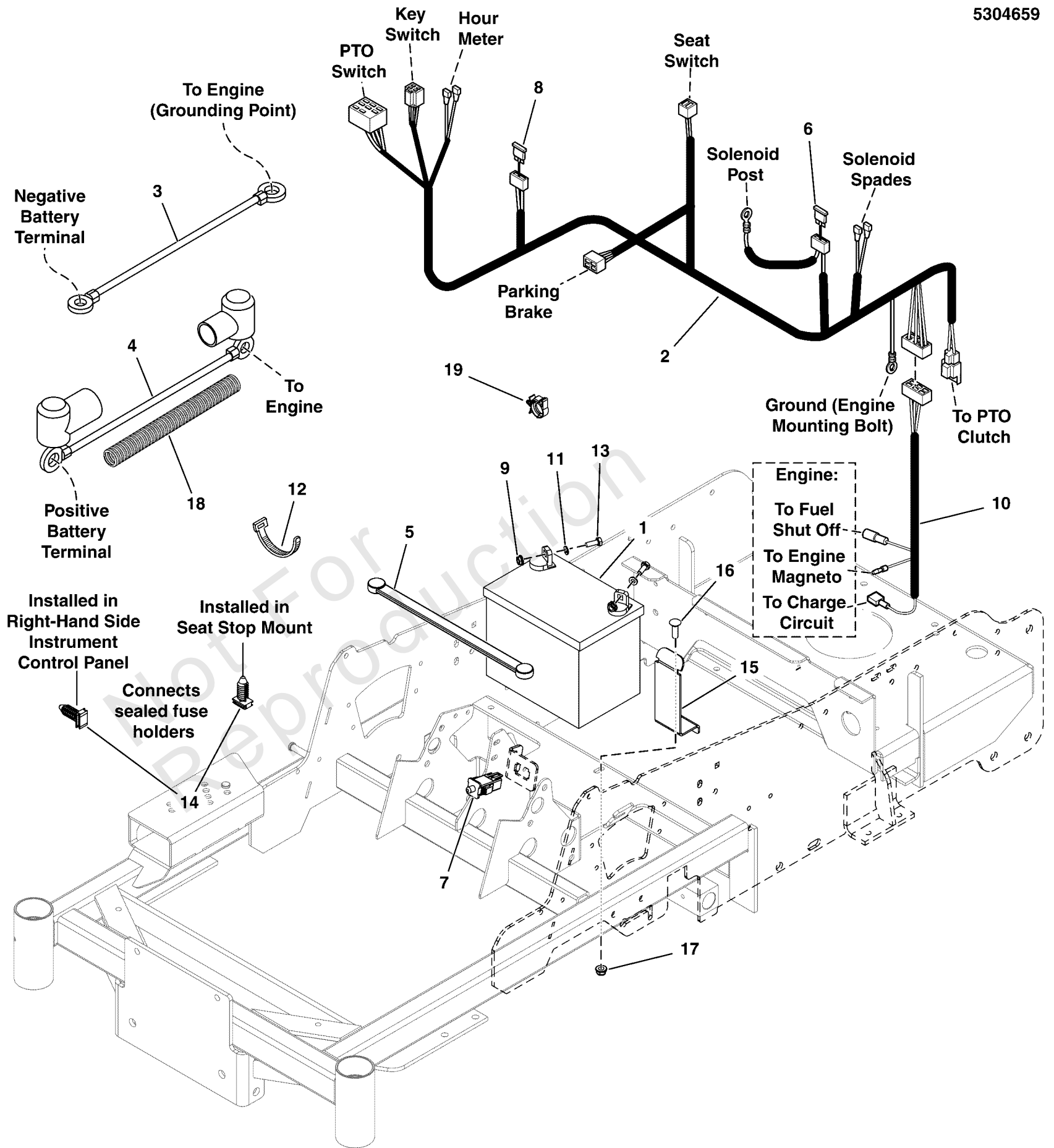

## Electrical Group - Kawasaki

REF NO	PART NO	QTY	DESCRIPTION
1	-----	1	BATTERY, 11U1L, 350 CCA
2	5415589	1	WIRE HARNESS, MAIN, PROSUMER, NO NEUTRAL -(S/N: 2017633638 & Below)
2	5416016	1	WIRE HARNESS, MAIN, SM, ZTR -(S/N: 2017633639 - 2017954955)
2	5105536		HARNESS, Wiring, Small ZTR -(S/N: 2017954956 & Above)
3	5045894	1	BATTERY CABLE, NEG, 35, 1/4-5/16
4	5021542	1	BATTERY CABLE, POS, 30, 1/4-5/16
5	1722009	1	STRAP, BATTERY, 14 LONG, Rubber
6	5021603	1	FUSE, ATO-20 (20 AMP)(SV) -(SV)
7	7022886	1	SWITCH, DP NO/NC SNAP-IN
8	5101935	1	FUSE, ATO-15 (15 AMP)(SV) -(SV)
9	5025126	4	NUT, 1/4-20 HEX SERR. FLANGE
10	5104811	1	WIRE HARNESS, JUMPER, KAWI
11	5025154	2	WASHER, 1/4 SAE
12	5021029	8	TIE, SELF-LOCKING, 12"
13	5025010X6	4	BOLT, 1/4"-20 X 3/4" GD5 YZ
14	5103761	2	FIR TREE MOUNT, PACKARD
15	5415727A	1	PLATE, HARNESS/BATTERY SUPPORT - BLK
16	5025145X8	1	BOLT, 5/16-18 X 1, CARRIAGE, GD5, CZ
17	5025392	1	NUT, 5/16-18 HEX NYLOCK FLANGE NUT
18	5050927X26	1	WIRE LOOM, 3/8 ID X 26 IN
19	5104705	1	ROSEBUD LOOM CLIP

# Electrical Schematic - Charging Circuit - S/N: 2017954955 & Below

Note: Unless noted otherwise, use the standard torque specifications

Mfg. No: 5901895

## 5416016 (5415589) MAIN WIRE HARNESS - KAWASAKI FX600V ENGINES

5416016B

(If internal schematic of the switch is not shown, the image of the switch represents the back view of the connector as it is connected to the switch.)

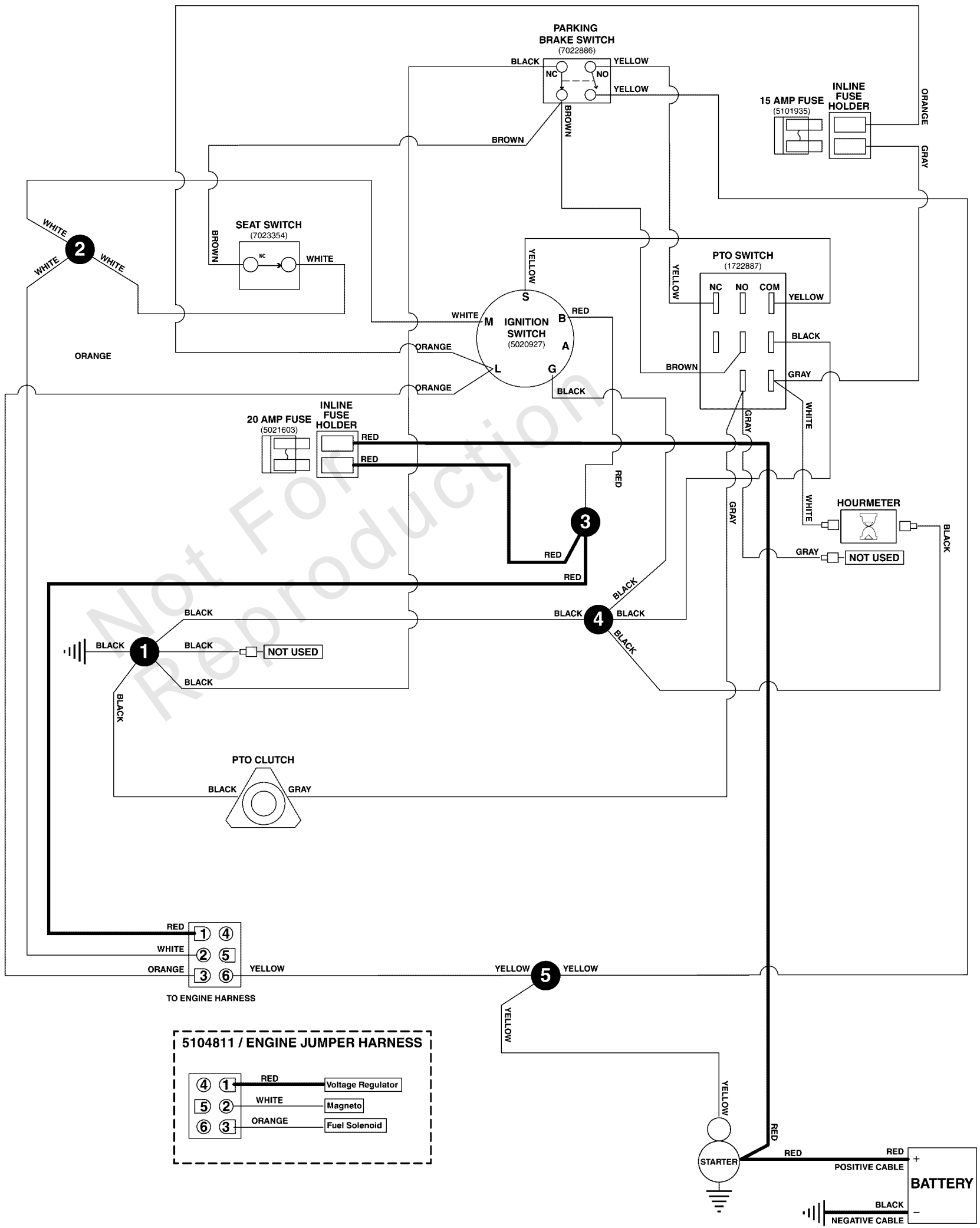

*Electrical Schematic - Charging Circuit - S/N: 2017954955 & Below*

---

REF NO	PART NO	QTY	DESCRIPTION
--------	---------	-----	-------------

---

Not For Reproduction

# Electrical Schematic - Charging Circuit - S/N: 2017954956 & Above

Note: Unless noted otherwise, use the standard torque specifications

Mfg. No: 5901895

## 5105536 MAIN WIRE HARNESS - KAWASAKI FX600V ENGINES

5105536E

(If internal schematic of the switch is not shown, the image of the switch represents the back view of the connector as it is connected to the switch.)

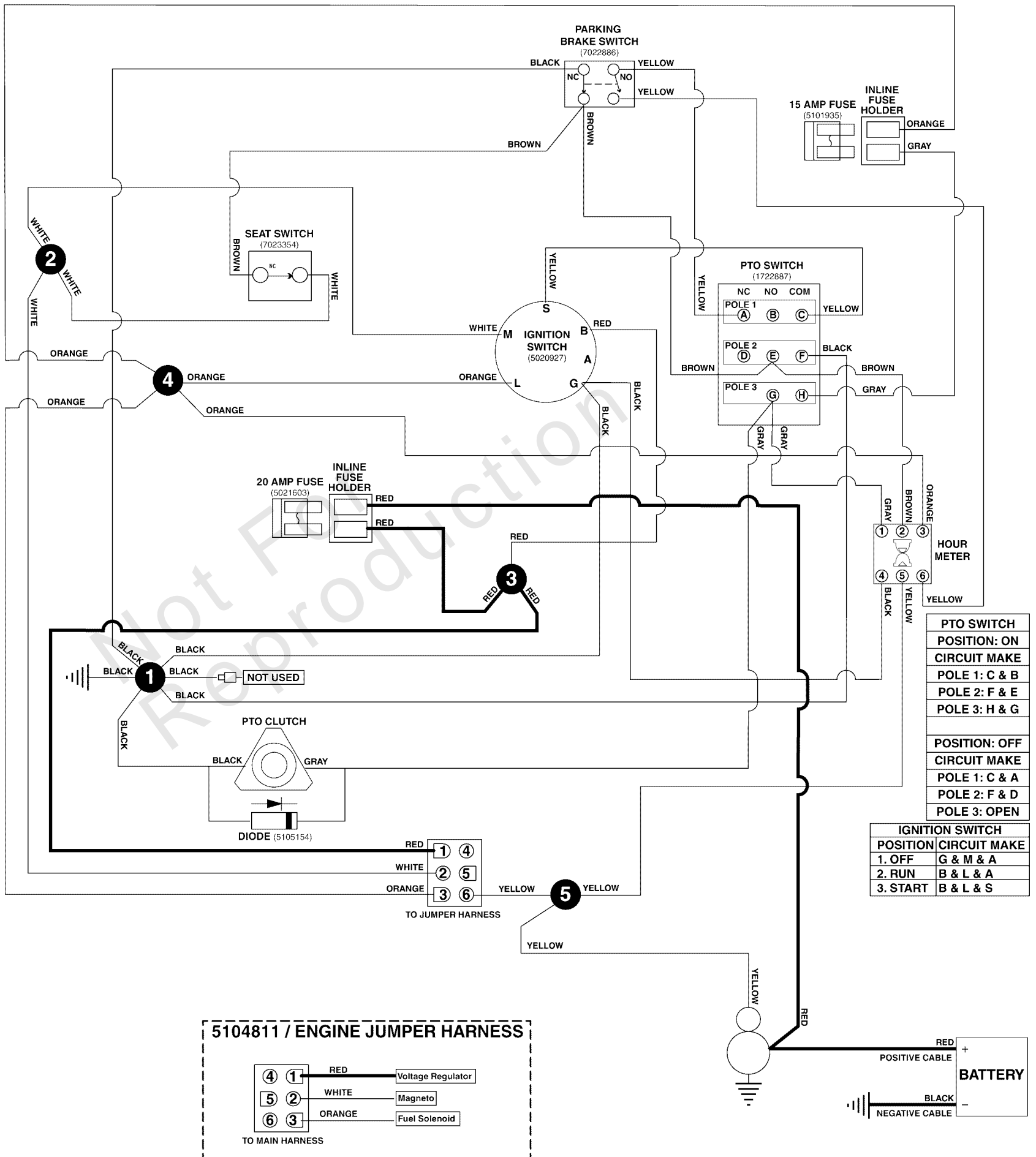

**Electrical Schematic - Charging Circuit - S/N: 2017954956 & Above**

---

REF NO	PART NO	QTY	DESCRIPTION
5105536	5105536	1	HARNESS, Wiring, Small ZTR
5104811	5104811	1	WIRE HARNESS, JUMPER, KAWI

Not For Reproduction

# Electrical Schematic - Cranking Circuit - S/N: 2017954955 & Below

Note: Unless noted otherwise, use the standard torque specifications

Mfg. No: 5901895

## 5416016 (5415589) MAIN WIRE HARNESS - KAWASAKI FX600V ENGINES

5416016B

(If internal schematic of the switch is not shown, the image of the switch represents the back view of the connector as it is connected to the switch.)

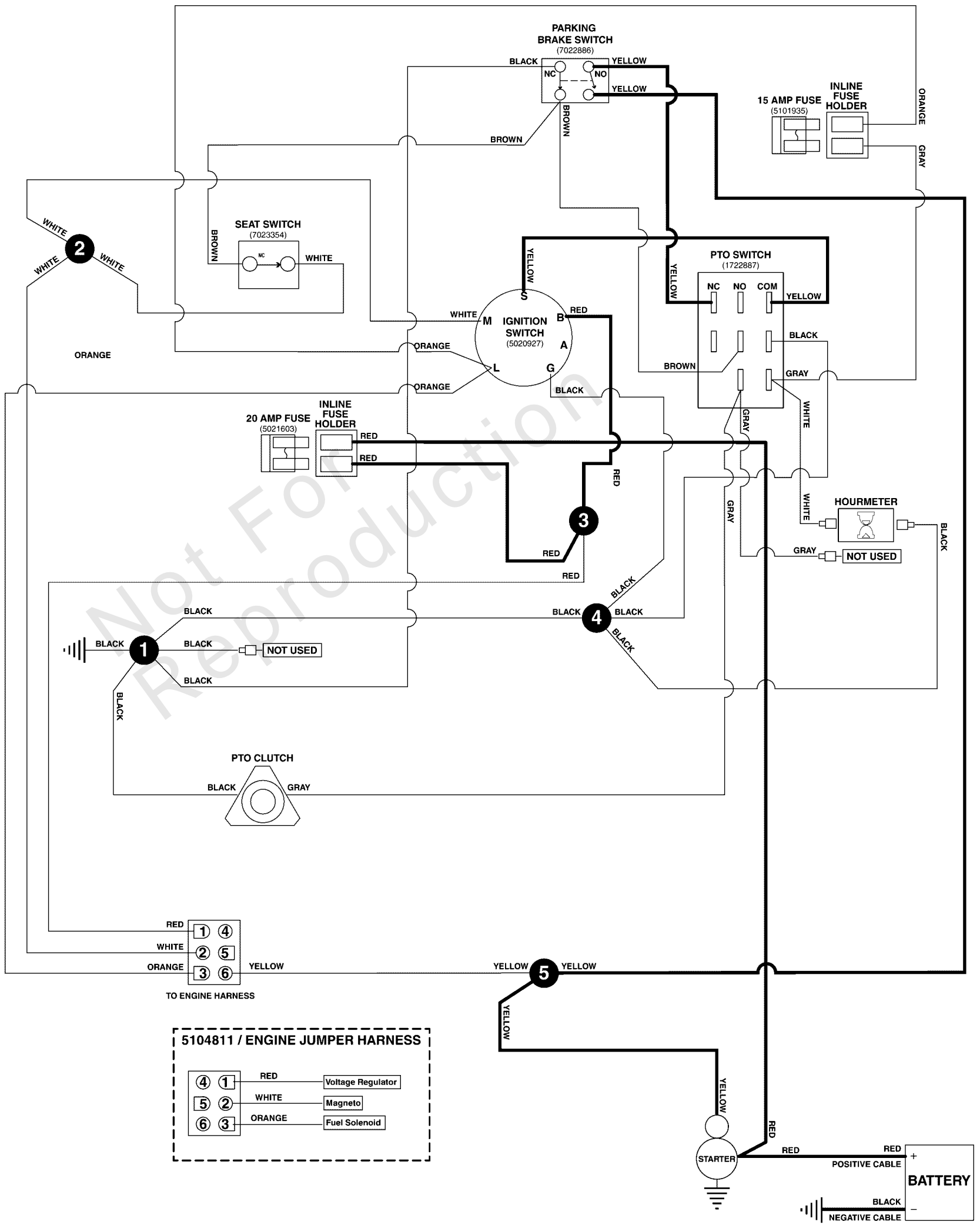



*Electrical Schematic - Cranking Circuit - S/N: 2017954955 & Below*

---

REF NO	PART NO	QTY	DESCRIPTION
--------	---------	-----	-------------

---

Not For Reproduction

# Electrical Schematic - Cranking Circuit - S/N: 2017954956 & Above

Note: Unless noted otherwise, use the standard torque specifications

Mfg. No: 5901895

## 5105536 MAIN WIRE HARNESS - KAWASAKI FX600V ENGINES

5105536E

(If internal schematic of the switch is not shown, the image of the switch represents the back view of the connector as it is connected to the switch.)

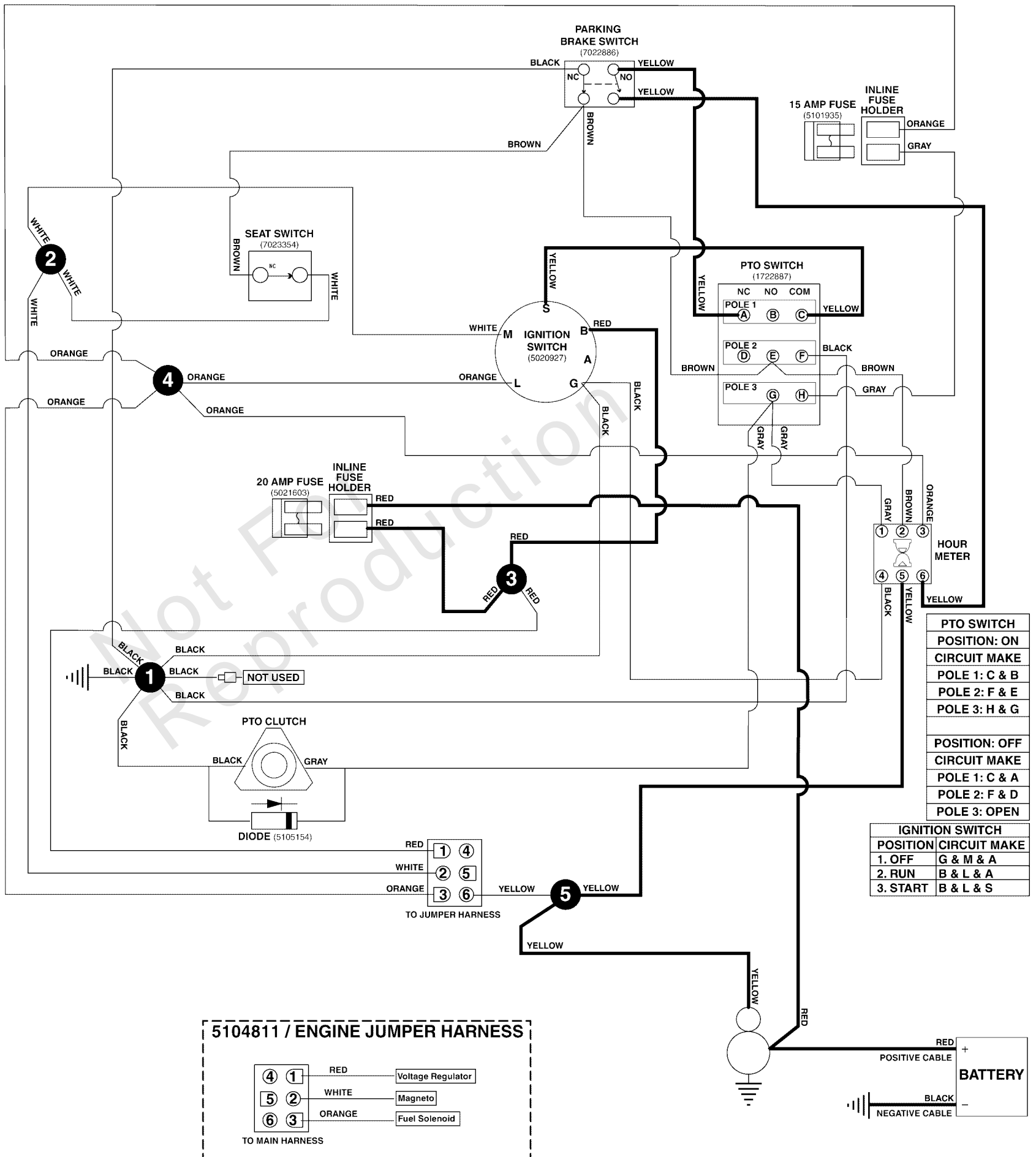

**Electrical Schematic - Cranking Circuit - S/N: 2017954956 & Above**

---

REF NO	PART NO	QTY	DESCRIPTION
5105536	5105536	1	HARNESS, Wiring, Small ZTR
5104811	5104811	1	WIRE HARNESS, JUMPER, KAWI

Not For Reproduction

# Electrical Schematic - Ign. Ground Circuit/Op Pres. - S/N: 2017954955 & Below

Note: Unless noted otherwise, use the standard torque specifications

Mfg. No: 5901895

## 5416016 (5415589) MAIN WIRE HARNESS - KAWASAKI FX600V ENGINES

5416016B

(If internal schematic of the switch is not shown, the image of the switch represents the back view of the connector as it is connected to the switch.)

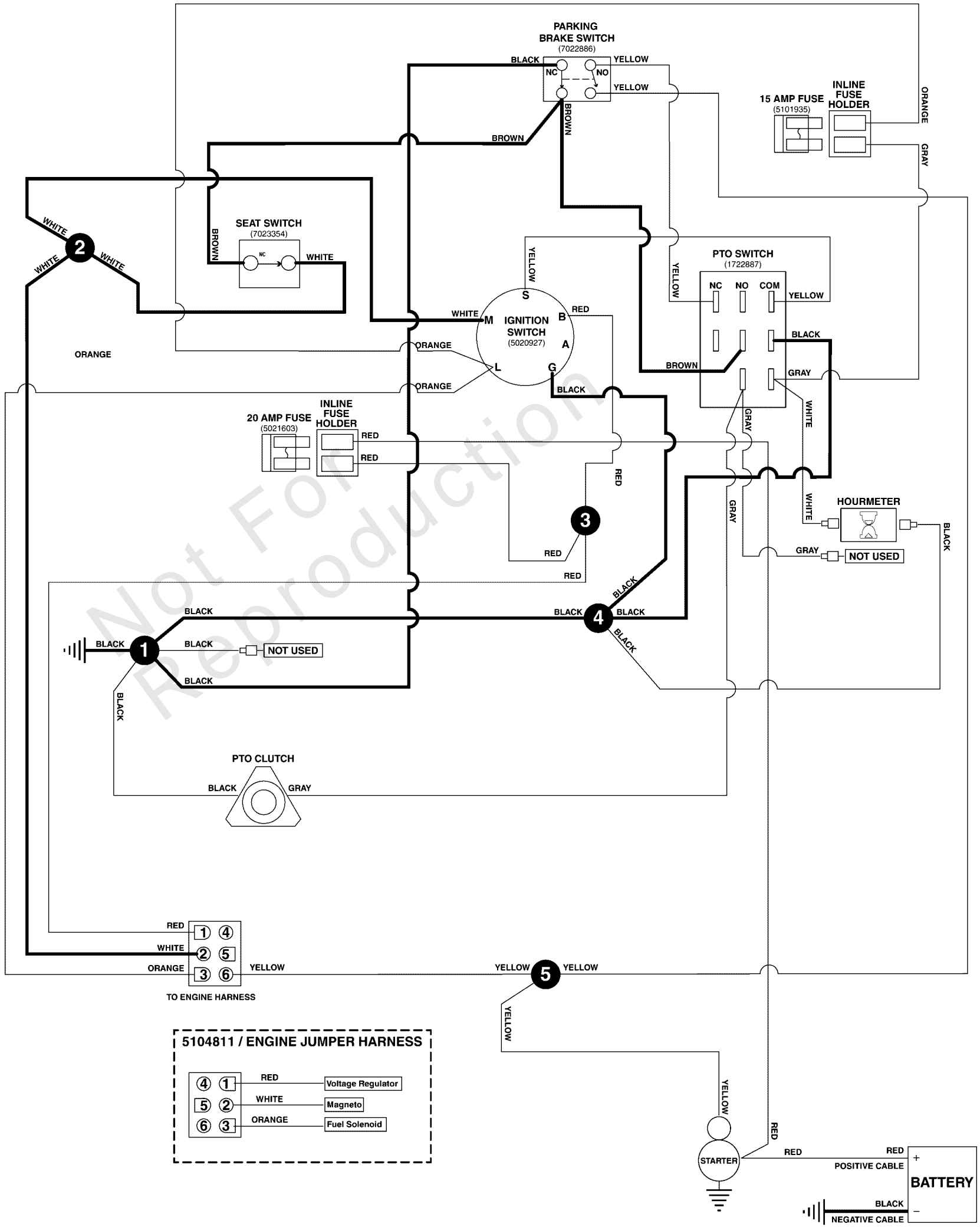

*Electrical Schematic - Ign. Ground Circuit/Op Pres. - S/N: 2017954955 & Below*

---

REF NO	PART NO	QTY	DESCRIPTION
--------	---------	-----	-------------

---

Not For Reproduction

# Electrical Schematic - Ign. Ground Circuit/Op. Pres. - S/N: 2017954956 & Above

Note: Unless noted otherwise, use the standard torque specifications

Mfg. No: 5901895

## 5105536 MAIN WIRE HARNESS - KAWASAKI FX600V ENGINES

5105536E

(If internal schematic of the switch is not shown, the image of the switch represents the back view of the connector as it is connected to the switch.)

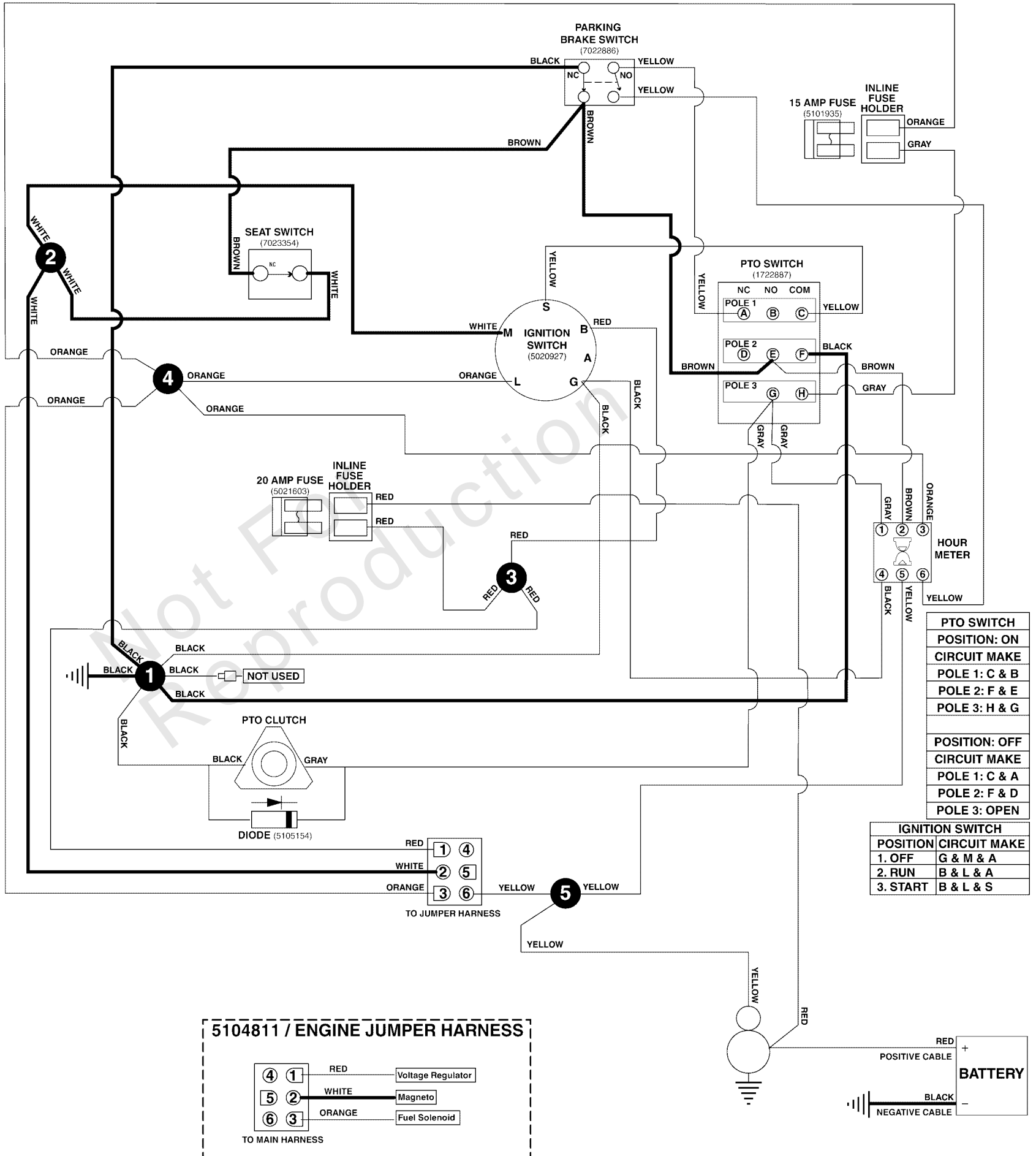

**Electrical Schematic - Ign. Ground Circuit/Op. Pres. - S/N: 2017954956 & Above**

REF NO	PART NO	QTY	DESCRIPTION
5105536	5105536	1	HARNESS, Wiring, Small ZTR
5104811	5104811	1	WIRE HARNESS, JUMPER, KAWI

Not For Reproduction

# Electrical Schematic - PTO Clutch Circuit - S/N: 2017954955 & Below

Note: Unless noted otherwise, use the standard torque specifications

Mfg. No: 5901895

## 5416016 (5415589) MAIN WIRE HARNESS - KAWASAKI FX600V ENGINES

5416016B

(If internal schematic of the switch is not shown, the image of the switch represents the back view of the connector as it is connected to the switch.)

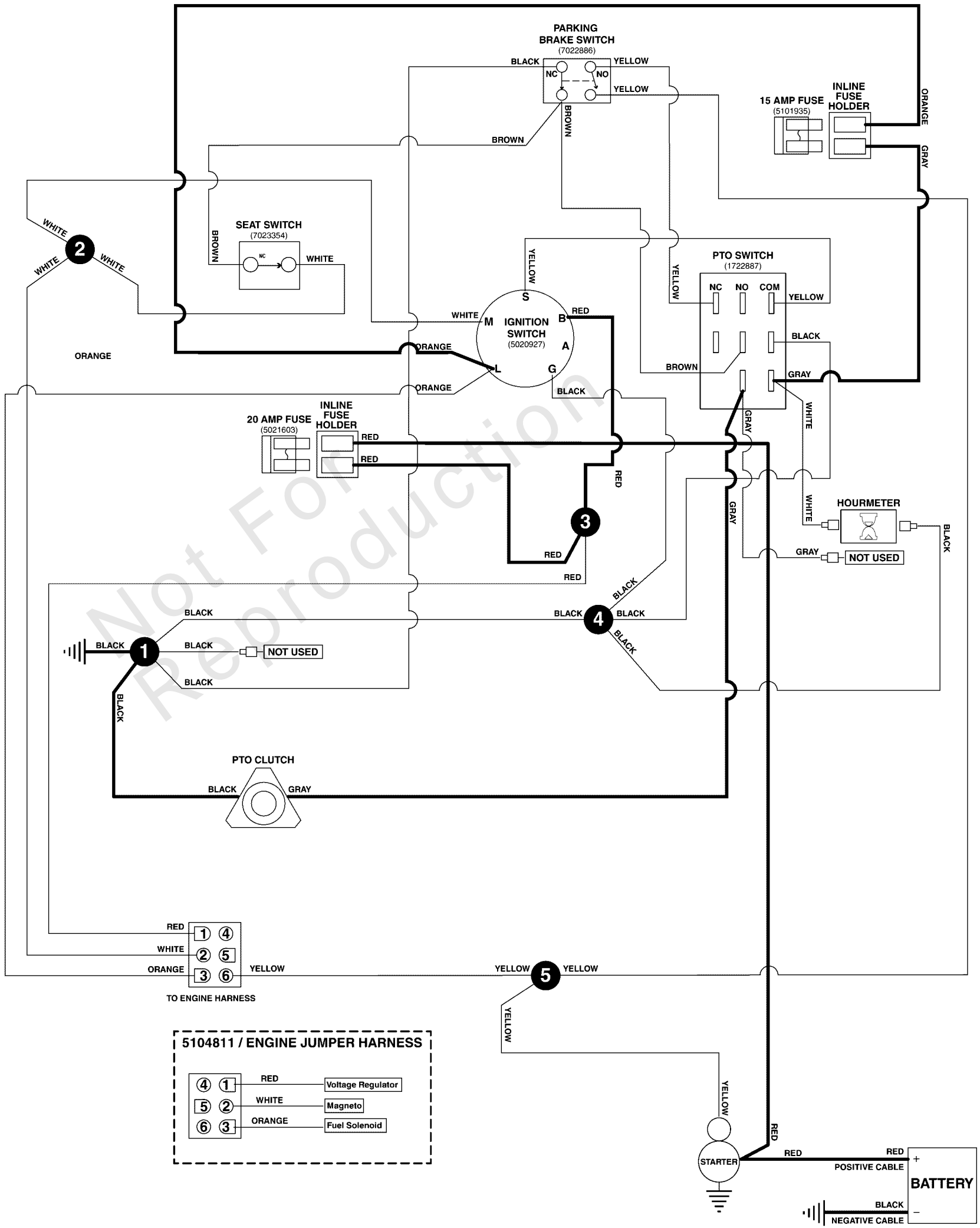



**Electrical Schematic - PTO Clutch Circuit - S/N: 2017954955 & Below**

---

REF NO	PART NO	QTY	DESCRIPTION
--------	---------	-----	-------------

---

Not For Reproduction

# Electrical Schematic - PTO Clutch Circuit - S/N: 2017954956 & Above

Note: Unless noted otherwise, use the standard torque specifications

Mfg. No: 5901895

## 5105536 MAIN WIRE HARNESS - KAWASAKI FX600V ENGINES

5105536E

(If internal schematic of the switch is not shown, the image of the switch represents the back view of the connector as it is connected to the switch.)

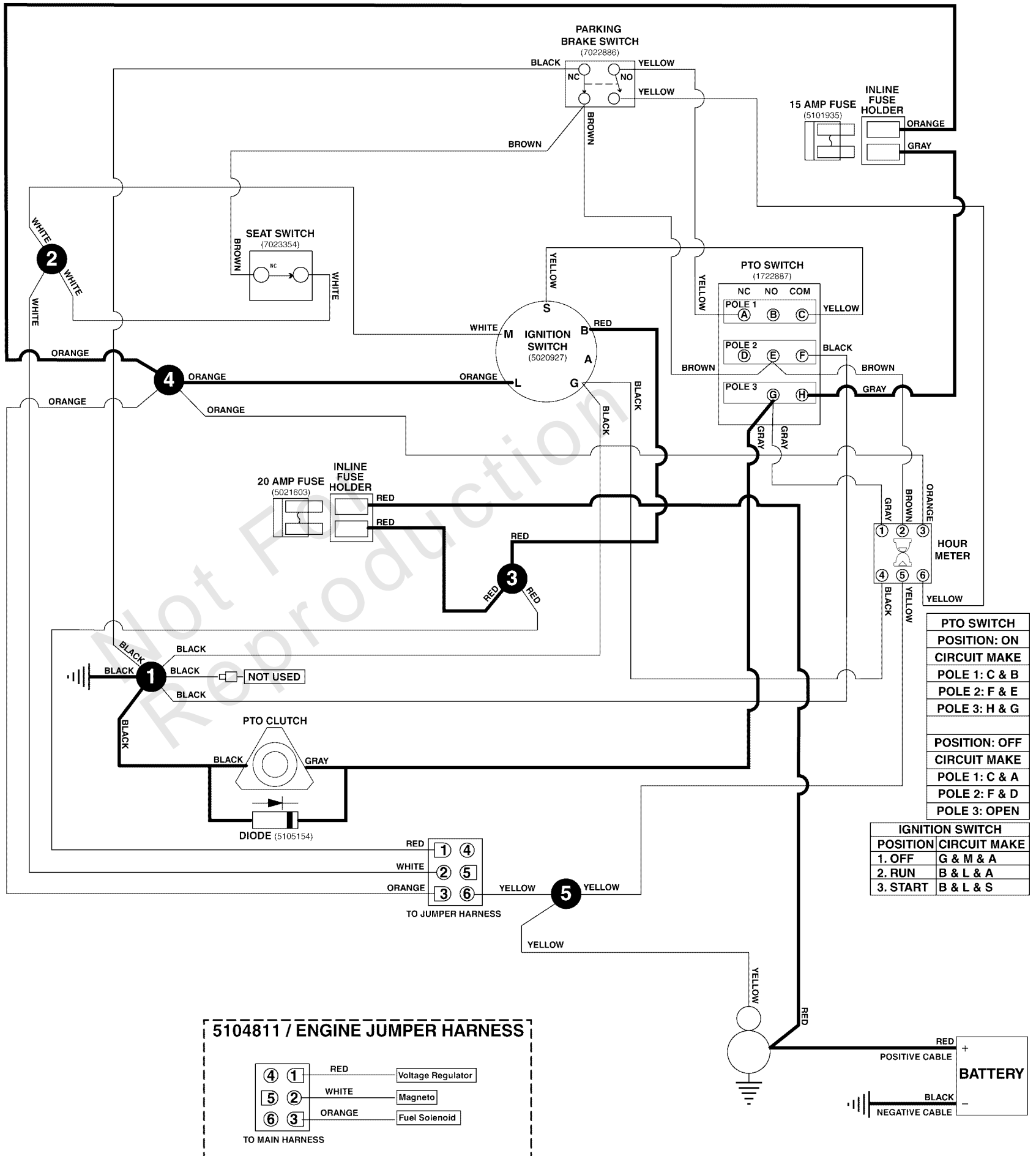

**Electrical Schematic - PTO Clutch Circuit - S/N: 2017954956 & Above**

REF NO	PART NO	QTY	DESCRIPTION
5105536	5105536	1	HARNESS, Wiring, Small ZTR
5104811	5104811	1	WIRE HARNESS, JUMPER, KAWI

Not For Reproduction

# Engine & PTO Group - Kawasaki

Note: Unless noted otherwise, use the standard torque specifications

Mfg. No: 5901895

5304871

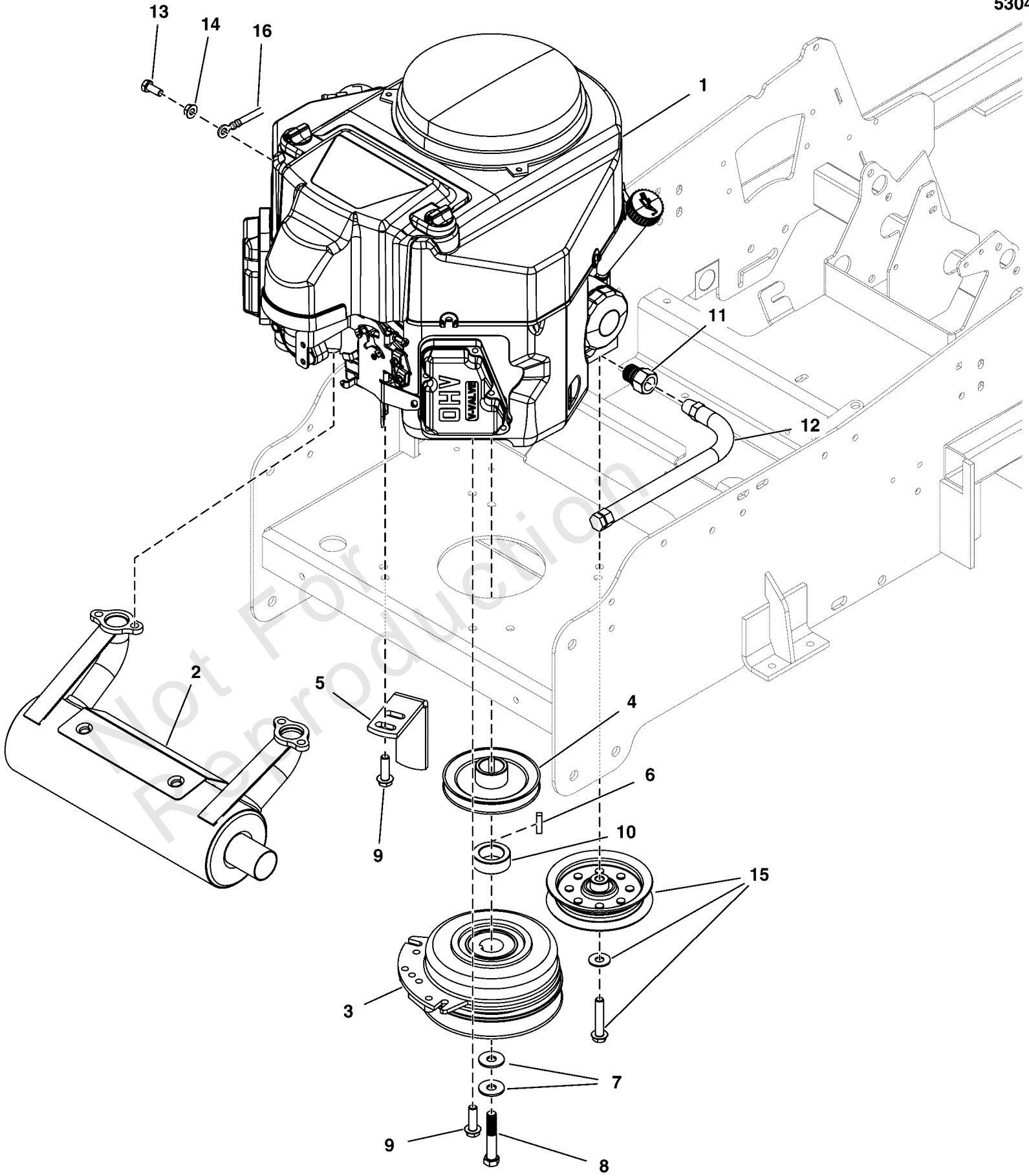

## Engine & PTO Group - Kawasaki

REF NO	PART NO	QTY	DESCRIPTION
1	FX600V-DS06-R	1	ENGINE, 19HP, KAWASAKI, FX600V
2	5102109	1	MUFFLER, (16-20HP), KAWASAKI S50X
3	5105087	1	CLUTCH, WARNER, 125 FT LBS, 1-1/8" BORE
4	5101338	1	PULLEY, PUMP DRIVE, 4.857 OB X 1-1/8
5	5404967A	1	ANCHOR, CLUTCH - BLK
6	5050407X8	1	KEY, 1/4 SQ X 1
7	5025585	2	BELLEVILLE WASHER, 1.1875 X .442 X .098
8	5102865	1	BOLT, CRANKSHAFT, 7/16 X 2-3/4, PATCH, CZ
9	5025532	3	BOLT, HEX FLG, SER, GD5 3/8-16 X 1-1/4" PACH CZ
10	5103892	1	SPACER, 1.13 X 1.75 X .75, CZ
11	5022234	1	ADAPTER, Oil Drain
12	5048681	1	HOSE, OIL DRAIN
13	5025249	1	BOLT, M8-1.25 X 20 MM GD 8.8
14	5025355	1	NUT, M8-1.25 Hex Serrated Flange
15	-----	1	SEE TRANSAXLE DRIVE GROUP
16	-----	1	SEE ELECTRICAL GROUP

Not For Reproduction

# Fuel Supply Hose, Tank Replacement Parts, and Evap Group

Note: Unless noted otherwise, use the standard torque specifications

Mfg. No: 5901895

5304637A  
5303790  
5303804  
5304954

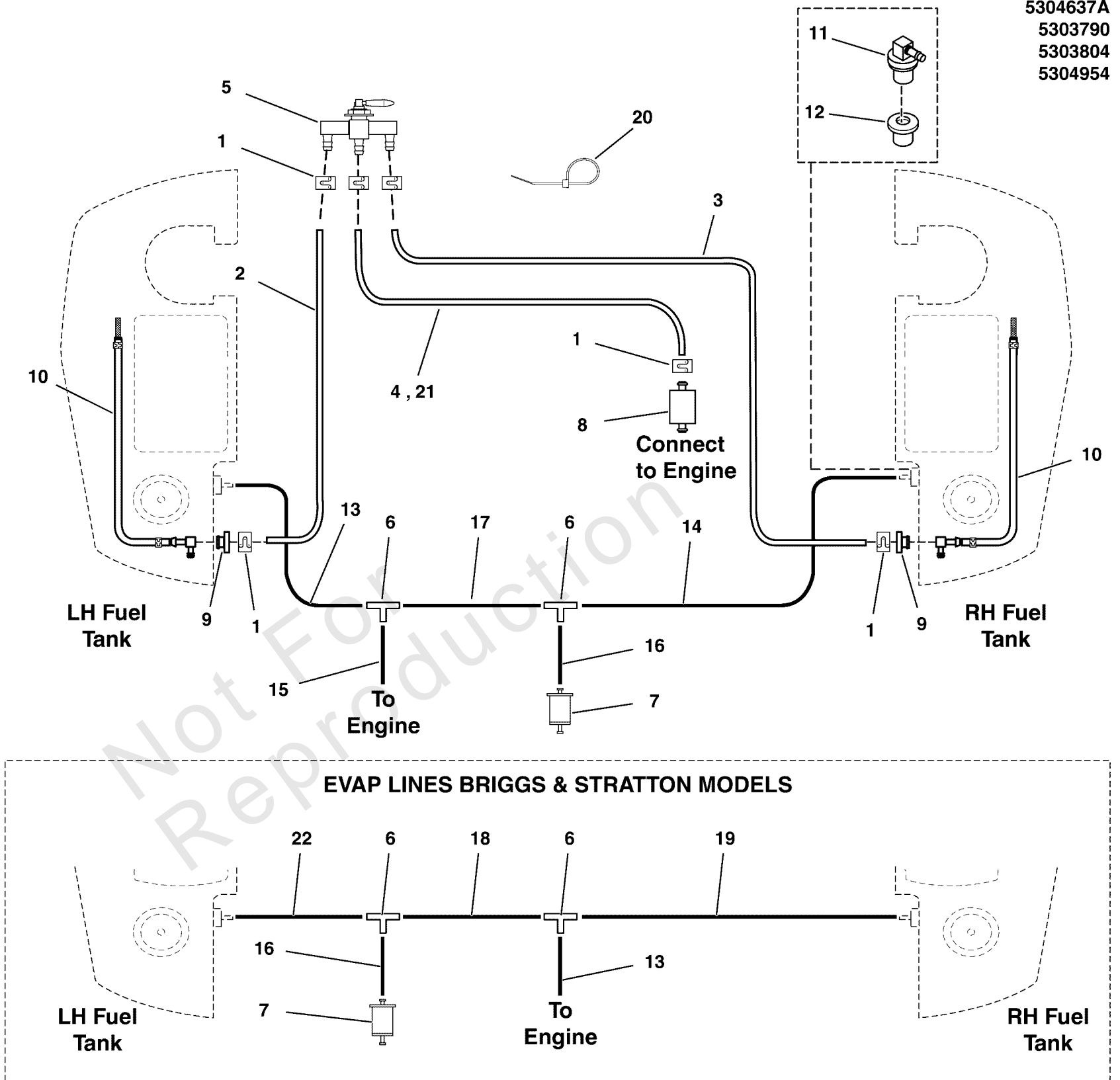

## Fuel Supply Hose, Tank Replacement Parts, and Evap Group

REF NO	PART NO	QTY	DESCRIPTION
1	93807	6	CLAMP, Hose
2	5050831X24	1	HOSE, FUEL, 1/4 IN, LW PRMTN, 24" LONG
3	5050831X26	1	HOSE, FUEL, 1/4 IN, LW PRMTN, 26" LONG
4	5050831X16	1	HOSE, FUEL, 1/4 IN, LW PRMTN, 16" LONG -(Briggs & Stratton Models)
5	-----	1	SEE FUEL TANK AND MOUNT GROUP
6	5103062	2	FITTING, 3/16" TEE, BARB TYPE, HDPE
7	80025019	1	FILTER, FUEL
8	5021178X3	1	FUEL FILTER (SV)
9	1726400	2	BUSHING-FUEL TANK RED RUBBER
10	5101402	2	PICKUP TUBE ASM, FUEL TANK, 23" (SV)
11	770046	2	REMOTE VENT ASSEMBLY
12	209043	2	GROMMET (SV)
13	7700552X12	1	HOSE, VAPOR, 5MM ID, 12.00 LG
14	7700552X21	1	HOSE, VAPOR, 5MM ID, 21.00 LG -(Kawasaki Models)
15	7700552X16P5	1	HOSE, VAPOR, 5MM ID, 16.50 LG -(Kawasaki Models)
16	7700552X2	1	HOSE, VAPOR, 5MM ID, 2.00 LG
17	7700552X17P5	1	HOSE, VAPOR, 5MM ID, 17.50 LG -(Kawasaki Models)
18	7700552X5	1	HOSE, VAPOR, 5MM ID, 5.00 LG -(Briggs & Stratton Models)
19	7700552X22	1	HOSE, VAPOR, 5MM ID, 22.00 LG -(Briggs & Stratton Models)
20	5021030	4	TIE, SELF-LOCKING, 6" -(Qty: 3 - Briggs & Stratton Models)
21	5050831X5	1	1/4" Fuel Line, 5" Long -(Kawasaki Models)
22	7700552X26	1	HOSE, VAPOR, 5MM ID, 26.00 LG -(Briggs & Stratton Models)

# Fuel Tank and Mount Group

Note: Unless noted otherwise, use the standard torque specifications

Mfg. No: 5901895

5304637

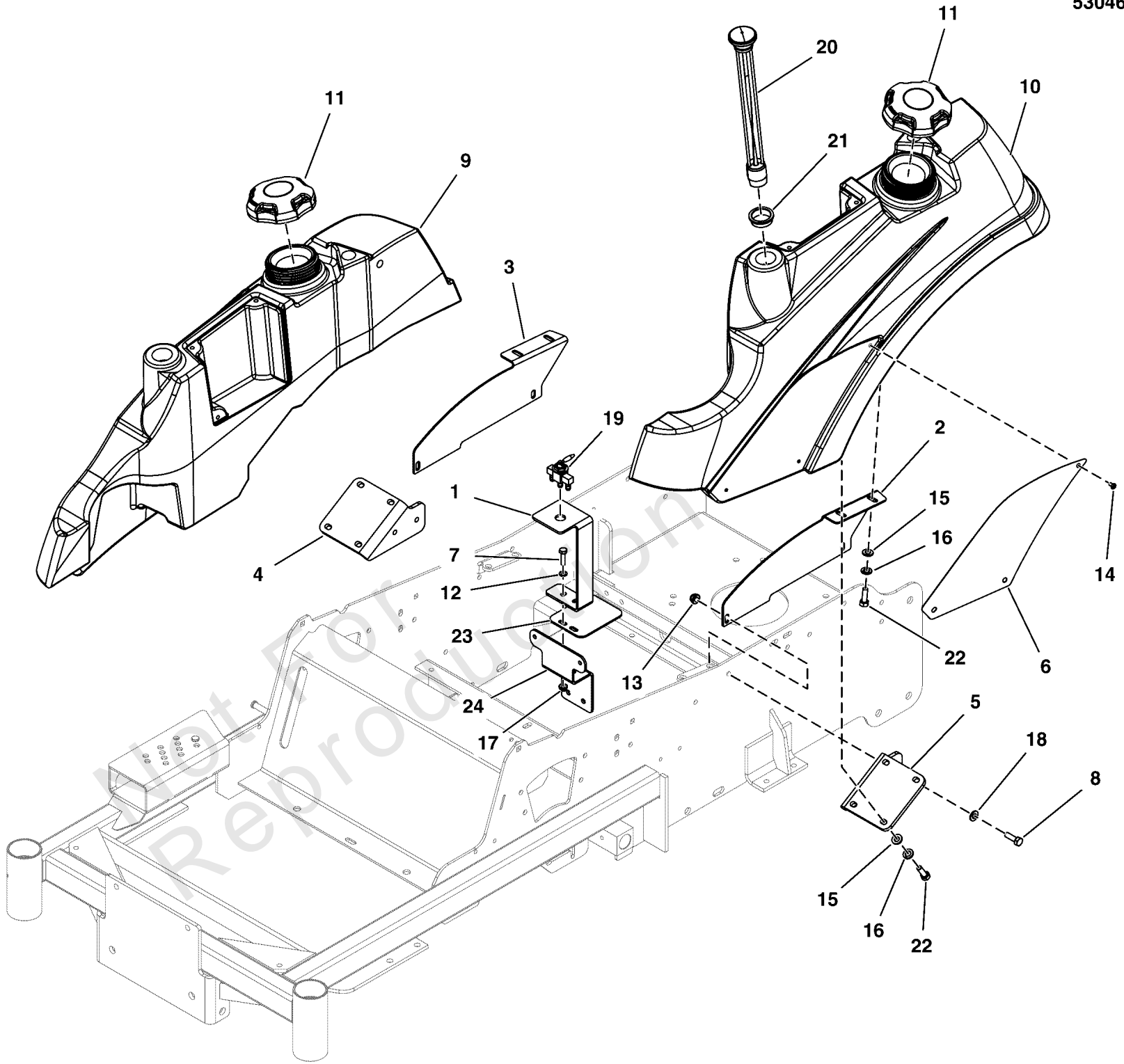



## Fuel Tank and Mount Group

REF NO	PART NO	QTY	DESCRIPTION
1	5415861A	1	BRACKET, FUEL VALVE, S50XT/F60Z - BLK
2	5415568B	1	PLATE, REAR TANK SUPPORT, LH -RED
3	5415567B	1	PLATE, REAR TANK SUPPORT, RH -RED
4	5415255A	1	PLATE, REAR TANK MOUNT, RH, F60Z- BLK
5	5415254A	1	PLATE, REAR TANK MOUNT, LH, F60Z - BLK
6	5400250B	2	PLATE, BADGE - RED
7	5025013X12	1	BOLT, 3/8-16 X 1-1/2" GD5 CZ
8	5025011X8	4	BOLT, 5/16-18 X 1 GD5 CZ
9	5104966	1	TANK, FUEL, F60Z, RH
10	5104965	1	TANK, FUEL, F60Z, LH
11	5103005	2	FUEL CAP, 3-1/2", MANAGED VENT OUT, 12"
12	5025394	1	NUT, 3/8-16 HEX NYLOCK FLANGE
13	5025392	6	NUT, 5/16-18 HEX NYLOCK FLANGE
14	5025386	6	SCREW, #10-24 X 3/8 ALLEN BHBZ
15	5025292	12	WASHER, 5/16 F436 FLAT
16	5025170	12	WASHER, 5/16 LOCK CZ
17	5025156	1	WASHER, 3/8 SAE
18	5025155	6	WASHER, 5/16" SAE
19	5023358	1	VALVE, FUEL SHUT-OFF, 11772
20	5022917	2	GAUGE, FUEL, 12 -(SV)
21	5022917X1	2	GROMMET, FUEL GAUGE -(SV)
22	5025011X6	12	BOLT, 5/16-18 X 3/4 GD5
23	-----	-	SEE ELECTRICAL GROUP -(Briggs & Stratton Models Only)
24	-----	-	SEE HYDRAULIC GROUP

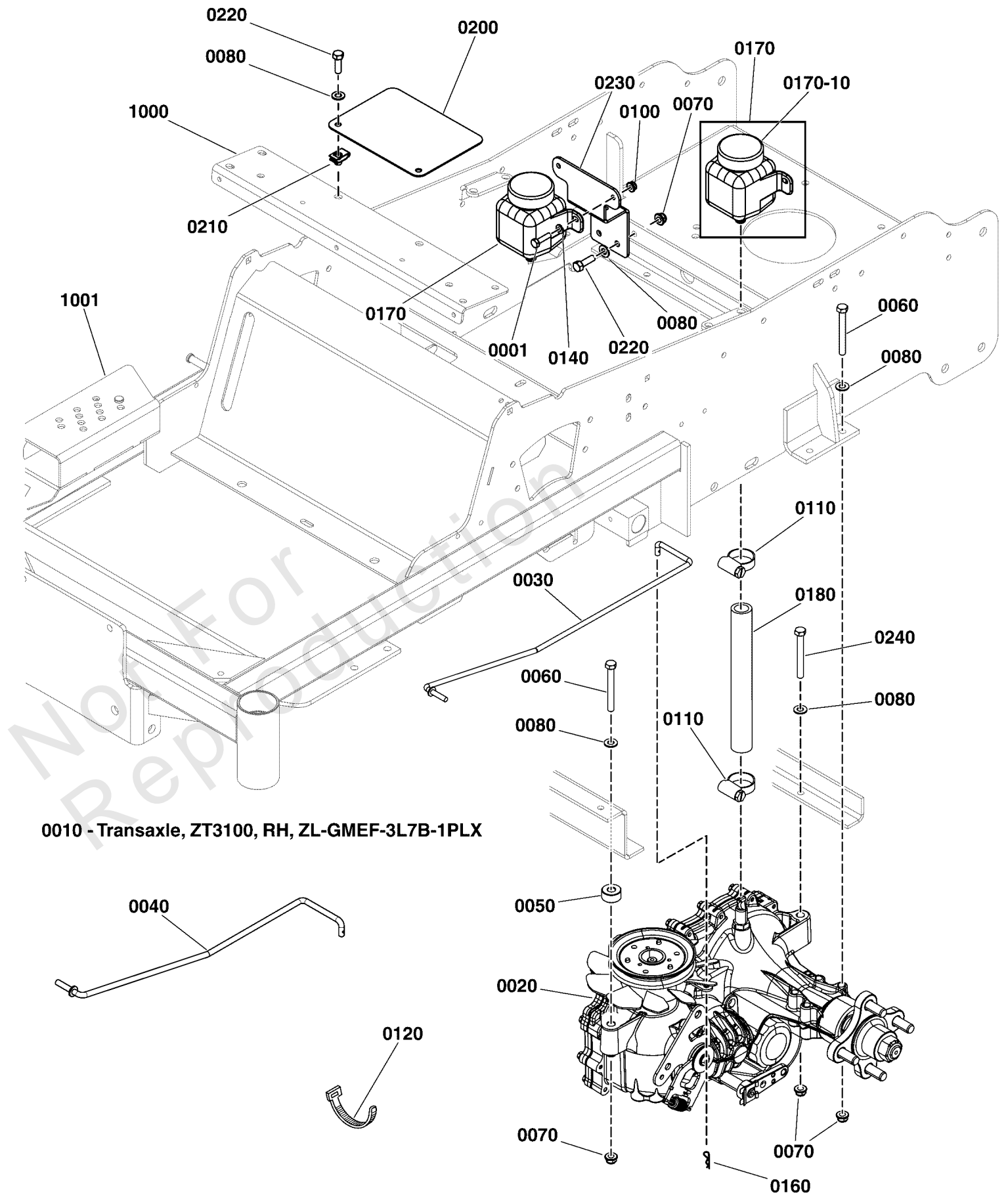

**0010 - Transaxle, ZT3100, RH, ZL-GMEF-3L7B-1PLX**

## Hydraulic Group

REF NO	PART NO	QTY	DESCRIPTION
0001	5025010X8	4	BOLT, 1/4-20 X 1" GD5 CZ
0010	5101024	1	TRANSAXLE, ZT3100, RH, ZL-GMEF-3L7B-1PLX -(Not illustrated)(S/N: 4001547047 and below)
0010	5109242	1	TRANSAXLE, ZT3100, RH, ZL-GMEF-3L7B-1PLX -(Not illustrated)(S/N: 4001547048 and above)
0020	5101025	1	TRANSAXLE, ZT3100, LH, ZL-KMEF-3L7C-1PLX -(S/N: 4001547047 and below)
0020	5109243	1	TRANSAXLE, ZT-3100, LH, ZL-KMEF-SL7C-1PLX -(S/N: 4001547048 and above)
0030	5101138	1	ROD, DUMP CONTROL, LH
0040	5101139	1	ROD, DUMP CONTROL, RH
0050	5046860	2	SPACER, .39 X 1.00 X .50, PM, CZ
0060	5025011X22	6	BOLT, 5/16-18 X 2-3/4, GD 5, YZ
0070	5025392	12	NUT, 5/16-18 HEX NYLOCK FLANGE NUT
0080	5025155	14	WASHER, 5/16" SAE
0100	5025391	4	NUT, 1/4-20 Hex Nylock Flange
0110	5025474	4	CLAMP, HOSE, .75 FREE DIA.
0120	5021029	2	TIE, SELF-LOCKING, 12"
0140	5025154	4	WASHER, 1/4 SAE
0160	5025211	1	PIN, HAIR, .0585 X 1-1/8, 1/4 EYE, YZ
0170	5100473	2	RESERVOIR, HYDRO OIL, 350 ML
0170-10	5100778X1	2	RESERVIOR CAP
0180	5050857X4P5	2	HOSE, 1/2" PUSH-ON, 4.50"
0200	5407997A	2	PLATE, BELT GUARD - BLK
0210	5022308	1	BODY CLIP, 5/16-18-7GA MATERIAL
0220	5025011X8	2	BOLT, 5/16-18 X 1" GRD5 YZ
0230	5415860A	6	PLATE, HYDRO BOTTLE MOUNT - BLK
0240	5025011X18	2	BOLT, 5/16-18 X 2-1/4" GD5 YZ
1000	-----	1	Refer to: Seat Mount & Floor Group
1001	-----	1	Refer to: Main Frame & Front Caster Group

# Instrument Control Panel Group

Note: Unless noted otherwise, use the standard torque specifications

Mfg. No: 5901895

5304638

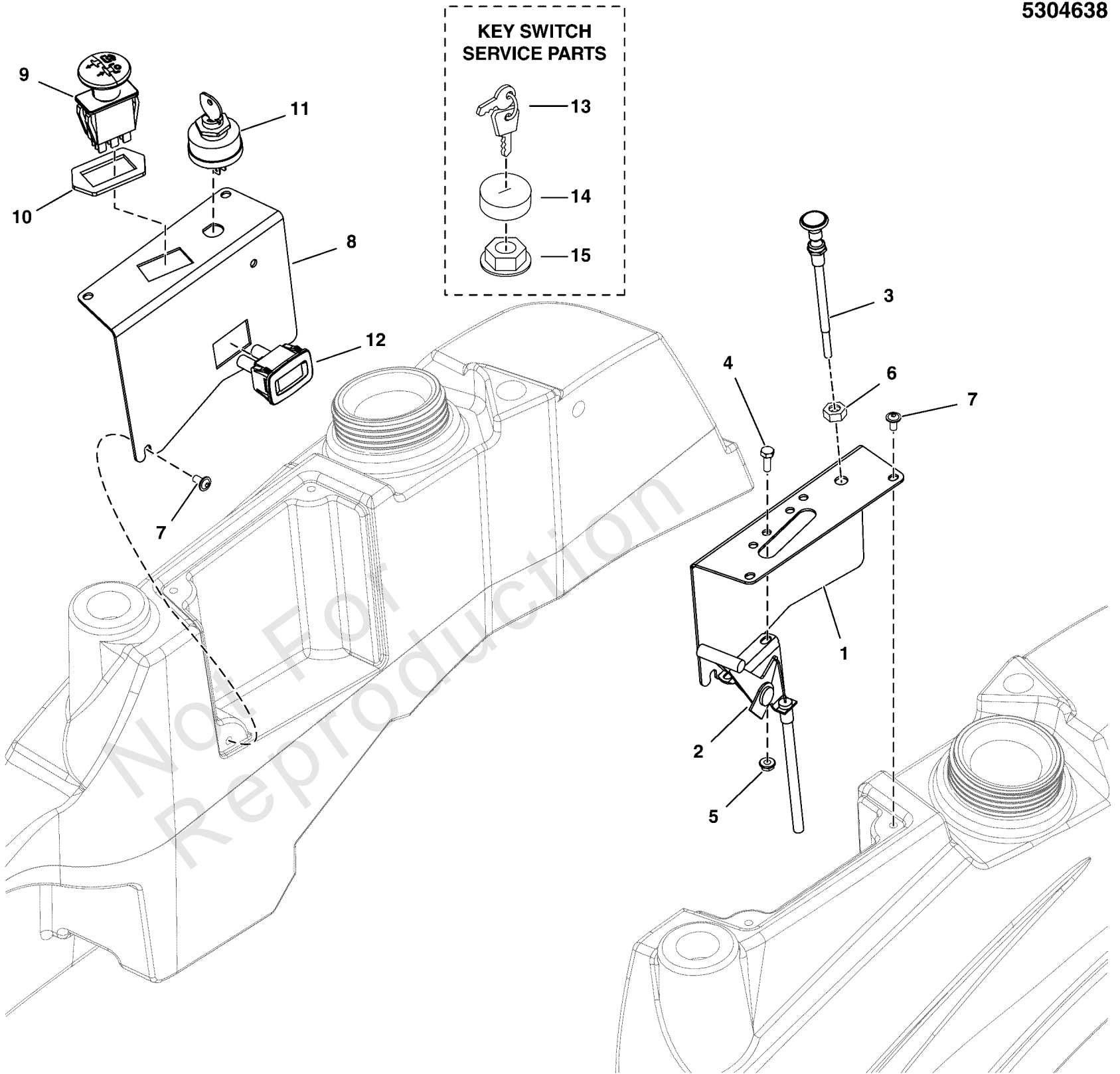

## Instrument Control Panel Group

REF NO	PART NO	QTY	DESCRIPTION
1	5415256A	1	PLATE, CONTROL PANEL, LH, F60Z - BLK
2	5105187	1	CABLE, THROTTLE CONTROL, 51"
3	5047779	1	CABLE, CHOKE CONTROL, 51" (Z)
4	-----	2	HHCS, 1/4-20 X 0.625, GR5, ZINC/CLEAR
5	5025391	2	NUT, 1/4-20 Hex Nylock Flange
6	5025309	1	NUT, 3/8-24 Hex Jam
7	5025299X4	6	SCREW, ALLEN HEAD 1/4-20X.500 ZINC PHOS
8	5415736A	1	CONTROL PANEL, RH, F60Z - BLK
9	1722887	1	SWITCH-PTO PUSH
10	5022222	1	RING, SWITCH RETAINER
11	5020927	1	SWITCH, IGNITION, 6 POST -(Includes Ref # 13 - 15)
12	84008768	1	HOURMETER
13	5022789	1	KEY, IGNITION MOLDED SET
14	5022790	1	COVER, PLASTIC, SNAP ON
15	5022791	1	PLASTIC NUT

Not For Reproduction

# Main Frame & Front Casters Group

Note: Unless noted otherwise, use the standard torque specifications

Mfg. No: 5901895

5304652  
5304845  
5304847

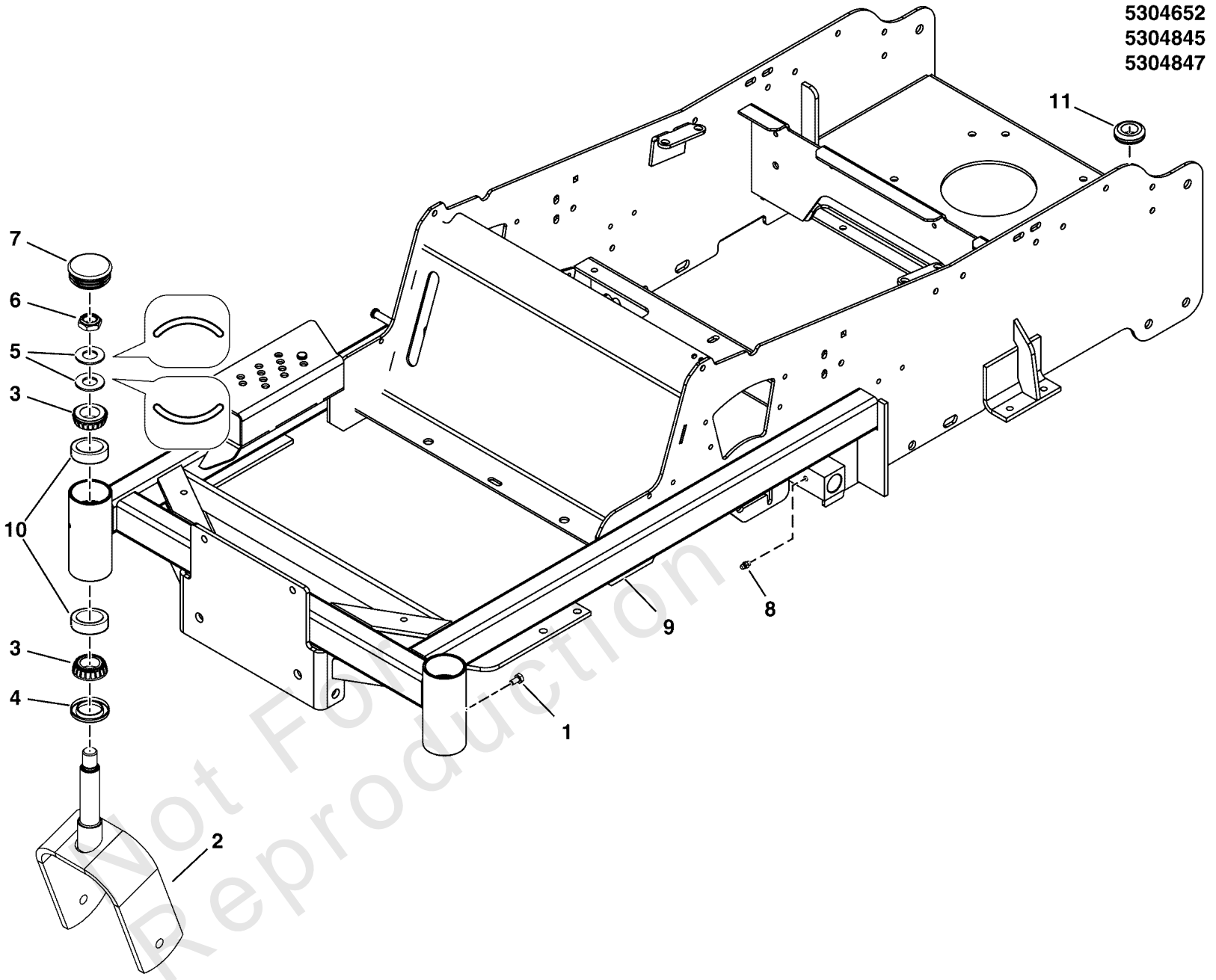

## Main Frame & Front Casters Group

REF NO	PART NO	QTY	DESCRIPTION
1	5025457	2	BOLT, 1/4-28 X 1/2, GD5 YZ
2	5402539B	2	WELD, CASTER YOKE - RED
3	5020884	4	BEARING, TAPERED ROLLER, 1"
4	5021072	2	SEAL, GREASE
5	5025449	4	WASHER, BELLEVILLE - 1.500 X .755
6	5025448	2	NUT, 3/4-16, HEX JAM NYLON LOCK
7	5109845	2	CAP, GREASE, LOW PROFILE
8	5020095	2	GREASE FITTING, 1/4-28 Straight
9	-----	1	WELD, MAIN FRAME, 36" - RED - * If frame is damaged, call 1-800-933-6175 ext. 709
10	5020883	2	CUP, BEARING (SV)
11	5021379	1	GROMMET, 7/8"

Not For Reproduction

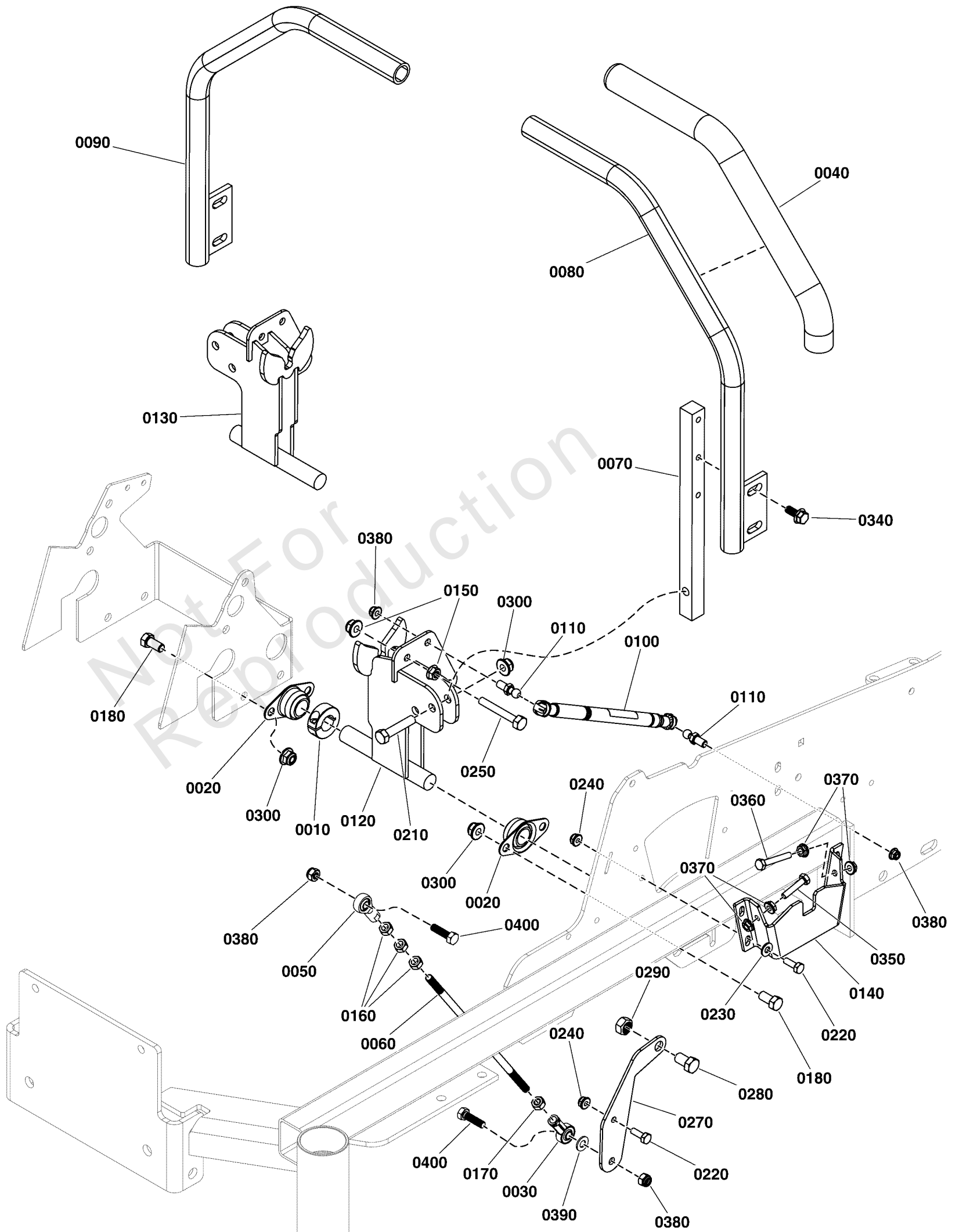



## Motion Control Group

REF NO	PART NO	QTY	DESCRIPTION
0010	5010114	2	COLLAR, 3/4" Split
0020	5021098	4	BEARING, BRONZE FLANGE, 3/4"
0030	5104579	2	BALL JOINT 5/16-24 LH FEMALE STAMPED STL
0040	5104722	2	GRIP, FOAM, 1" ID, 16" LONG
0050	5104578	2	BALL JOINT 5/16-24 RH FEMALE STAMPED STL
0060	5046420	2	ROD, HYDRO LINKAGE, CZ
0070	5103106A	2	MOUNT, CONTROL ARM - BLK
0080	5414429A	1	WELD,HANDLE MOTION CNTRL,17.0,1.0,LH,BLK
0090	5414430A	1	WELD, HANDLE MOTION CNTRL,17.0,1.0,RH,BLK
0100	5100940	2	DAMPENER, CONTROL,#(P6709/P3610)
0110	5100941	4	BALL STUD, 5/16 X .50,# PC-477-2)
0120	5416905A	1	WELD, MOTION CONTROL, LH - BLK
0130	5416906AYP	1	WELD, MOTION CONTROL, RH - BLK
0140	5415633AYP	2	PLATE, Neutral Box
0150	5025127	6	NUT, 5/16-18 HEX SERRATED FLANGE (SMALL)
0160	5025033	6	NUT, Hex, 5/16-24
0170	5023212	2	NUT, 5/16-24 HEX, LH
0180	5025013X6	8	BOLT, 3/8-16 X 3/4" GD5 CZ
0210	5025013X14	4	BOLT, 3/8-16 X 1-3/4" GD5 CZ
0220	5025010X6	10	BOLT, 1/4"-20 X 3/4" GD5 YZ
0230	5025154	8	WASHER, 1/4 SAE
0240	5025391	10	NUT, 1/4-20 Hex Nylock Flange
0250	5025055X18	2	BOLT, 5/16-18 X 2-1/4 TFL, GD5 YZ
0270	5402910A	2	PLATE, CONTROL LINK, TRANSAXLE - BLK
0280	5025015X6	2	BOLT, 7/16-14 X 3/4, GD 5 YZ
0290	5025044	2	NUT, 7/16-14 HEX TOP LOCK
0300	5025394	12	NUT, 3/8 - 16 HEX NYLOCK FLANGE
0340	80003531	4	SCREW, 5/16-18x0.750, GR5, WHIZ-LOCK, ZC
0350	5025068X10	2	BOLT, 1/4-20 X 1-1/4 GD5 TFL
0360	5025068X14	2	HEX BOLT, 1/4-20 X 1-3/4 GD 5, TFL
0370	5025126	8	NUT, 1/4-20 HEX SERR. FLANGE
0380	5025057	4	NUT, Hex, Nylon Locking, 5/16-18
0390	5025156	2	WASHER, 3/8 SAE
0400	5025011X9	4	BOLT, 5/16-18 X 1-1/8 GD5 CZ

# Parking Brake Group

Note: Unless noted otherwise, use the standard torque specifications

Mfg. No: 5901895

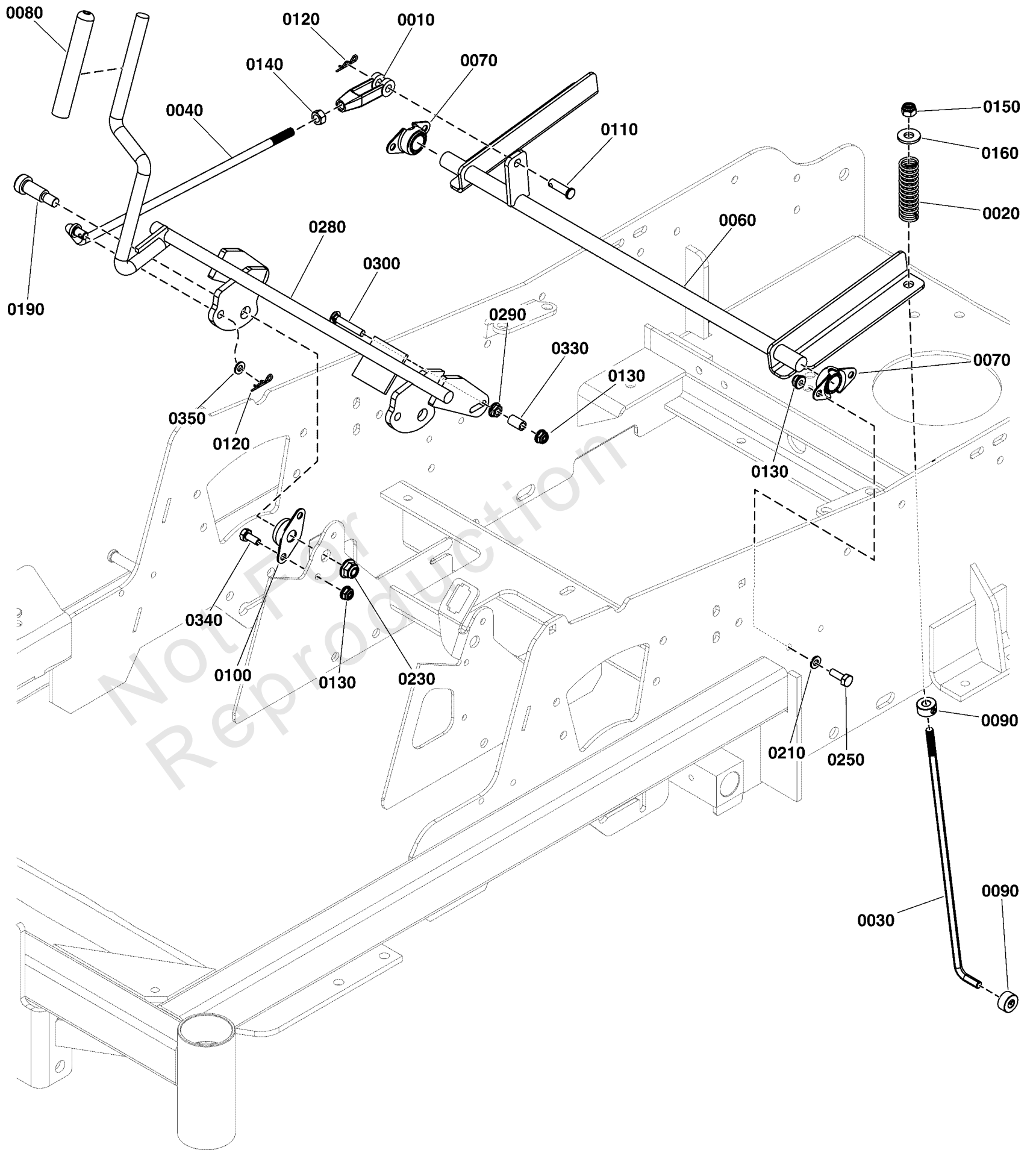

## Parking Brake Group

REF NO	PART NO	QTY	DESCRIPTION
0010	5023323	1	CLEVIS, 5/16-24, STEEL, CLEAR ZINC
0020	5021102	2	SPRING-COMP, .594ID X 2.68LG X .080WR
0030	5101058	2	ROD, BRAKE CTRL, LOWER - CONZ
0040	5104641	1	ROD, PARKING BRAKE, W35, UPPER
0060	5415462AYP	1	SHAFT, Brake
0070	5104270	2	BEARING, 5/8" FLANGED, PLASTIC BALL
0080	5021880	1	GRIP, FOAM, .475 X 4.35 X .095
0090	5020047	4	COLLAR, 5/16" Set
0100	5101123	2	BEARING, 1/2 FLANGED, PLASTIC BALL
0110	5025213X8	1	PIN, CLEVIS, 5/16 X 1, PLATED
0120	5025211	2	PIN, HAIR, .0585 X 1-1/8, 1/4 EYE, YZ
0130	5025391	10	NUT, 1/4-20 Hex Nylock Flange
0140	5025033	1	NUT, Hex, 5/16-24
0150	5025045	2	NUT, 5/16-24 HEX NYLON LOCK
0160	5025337	2	WASHER, 5/16" USS
0190	5025223	2	Bolt, 3/8-16 - 112" Dia. x 1" Shoulder
0210	5025154	4	WASHER, 1/4 SAE
0230	5025394	2	NUT, 3/8 - 16 HEX NYLOCK FLANGE
0250	5025010X6	4	BOLT, 1/4"-20 X 3/4" GD5 YZ
0280	5415410AYP	1	LEVER, Brake
0290	5025126	2	NUT, 1/4-20 HEX SERR. FLANGE
0300	80003564	2	BOLT, 1/4-20 X 1.500, GR5, SQ, ZINC/CLEAR
0330	5041483	2	SPACER, .52 X .38 X .63, CZ
0340	-----	4	HHCS, 1/4-20 X 0.625, GR5, ZINC/CLEAR
0350	5025155	1	WASHER, 5/16" SAE

# Rear Bumper Group

Note: Unless noted otherwise, use the standard torque specifications

Mfg. No: 5901895

5304635

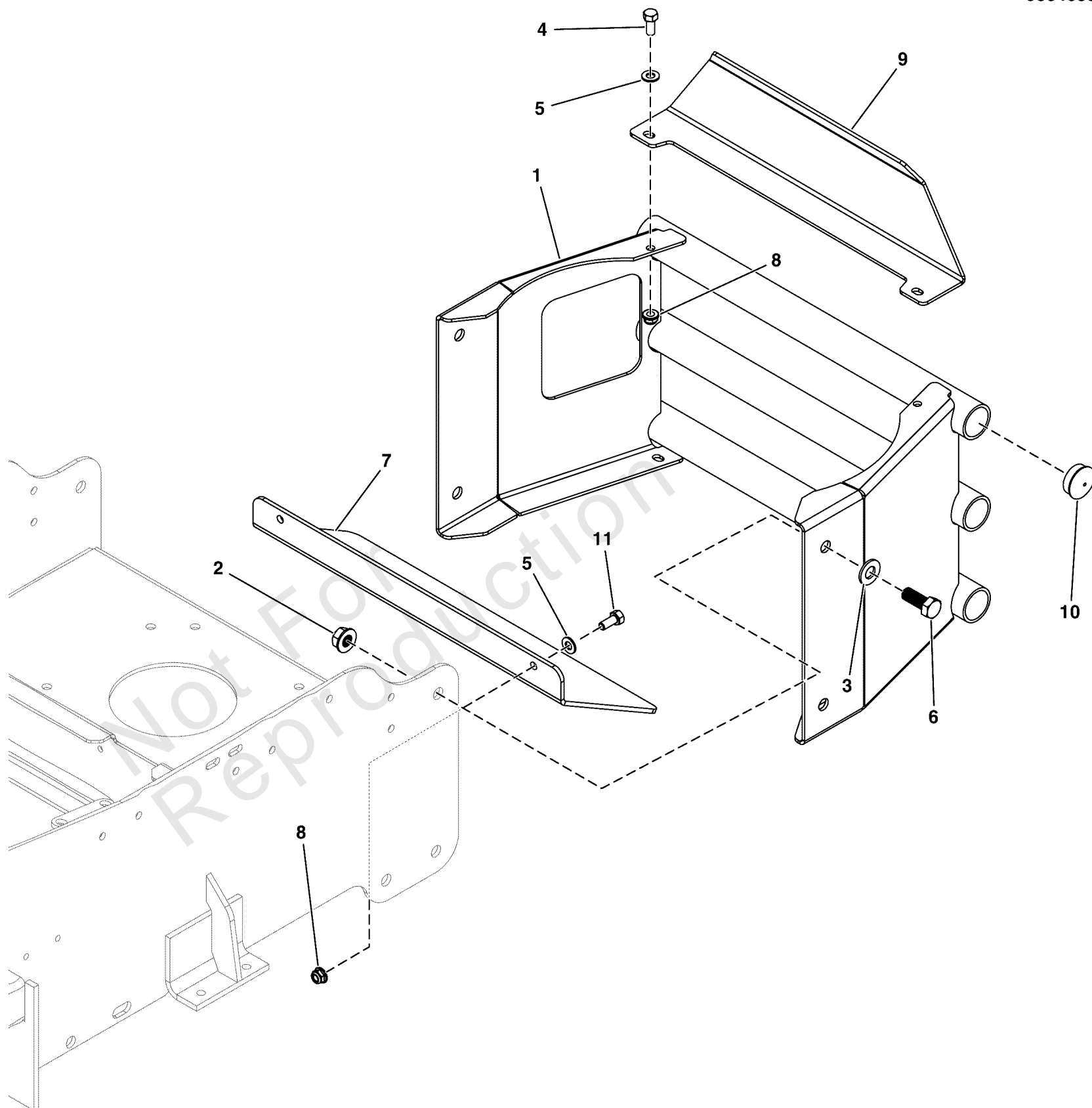

## Rear Bumper Group

REF NO	PART NO	QTY	DESCRIPTION
1	5415153B	1	WELD, BUMPER, F60Z - RED
2	5025396	4	NUT, Hex Flange, Nylock, 1/2-13
3	5025158	4	WASHER, 1/2 SAE
4	5025011X6	2	BOLT, 5/16-18 X 3/4 GD5
5	5025155	4	WASHER, 5/16" SAE
6	5025017X8	4	BOLT, 1/2-13 X 1, GD5 YZ
7	5403593A	1	SHIELD, MUFFLER - BLK
8	5025392	4	NUT, 5/16-18 HEX NYLOCK FLANGE NUT
9	5415154B	1	PLATE, CARB GUARD, F60Z - RED
10	5023484	6	PLUG, PANEL, 1.25 - BLACK
11	5025011X8	2	BOLT, 5/16-18 X 1" GRD5 YZ

Not For Reproduction

# Seat Mount and Floor Group S/N: 4000369918 and Below

Note: Unless noted otherwise, use the standard torque specifications

Mfg. No: 5901895

5304636  
5304839

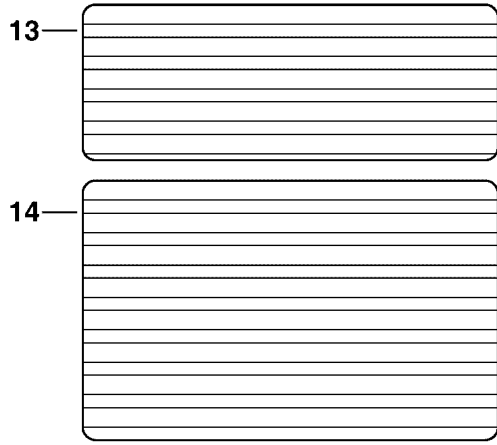

## Seat (P/N 5105039) Service Parts:

28 - 4" Track Assembly w/ Hardware

29 - Back Assembly

30 - Cushion Assembly

31 - Arm Pad Assembly

32 - Arm Pad

33 - Seat Switch

34 - Seat Switch (w/ twist-in assembly)

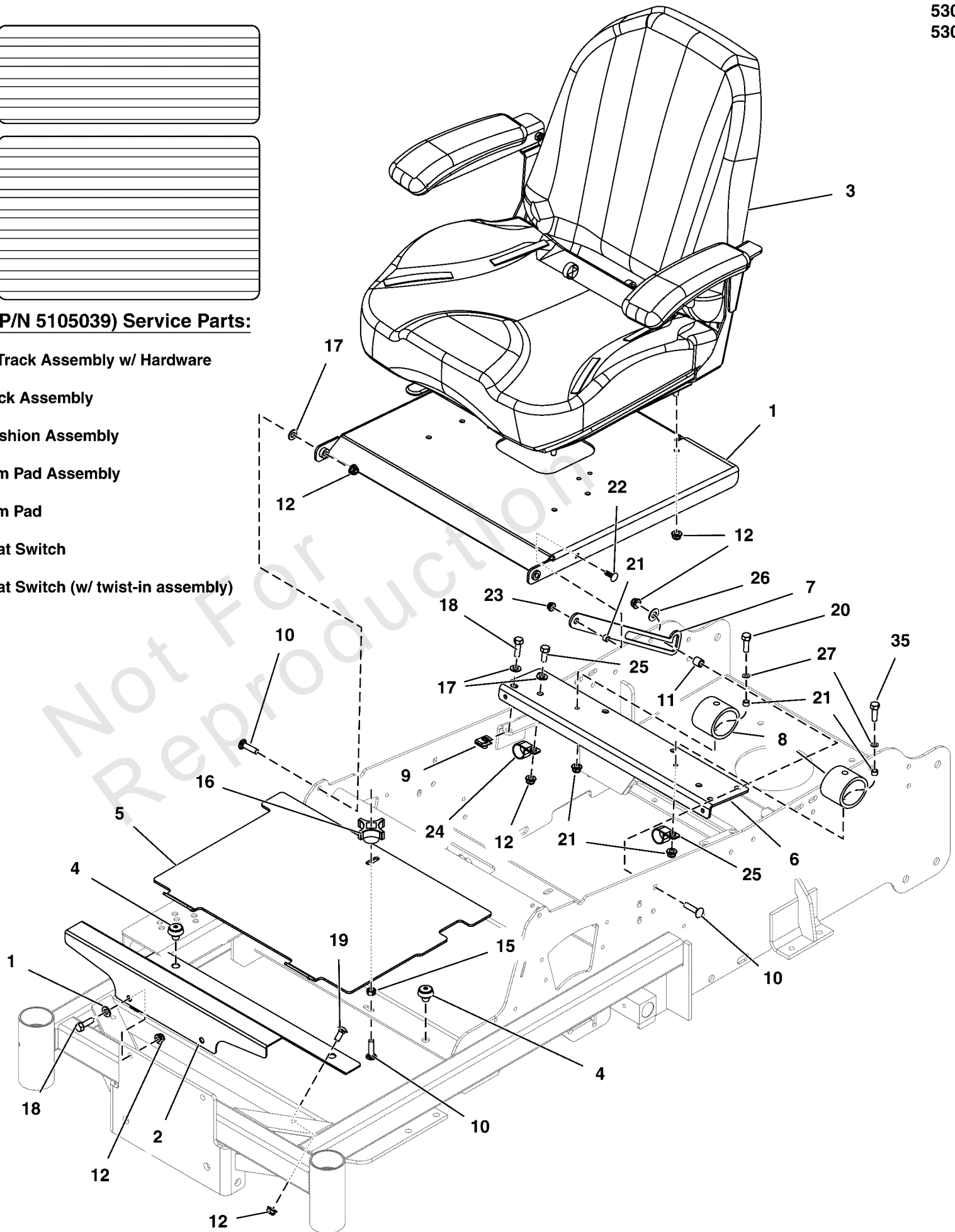

## Seat Mount and Floor Group S/N: 4000369918 and Below

REF NO	PART NO	QTY	DESCRIPTION
1	5415237B	1	WELD, PLATE, SEAT MOUNT - RED
2	5410382B	1	PLATE, FLOOR RIGID, 50XT - RED
3	5105039	1	SEAT, 907 WITH ARM RESTS W/ SWITCH
4	197546	4	MNT, VBRTN, RBBR
5	5410381B	1	PLATE, REMOVABLE FLOOR, 50XT - RED
6	5415416B	1	MOUNT, SEAT STOP - RED
7	5415678A	1	PLATE, SEAT STOP LATCH - BLK
8	5105128	2	BUMPER, GBR-6, 200 IN-LBS
9	5022308	4	BODY CLIP, 5/16-18-7GA MATERIAL
10	5025145X10	4	BOLT, 5/16-18 X 1-1/4, CARRIAGE, GD5, CZ
11	5102148	1	SPACER, .33 X .50 X .50, YZ
12	5025392	13	NUT, 5/16-18 HEX NYLOCK FLANGE NUT
13	5101374	1	SAFETY WALK, FLOOR REST, 16.00 X 6.00
14	5101333	1	SAFETY WALK, FLOOR PLATE, S50X, 10X17.13
15	80003675	1	NUT, 5/16-1/8, HEX, CNTR LK, ZINC PHOS/OIL
16	1670578	1	KNOB-INT THR .312-18 4-ARM 2.12WD 1.06LG
17	5025155	10	WASHER, 5/16" SAE
18	5025011X8	8	BOLT, 5/16-18 X 1" GRD5 YZ
19	5025145X6	2	BOLT, 5/16-18 X 3/4, CARRIAGE, GD5, CZ
20	5025010X8	1	BOLT, 1/4-20 X 1" GD5 CZ
21	5021878	3	SPACER, .25 X .37 X .25
22	80003518	1	BOLT, 1/4-20X0.750, GR5, STD NECK, SQ, ZC/CL
23	5025391	3	NUT, 1/4-20 Hex Nylock Flange
24	5025558	2	CLAMP, TUBE & WIRING, 1.062 ID
25	5101932	1	CLAMP, VINYL INSULATED, .625
26	5025337	1	WASHER, 5/16" USS
27	5025154	1	WASHER, 1/4 SAE
28	5104741X1	1	4" SL TRACK SET - 9" FLAT - W/HDWR -(SV)
29	5104741X3	1	BACK ASSEMBLY FOR 907 -(SV)
30	5104741X4	1	CUSHION ASSEMBLY FOR 907 -(SV)
31	5104681X3	1	LEFT AND RIGHT HAND ARM ASSEMBLIES, C13 SEAT -(SV)
32	5104681X4	1	ARM PAD, C13 SEAT -(SV)
33	7023354	1	SWITCH, SEAT -(SV)
34	5100541	1	SWITCH, NC, W/ TWIST-IN BASE -(SV)
35	5025010X10	1	BOLT, 1/4-20 X 1-1/4 GD5 CZ

# Seat Mount and Floor Group S/N: 4000369919 to 4000875836

Note: Unless noted otherwise, use the standard torque specifications

Mfg. No: 5901895

5304636  
5304839

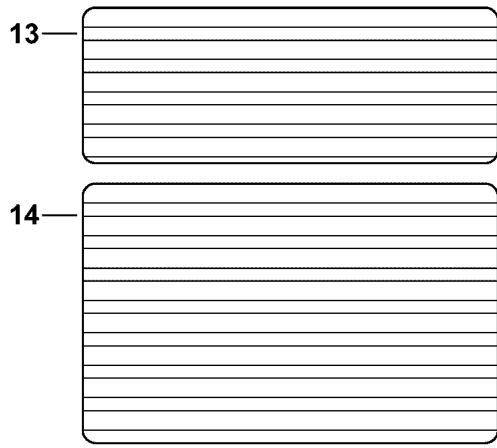

## Seat (P/N 5106754) Service Parts:

- 28 - 4" Track Assembly w/ Hardware
- 29 - Back Assembly
- 30 - Cushion Assembly
- 31 - Arm Pad Assembly
- 32 - Arm Pad
- 33 - Seat Switch
- 34 - Seat Switch (w/ twist-in assembly)

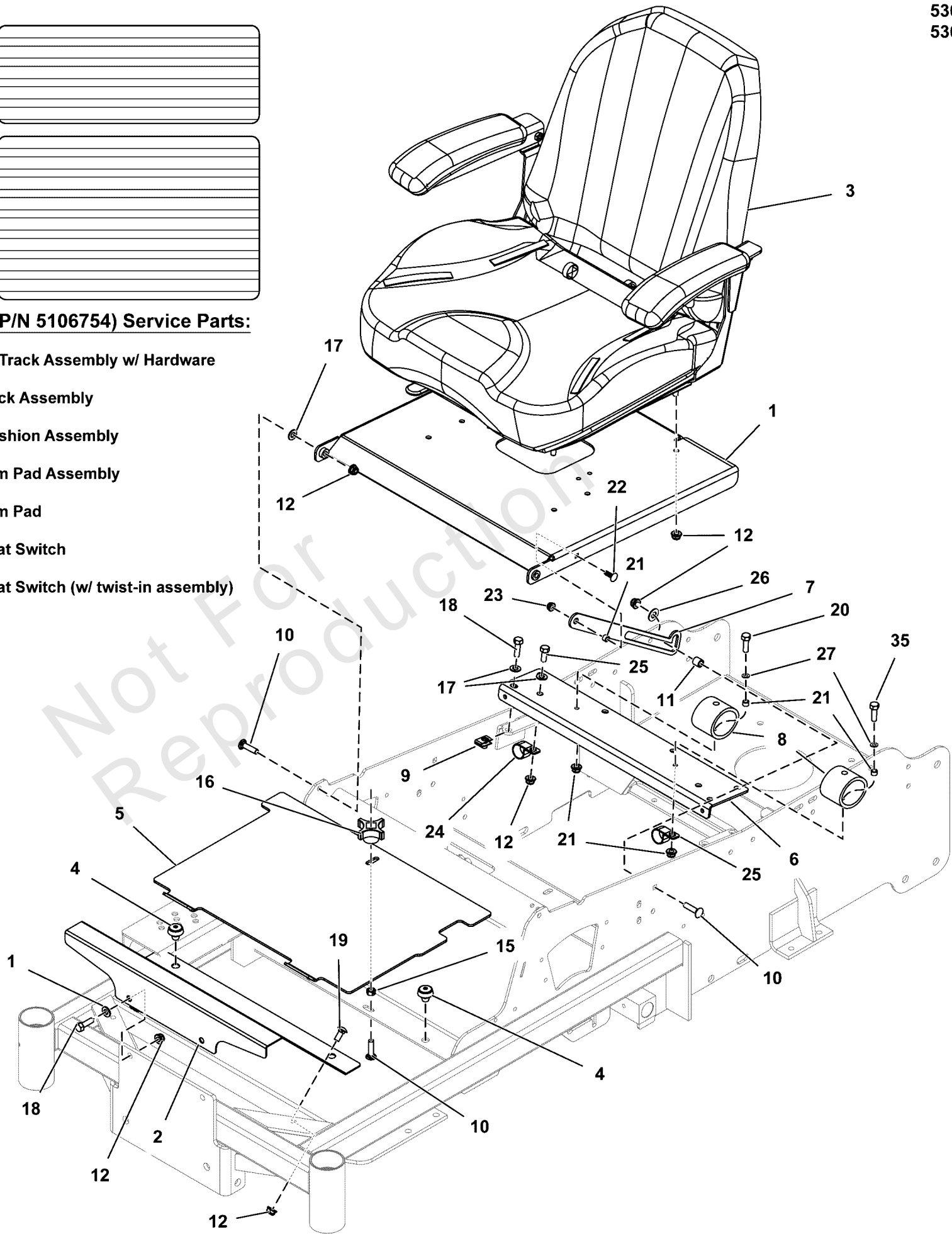



**Seat Mount and Floor Group S/N: 4000369919 to 4000875836**

REF NO	PART NO	QTY	DESCRIPTION
1	5415237B	1	WELD, PLATE, SEAT MOUNT - RED
2	5410382B	1	PLATE, FLOOR RIGID, 50XT - RED
3	5106754	1	SEAT, 907, W/ARM REST, W/SWITCH, NO BEAD
4	197546	4	MNT, VBRTN, RBBR
5	5410381B	1	PLATE, REMOVABLE FLOOR, 50XT - RED
6	5415416B	1	MOUNT, SEAT STOP - RED
7	5415678A	1	PLATE, SEAT STOP LATCH - BLK
8	5105128	2	BUMPER, GBR-6, 200 IN-LBS
9	5022308	4	BODY CLIP, 5/16-18-7GA MATERIAL
10	5025145X10	4	BOLT, 5/16-18 X 1-1/4, CARRIAGE, GD5, CZ
11	5102148	1	SPACER, .33 X .50 X .50, YZ
12	5025392	13	NUT, 5/16-18 HEX NYLOCK FLANGE NUT
13	5101374	1	SAFETY WALK, FLOOR REST, 16.00 X 6.00
14	5101333	1	SAFETY WALK, FLOOR PLATE, S50X, 10X17.13
15	80003675	1	NUT, 5/16-1/8, HEX, CNTR LK, ZINC PHOS/OIL
16	1670578	1	KNOB-INT THR .312-18 4-ARM 2.12WD 1.06LG
17	5025155	10	WASHER, 5/16" SAE
18	5025011X8	8	BOLT, 5/16-18 X 1" GRD5 YZ
19	5025145X6	2	BOLT, 5/16-18 X 3/4, CARRIAGE, GD5, CZ
20	5025010X8	1	BOLT, 1/4-20 X 1" GD5 CZ
21	5021878	3	SPACER, .25 X .37 X .25
22	80003518	1	BOLT, 1/4-20X0.750, GR5, STD NECK, SQ, ZC/CL
23	5025391	3	NUT, 1/4-20 Hex Nylock Flange
24	5025558	2	CLAMP, TUBE & WIRING, 1.062 ID
25	5101932	1	CLAMP, VINYL INSULATED, .625
26	5025337	1	WASHER, 5/16" USS
27	5025154	1	WASHER, 1/4 SAE
28	5104741X1	1	4" SL TRACK SET - 9" FLAT - W/HDWR -(SV)
29	5106754X1	1	SEAT BACK ASSEMBLY, 186693VN1328 -(SV)
30	5106754X2	1	SEAT CUSHION ASSEMBLY, 186694VN1328 -(SV)
31	5105039X1	1	KIT, ARMREST (185872VN1328) -(SV)
32	5104681X4	1	ARM PAD, C13 SEAT -(SV)
33	7023354	1	SWITCH, SEAT -(SV)
34	5100541	1	SWITCH, NC, W/ TWIST-IN BASE -(SV)
35	5025010X10	1	BOLT, 1/4-20 X 1-1/4 GD5 CZ

# Seat Mount and Floor Group S/N: 4000875837 and Above

Note: Unless noted otherwise, use the standard torque specifications

Mfg. No: 5901895

5304636  
5304839

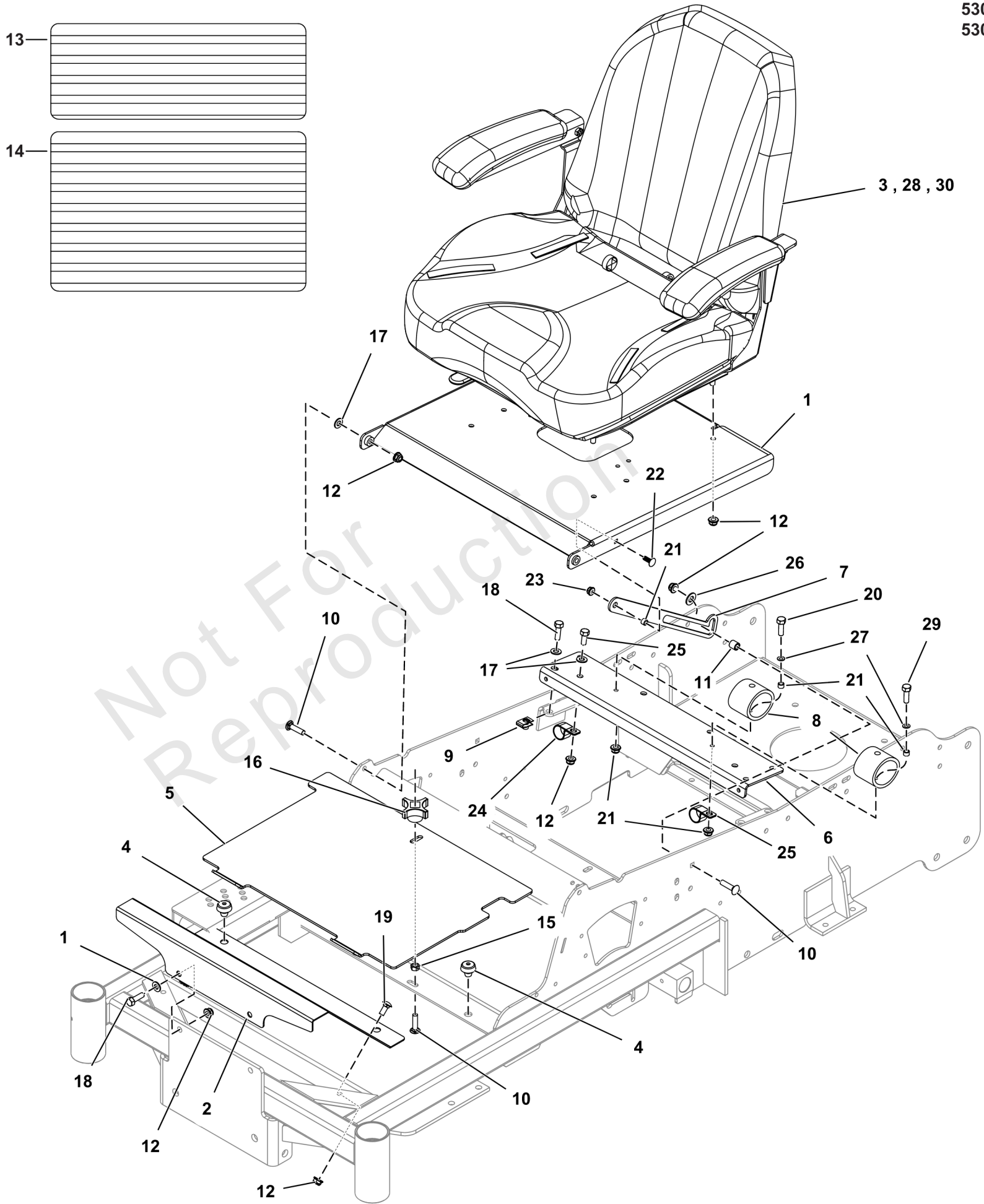

## Seat Mount and Floor Group S/N: 4000875837 and Above

REF NO	PART NO	QTY	DESCRIPTION
1	5415237BFS	1	SEAT PLATE ASSEMBLY
2	5410382BFS	1	PLATE, FLOOR
3	84003662	1	SEAT -(S/N: 4002295457 and below)
3-1	5104741X1	1	4" SL TRACK SET - 9" FLAT - W/HDWR -(S/N: 4002295457 and below)(Not illustrated.)
3-2	5108190X3	1	BACK ASSEMBLY -(S/N: 4002295457 and below)(Not illustrated.)
3-3	5108190X4	1	CUSHION ASSEMBLY -(S/N: 4002295457 and below)(Not illustrated.)
3-4	5108190X2	1	ARM BRACKET W/PAD & HARDWARE -(S/N: 4002295457 and below)(Not illustrated.)
3-5	5108190X2	1	ARM BRACKET W/PAD & HARDWARE -(S/N: 4002295457 and below)(Not illustrated.)
3-6	7023354YP	1	SWITCH, SEAT -(S/N: 4002295457 and below)(Not illustrated.)
3-7	5100541	1	SWITCH, NC, W/ TWIST-IN BASE -(S/N: 4002295457 and below)(Not illustrated.)
4	197546GS	4	MOUNT-VIBRATION
5	5410381BFS	1	PLATE, FLOOR
6	5415416BFS	1	MOUNT
7	5415678AYP	1	PLATE, SEAT STOP LATCH - RED
8	5105128FS	2	BUMPER
9	5022308SM	4	BODY CLIP, 5/16-18 X
10	5025145X10YP	4	BOLT, 5/16-18 X 1-1/4
11	5102148YP	1	SPACER, .33 X .50X.50
12	703115	13	NUT
13	5101374YP	1	SAFETY WALK, FLOOR RE
14	5101333YP	1	SAFETY WALK, FLOOR PL
15	703164	1	NUT
16	1670578SM	1	KNOB-INT THR .312-18
17	703350	10	WASHER
18	5025011X8FS	8	BOLT
19	5025145X6SM	2	BOLT, 5/16-18 X 3/4",
20	5025010X8SM	1	BOLT, 1/4-20 X 1", GD
21	5021878YP	3	SPACER, .25 X .37
22	703575	1	BOLT, 1/4-20X.750, SQ
23	5025391FS	3	NUT
24	5025558YP	2	CLAMP, TUBE&WIRING
25	5101932YP	1	CLAMP, VINYL COATED,
26	5025337FS	1	WASHER
27	84007033	1	WASHER
28	84006921	1	SEAT -(S/N: 4002295458 to 4002340029)
28-1	84006998	1	COVER, Cushion, Snapper -(S/N: 4002295458 to 4002340029)(Not illustrated)
28-2	84007000	1	COVER, Back, Snapper -(S/N: 4002295458 to 4002340029)(Not illustrated)
28-3	7023354YP	1	SWITCH, SEAT -(S/N: 4002295458 to 4002340029)(Not illustrated)
28-4	5100541YP	1	SWITCH, NC, W/ TWIST-IN BASE -(S/N: 4002295458 to 4002340029)(Not illustrated)
29	5025010X10SM	1	BOLT, 1/4-20 X 1-1/4"
30	84010950	1	SEAT ASSEMBLY w/Arm Rests -(S/N: 4002340029 and Above)

# Seat Mount and Floor Group S/N: 4000875837 and Above

Note: Unless noted otherwise, use the standard torque specifications

Mfg. No: 5901895

5304636  
5304839

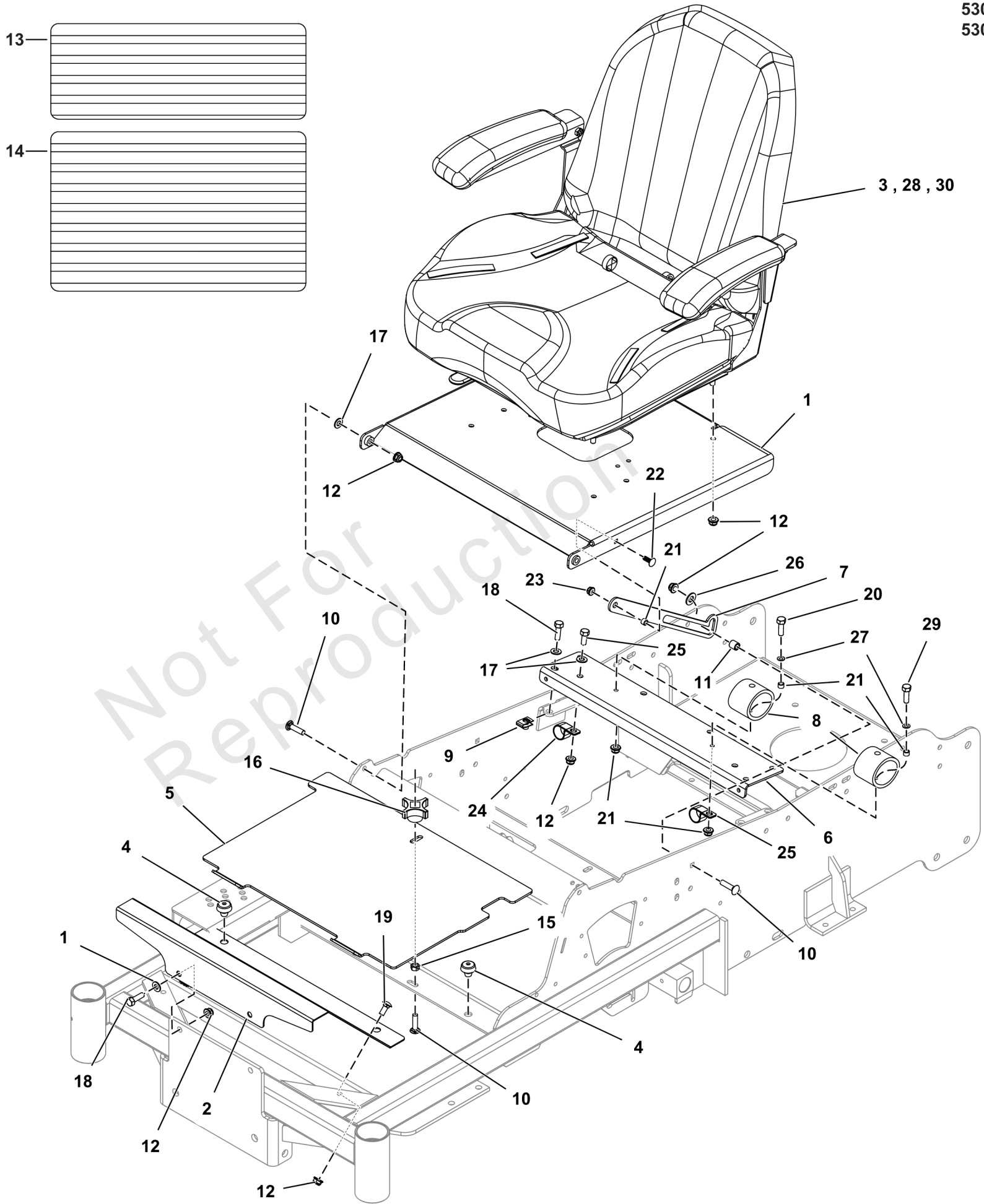

**Seat Mount and Floor Group S/N: 4000875837 and Above**

REF NO	PART NO	QTY	DESCRIPTION
30-1	84011193	1	COVER, Seat Back -(S/N: 4002340029 and Above)(Not illustrated)
30-2	84011194	1	CUSHION, Seat -(S/N: 4002340029 and Above)(Not illustrated)
30-3	7023354YP	1	SWITCH, SEAT -(S/N: 4002340029 and Above)(Not illustrated)
30-4	5100541YP	1	SWITCH, NC, W/ TWIST-IN BASE -(S/N: 4002340029 and Above)(Not illustrated)

Not For Reproduction

# Spindle SERVICE PARTS - 5061095

Note: Unless noted otherwise, use the standard torque specifications

Mfg. No: 5901895

5061095

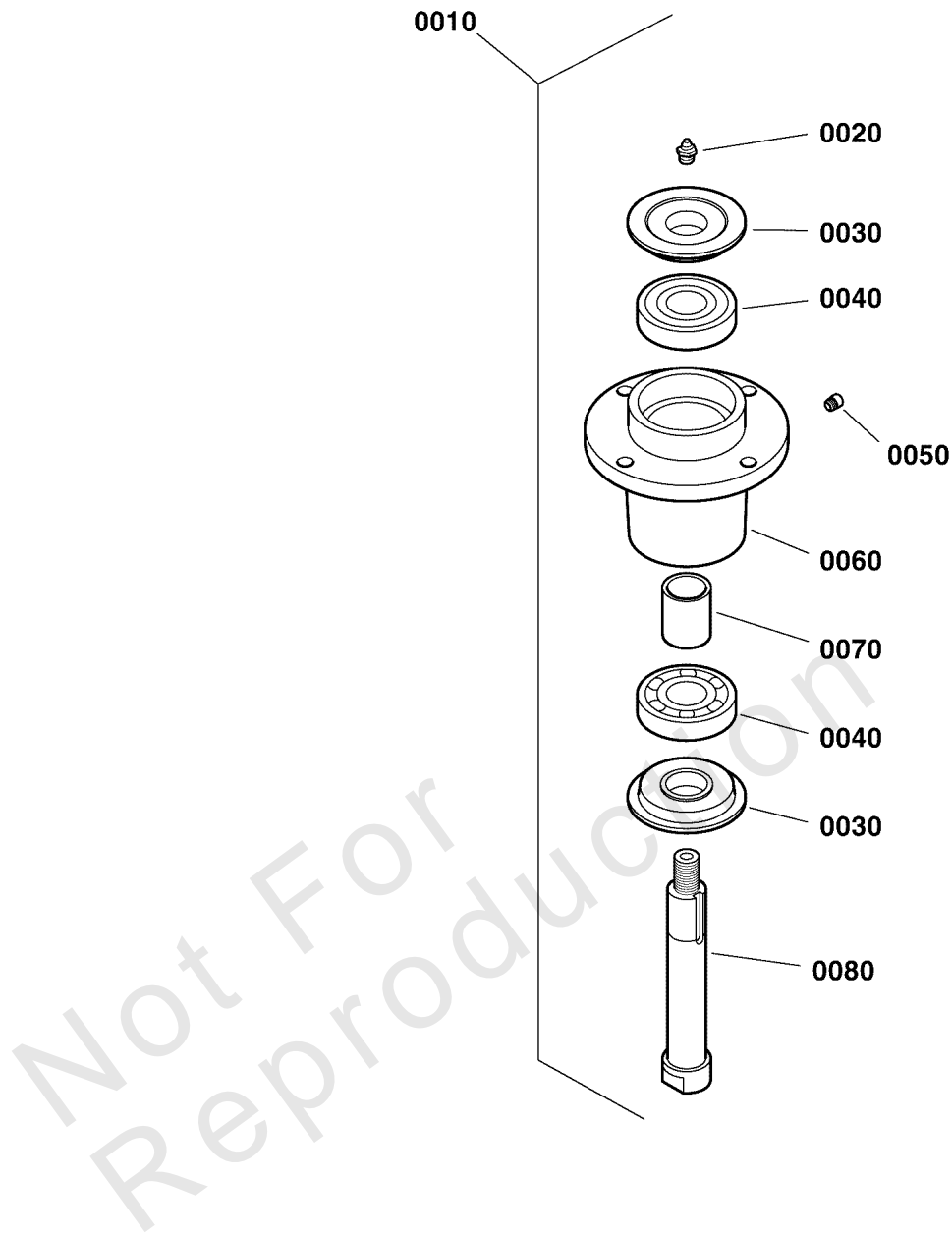

## Spindle SERVICE PARTS - 5061095

REF NO	PART NO	QTY	DESCRIPTION
0010	5061095	1	SPINDLE, ASSM, ALUMINUM - 5.25 -(Nut and Washer Sold Separately) (Includes items #0020 - 0080)
0020	5023329	1	FITTING, 1/8 NPT STR, SHORT
0030	5049793	2	TRASH SHIELD
0040	5023330	2	BEARING, .98 X 2.44 X .67
0050	5023296	1	FITTING, RELIEF, 1-5 PSI
0060	5061097	1	HOUSING, SPINDLE
0070	5061099	1	SPACER, 1.00 X 1.25 X 1.75
0080	5061098	1	SPINDLE SHAFT

Not For Reproduction

# Transaxle Drive Group - Kawasaki Models

Note: Unless noted otherwise, use the standard torque specifications

Mfg. No: 5901895

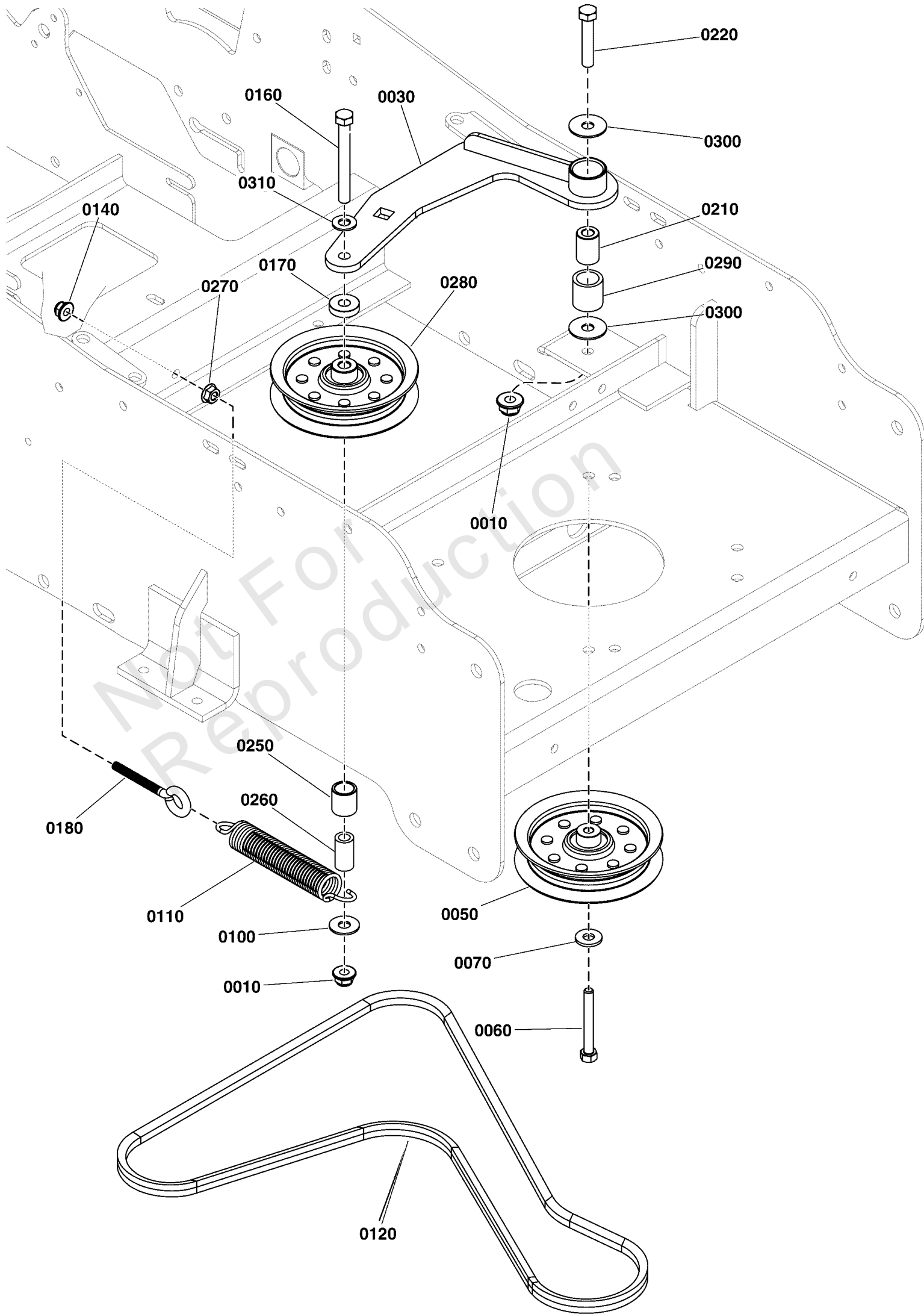



## Transaxle Drive Group - Kawasaki Models

REF NO	PART NO	QTY	DESCRIPTION
0010	5025394	2	NUT, 3/8 - 16 HEX NYLOCK FLANGE
0030	5415852A	1	WELD, IDLER ARM, F60Z/S50XT - BLK
0050	5101380	1	PULLEY-IDLER, 4.06OD, .375ID, .75W STL
0060	5025401	1	WASHER, 3/8" USS
0070	5025544	1	BOLT,HEX FLG,SER GD5 3/8-16X2, PATCH,CZ
0100	5025401	1	WASHER, 3/8" USS
0110	1715435	1	SPRING, EXTENSION, 1.00
0120	5105189	1	BELT, SPA-SEC, 66.26" EL, ARAMID, WRAPED
0140	5025392	1	NUT, 5/16-18 HEX NYLOCK FLANGE NUT
0160	5025013X28	1	BOLT, 3/8-16 X 3-1/2" GD5 CZ
0170	5044960	1	SPACER, .39 X 1.00 X .25, PM, CZ
0180	5025141X26	1	EYE BOLT,5/16-18 X3.5,2.13THRD,.55EYE,CZ
0210	5042658	1	SPACER, .38 X .75 X 1.06, YZ
0220	5025013X16	1	BOLT, 3/8-16 X 2, GD5, CZ
0250	5102946	1	SPACER, .64 X .82 X .88, CZ
0260	1674669	1	SPACER-0.39 IDX0.625ODX1.15 LG CASE HARD
0270	5025127	1	NUT, 5/16-18 HEX SERRATED FLANGE (SMALL)
0280	5101380	1	PULLEY-IDLER, 4.06OD, .375ID, .75W STL
0290	5020876B	1	BUSHING, BRASS, 3/4 X 1 X 1
0300	5025165	2	WASHER, 3/8" Fender
0310	5025156	1	WASHER, 3/8 SAE

# Transmission SERVICE PARTS

Note: Unless noted otherwise, use the standard torque specifications

Mfg. No: 5901895

SERVICE SCHEMATIC FOR:  
**ZL-GMEF-3L7B-1PLX (5101024)**  
**ZL-GMEF-SL7B-1PLX (5109242)**  
**ZL-KMEF-3L7C-1PLX (5101025)**  
**ZL-KMEF-SL7B-1PLX (5109243)**

AVAILABLE PARTS LISTED ARE  
 IDENTICAL FOR BOTH TRANSMISSIONS

**ITEMS NOT SHOWN:**

200 - SEAT KIT  
 \*- PARTS INCLUDED IN 200, - "SEAL KIT"

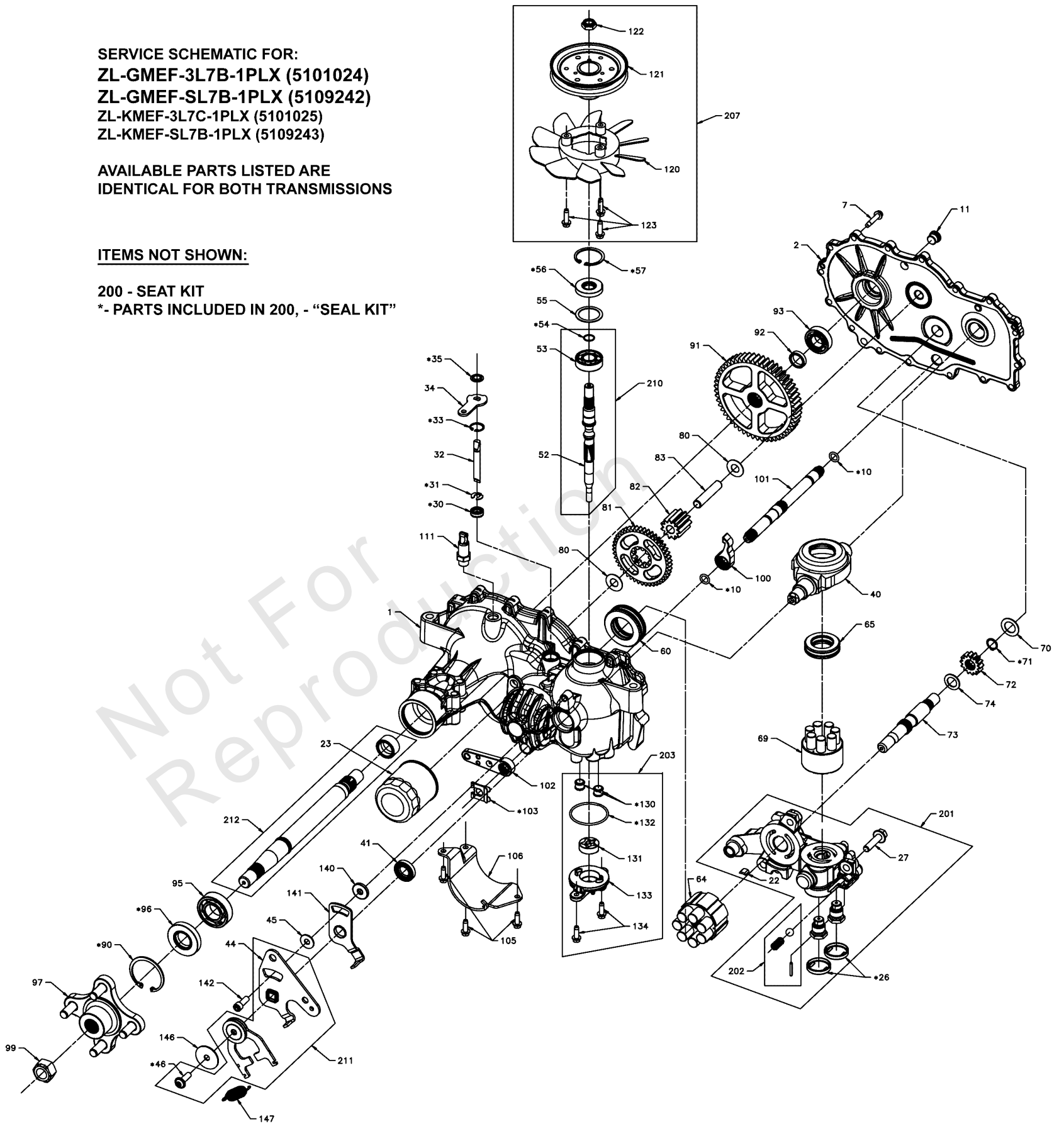

## Transmission SERVICE PARTS

REF NO	PART NO	QTY	DESCRIPTION
23	5101026X1	1	FILTER, OIL, ZT2800
41	5101026X2	1	SEAL, CONTROL ARM, 18X32X7, #51140
56	5101026X3	1	SEAL, LIP, 17 X 40 X 7
57	5101026X4	1	RING, RET 2.06 INT,
95	5101026X5	1	BEARING BALL, 1.0 X 52 X 15 OPEN 6205M
120	5101024X1	1	FAN
121	5101188X2	1	*PULLEY, HYDRO-GEAR 50302 -*Inspect existing pulley. If pulley has splined hub order part number 5102809X1. If pulley does not, order 5101188X2.
200	5101026X8	1	KIT SEAL
203	5101026X12	1	KIT, CHARGE PUMP, ZT2800, ZT3100
210	5101026X9	1	KIT, INPUT SHAFT
1000	5104580X4	1	KIT, PLUG, BRAKE BORE, OUTBOARD

Not For Reproduction

### Front Wheels & Tires

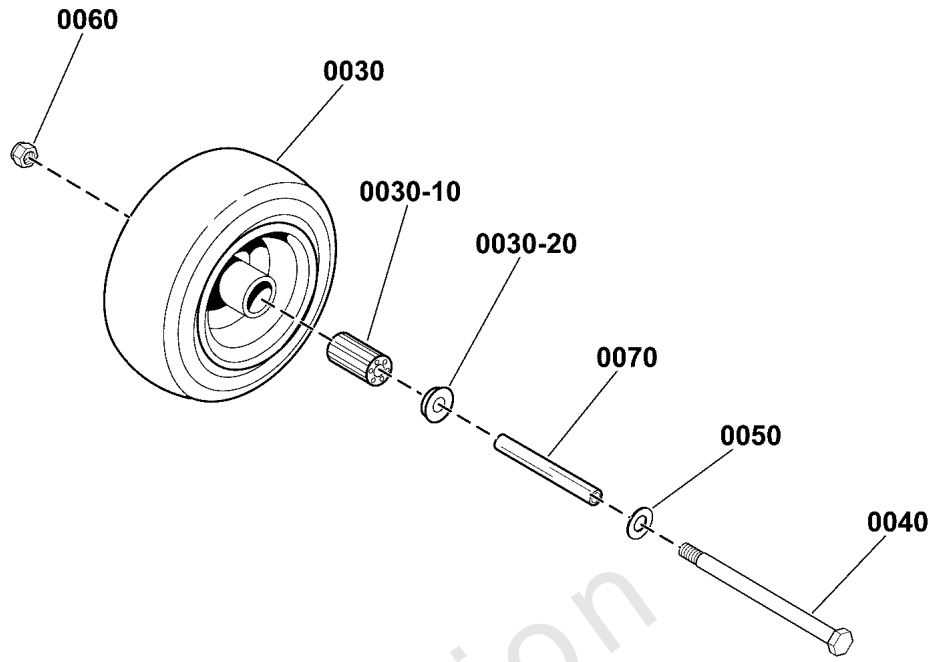

Flat Free Tire

### Rear Wheels & Tires

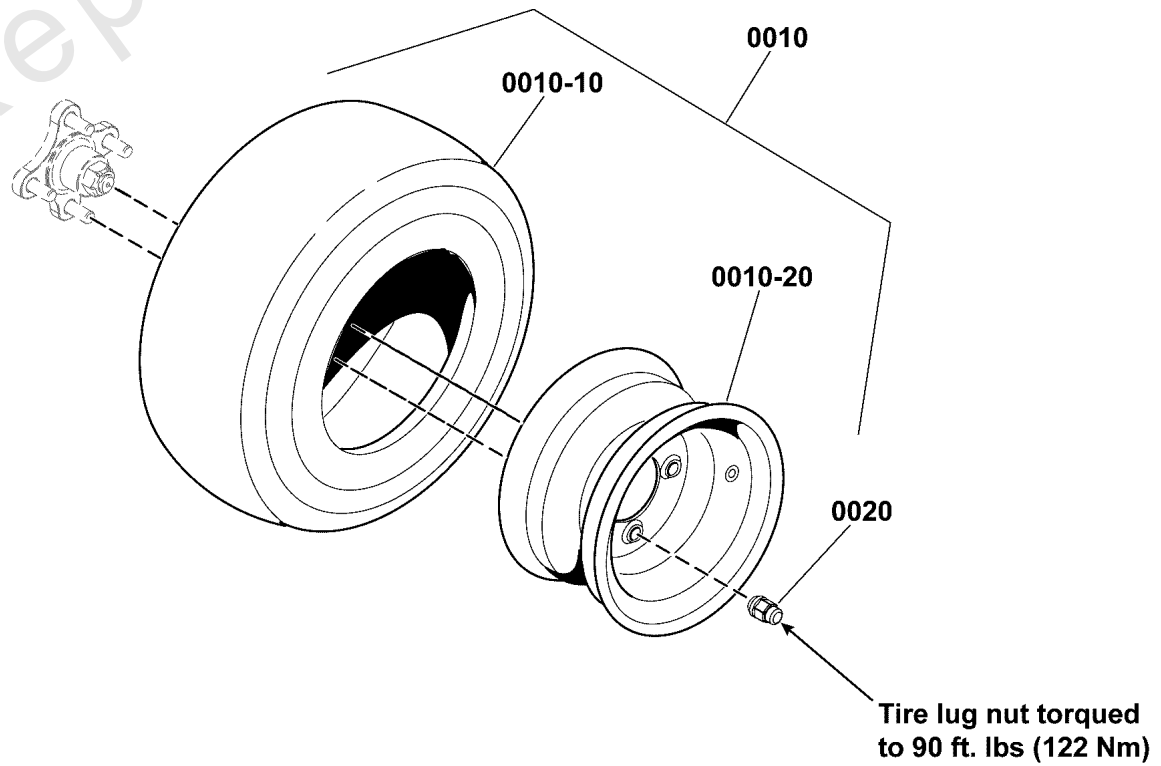

Inflate to 15 psi (1,03 bar)

## Wheel & Tire Group

REF NO	PART NO	QTY	DESCRIPTION
0010	5109045	2	TIRE ASM, 20 X 7 - 10, TURF, 4 BOLT, BLK
0010-10	5101068X1	2	TIRE, 20 X 7 -10 NHS, TURF MASTER -(One per tire)
0010-20	-----	2	WHEEL RIM -(One per tire)
0020	-----	10	LUG NUT, Black -(Originally Black Lug nut - Replacement 5020601SM is silver in color).
0020	5020601SM	10	NUT, 1/2-20, FOR WHEEL BOLT SILVER -(Replacement 5020601SM is silver in color).
0030	5109032	2	TIRE ASM, 11 X 4 -5, FF / CB, BLK
0030-10	5101418X1	2	BEARING, CASTER WHEEL, 11 X 4.0 - 5 BEAD LOCK (SV) -(SV)(One per tire)
0030-20	5021043	4	RETAINER, BEARING (TWO PER TIRE)(SV) -(SV)(Two per tire)
0040	5025017X56	2	BOLT, HEX, 1/2-13 X 7, GD 8, YZ
0050	5025158	2	WASHER, 1/2 SAE
0060	5025396	2	NUT, Hex Flange, Nylock, 1/2-13
0070	5045996	2	AXLE, Front Caster

Not For Reproduction

# Hardware Identification & Torque Specifications

Torque Specification Chart								
FOR STANDARD METRIC MACHINE HARDWARE (Tolerance ± 20%)								
Property Class	5.6		8.8		10.9		12.9	
	Class 5.6		Class 8.8		Class 10.9		Class 12.9	
Size Of Hardware	in/lbs	Nm.	in/lbs	Nm.	in/lbs	Nm.	in/lbs	Nm.
	ft/lbs		ft/lbs		ft/lbs		ft/lbs	
M3	5.88	.56	13.44	1.28	19.2	1.80	22.92	2.15
M4	13.44	1.28	30.72	2.90	43.44	4.10	52.56	4.95
M5	26.4	2.50	60.96	5.75	5.97	8.10	7.15	9.7
M6	44.64	4.3	7.3	9.9	10.3	14	12.1	16.5
M7	5.2	7.1	12.1	16.5	16.9	23	19.9	27
M8	7.7	10.5	17.7	24	25	34	29	40
M10	15	21	35	48	50	67	59	81
M12	26	36	61	83	86.2	117	103	140
M14	42	58	101	132	136	185	162	220
M16	64	88	147	200	210	285	250	340
M18	89	121	202	275	287	390	346	470
M20	126	171	290	390	405	550	486	660
M22	169	230	390	530	559	745	656	890
M24	217	295	497	375	708	960	840	1140
M27	320	435	733	995	1032	1400	1239	1680
M30	435	590	995	1350	1401	1900	1681	2280
M33	590	800	1349	1830	1902	2580	2278	3090
M36	759	1030	1740	2360	2441	3310	2935	3980
M39	988	1340	2249	3050	3163	4290	3798	5150

Torque Specification Chart						
FOR STANDARD MACHINE HARDWARE (Tolerance ± 20%)						
Hardware Grade	No Marks		SAE Grade 5		SAE Grade 8	
	SAE Grade 2		SAE Grade 5		SAE Grade 8	
Size Of Hardware	in/lbs	Nm.	in/lbs	Nm.	in/lbs	Nm.
	ft/lbs		ft/lbs		ft/lbs	
8-32	19	2.1	30	3.4	41	4.6
8-36	20	2.3	31	3.5	43	4.9
10-24	27	3.1	43	4.9	60	6.8
10-32	31	3.5	49	5.5	68	7.7
1/4-20	66	7.6	8	10.9	12	16.3
1/4-28	76	8.6	10	13.6	14	19.0
5/16-18	11	15.0	17	23.1	25	34.0
5/16-24	12	16.3	19	25.8	29	34.0
3/8-16	20	27.2	30	40.8	45	61.2
3/8-24	23	31.3	35	47.6	50	68.0
7/16-14	30	40.8	50	68.0	70	95.2
7/16-20	35	47.6	55	74.8	80	108.8
1/2-13	50	68.0	75	102.0	110	149.6
1/2-20	55	74.8	90	122.4	120	163.2
9/16-12	65	88.4	110	149.6	150	204.0
9/16-18	75	102.0	120	163.2	170	231.2
5/8-11	90	122.4	150	204.0	220	299.2
5/8-18	100	136	180	244.8	240	326.4
3/4-10	160	217.6	260	353.6	386	525.0
3/4-16	180	244.8	300	408.0	420	571.2
7/8-9	140	190.4	400	544.0	600	816.0
7/8-14	155	210.8	440	598.4	660	897.6
1-8	220	299.2	580	788.8	900	1,244.0
1-12	240	326.4	640	870.4	1,000	1,360.0

The guides and ruler furnished below are designed to help you select the appropriate hardware.



Nut, M8

Thread Diameter (mm)

Inside Diameter (in)      Threads per inch

Nut, 1/2-16



Screw, M8- 1.25 x 25

Thread Diameter (mm)      Distance between threads (mm)      Body Length (mm)

Body Diameter      Threads per inch      Body Length (in)

Screw, 1/2- 16 x 2



## Standard Hardware Sizing

When a washer or nut is identified as 1/2" (M8), this is the *Nominal size*, meaning the *inside diameter* is 1/2 inch (8mm metric thread diameter); if a second number is present it represents the *threads per inch* (distance between threads).

When bolt or capscrew is identified as 1/2 - 16 x 2" (M8 - 1.25 x 50), this means the *Nominal size*, or body diameter is 1/2 inch (8mm metric thread diameter), the second number, 16, represents the *threads per inch*, (*distance between threads*). The final number is the body length of the bolt or screw, 2 inches (50mm).

## NOTES

- These torque values are to be used for all hardware excluding: locknuts, self-tapping screws, thread forming screws, sheet metal screws and socket head setscrews.
- Recommended seating torque values for locknuts:
  - for prevailing torque locknuts - use 65% of grade 5 torques.
  - for flange whizlock nuts and screws - use 135% of grade 5 torques.
- Unless otherwise noted on assembly drawings, all torque values must meet this specification.

## Common Hardware Types

Hex Head Capscrew



Washer



Carriage Bolt



Hex Nut

## Wrench & Fastener Size Guide

1/4" Bolt or Nut Wrench—7/16"	5/16" Bolt or Nut Wrench—1/2"	3/8" Bolt or Nut Wrench—9/16"	7/16" Bolt or Nut Wrench (Bolt)—5/8" Wrench (Nut)—11/16"	1/2" Bolt or Nut Wrench—3/4"
M6 Bolt or Nut Wrench—10mm	M8 Bolt or Nut Wrench—13mm	M10 Bolt or Nut Wrench—17mm	M12 Bolt or Nut Wrench—19mm	M14 Bolt or Nut Wrench—22mm

