



Parts Manual

Mfg. No: 5902144
300S Series w/ 42" Mower Deck (300S,
42, B23, NA)



1692125 - Cart, Dump (10 Cu. Ft.)
1696692-00 - Cargo Bed Kit.
1696687YP - Extended Engine Protect.
1687855YP - Rhino Grip.
1687856YP - Rhino Grip, Ratcheting.
1697373A-00 - Bagging Boot, Blade & Baffle, 42".
1697408A-00 - Kit, ZT Catcher, Twin, CS.
5601518 - Mulch Kit for 300s ZTR w/ 42" Deck.
5601517 - LED Headlight Kit.

Not For
Reproduction

Model Components	Page
42" Mower Deck - Clutch & Support Group.....	4
42" Mower Deck Group - Housing, Arbors, and Blades.....	6
Body & Fuel Tank Group.....	8
Controls Group.....	10
Decal Group.....	12
Electrical Group.....	14
Electrical Schematic - Charging Circuit.....	16
Electrical Schematic - Cranking Circuit.....	18
Electrical Schematic - Ignition Grounding Circuit/Op. Pres.....	20
Electrical Schematic - PTO Clutch Circuit.....	22
Engine Group.....	24
EVAP Group.....	26
Frame Group.....	28
Lift Group.....	30
Parking Brake Group (2991641).....	32
Seat Group.....	34
Transaxle Service Parts - 84008002 & 84007995.....	36
Transmission Group.....	40
Wheel & Tire Group.....	42
Torque Specification Chart.....	44

Not For
Reproduction

42" Mower Deck - Clutch & Support Group

Note: Unless noted otherwise, use the standard torque specifications

Mfg. No: 5902144

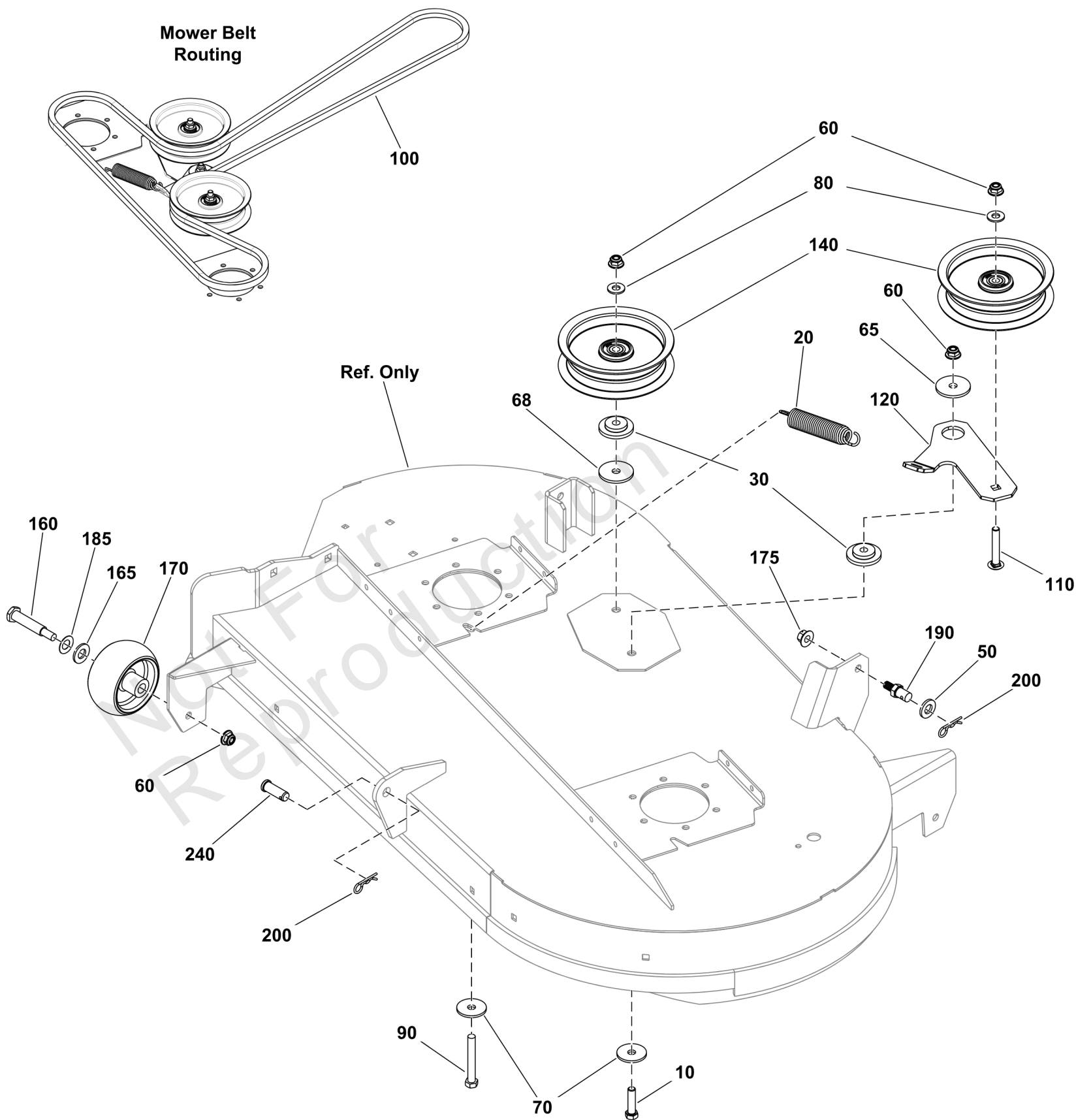

42" Mower Deck - Clutch & Support Group

REF NO	PART NO	QTY	DESCRIPTION
10	703406	1	CAPSCREW,3/8-16X1.5
20	1715772SM	1	SPRING, Extension
30	706128	2	SPACER, IDLER
50	703853	2	WASHER, 0.516IDX1OD
60	5025394SM	5	NUT, 3/8-16 HEX NYLOCK
65	5025305SM	1	WASHER, .41 X 1.75 X
68	5025305SM	1	WASHER, .41 X 1.75 X
70	703591	2	WASHER, .406X1.5X.12
80	703878	2	WASHER, FLAT
90	5025013X22SM	1	BOLT, 3/8-16 X 2-3/4"
100	1758101YP	1	BELT, 113.0 Effective Length
110	7900009SM	1	RHSSNB, 3/8-16 X 2-1/
120	1758789AYP	1	ARM, Idler
140	84003633	2	PULLEY, Flat Idler
160	2108765SM	2	BOLT-WHEEL 3/8-16X2.7
165	5025158SM	2	WASHER, 1/2" SAE
170	1714760SM	2	GAUGE WHEEL
175	1960339SM	2	NUT, Hex Flange, MAC Lock Large, 3/8-16
185	0020X3MA	2	WASHER,SPRING .52X.99
190	704054	2	PIN, 3/8-16
200	7091503SM	3	HAIR PIN, 3/32X1-1/2
240	5025479YP	1	CLEVIS PIN, 1/2 X 1.3

42" Mower Deck Group - Housing, Arbors, and Blades

Note: Unless noted otherwise, use the standard torque specifications

Mfg. No: 5902144

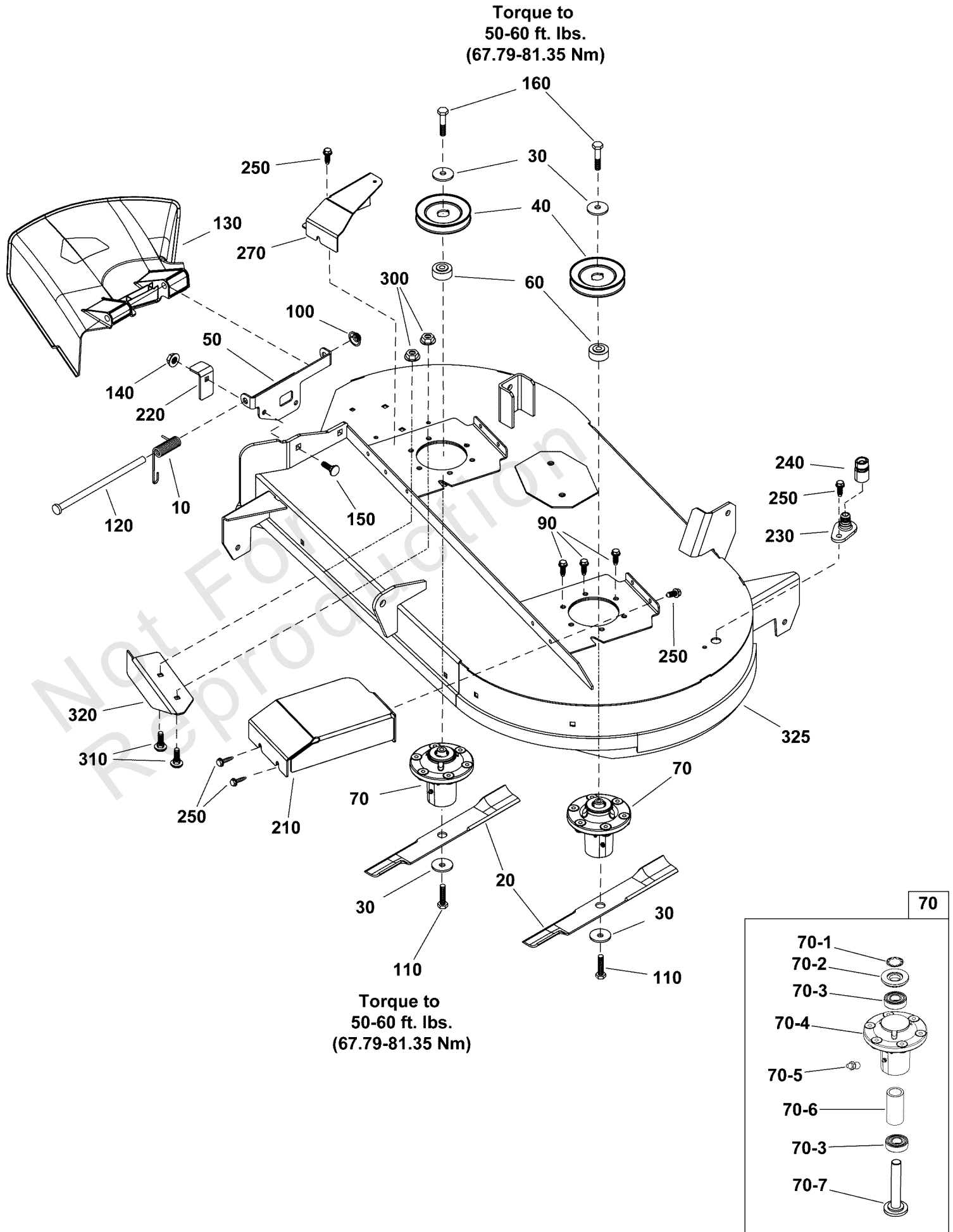

42" Mower Deck Group - Housing, Arbors, and Blades

REF NO	PART NO	QTY	DESCRIPTION
10	7035813SM	1	SPRING, TORSION, SIDE
20	1758878S	1	BLADE SET, 42" DECK (Set of 2 Blades)
30	1656916SM	4	WASHER, SPRING 0.475I
40	1737835YP	2	PULLEY, 4.50
50	1758982AYP	1	BRACKET, DEFLECTOR
60	1737457YP	2	SPACER, Pulley
70	84003173	2	ARBOR ASSEMBLY
70-1	1960766YP	3	RING, SELF LOCKING -(One per spindle)
70-2	84003166	3	COVER, ARBOR -(One per spindle)
70-3	1735399YP	6	BEARING, Ball, 20mm -(One per spindle)
70-4	84003653	3	HOUSING ASSEMBLY -(One per spindle)
70-5	1704314SM	3	LUBE FITTING, .250 DR -(One per spindle)
70-6	84003167	3	SPACER, BEARING -(One per spindle)
70-7	84003170	3	SHAFT, SPINDLE -(One per spindle)
90	704146	12	SCREW, HEX, 5/16-18X1
100	703179	1	PUSHNUT, CAP TYPE
110	2820676SM	2	CAPSCREW-HEX HD 7/16-
120	7104640YP	1	ROD, Deflector
130	7104733YP	1	CHUTE, SIDE DISCHARGE
140	5025128SM	2	NUT, 3/8-16 HEX SERRA
150	703815	2	BOLT, RD SQ 3/8-16X1
160	1921212FS	2	CAPSCREW
210	1758992BMYP	1	COVER, Pulley, LH
220	1758593BMYP	1	PROP, DEFLECTOR
230	1687721YP	1	KIT, WASHOUT PORT -(Includes items #230 & 240)
240	-----	1	WASHOUT PORT, Connector -(Order item #230)
250	703228	7	SCREW, 5/16-18 X .75
270	1759616AYP	1	COVER, Pulley, RH
300	5025392FS	2	NUT
310	703185	2	BOLT, Round Head, Short Square Neck
320	84007914	1	BAFFLE
325	5601481	1	DECK SHELL W/ DECALS, 300S-42, USA -(USA Models Only)
325	5601532	1	DECK SHELL W/ DECALS, 300S-42, AUS -(AUS Models Only)

Body & Fuel Tank Group

Note: Unless noted otherwise, use the standard torque specifications

Mfg. No: 5902144

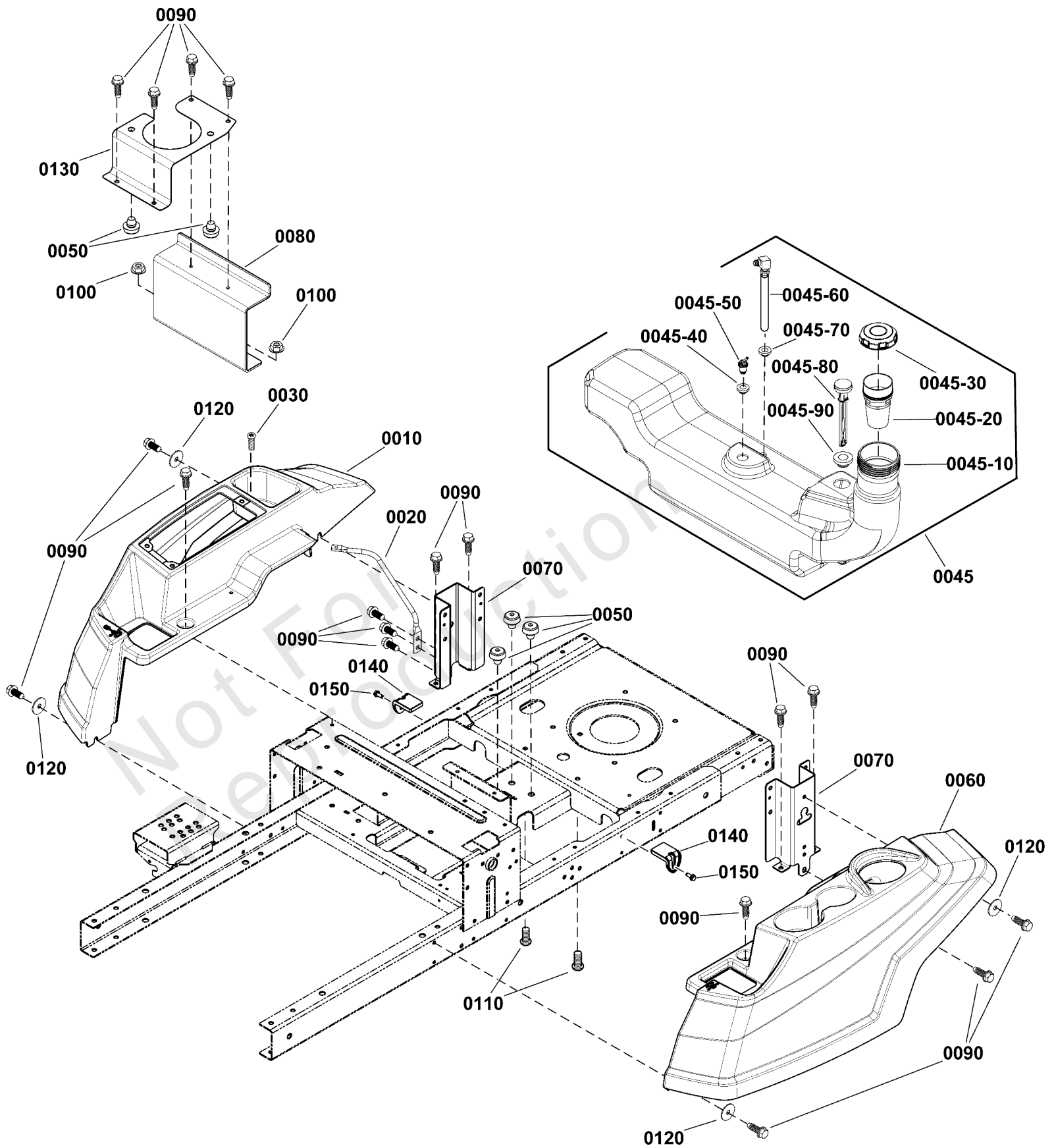

Body & Fuel Tank Group

REF NO	PART NO	QTY	DESCRIPTION
0010	84008779	1	FENDER, Right
0020	1759369YP	1	ROD, Support
0030	7090999FS	1	SCREW
0045	84004694	1	FUEL TANK ASSEMBLY -(Includes item Nos. 0045-10 thru 0045-90)
0045-10	-----	1	TANK, Fuel -(Order item 0045)
0045-20	-----	1	NECK, Fuel Filter -(Order item 0045)
0045-30	1758314YP	1	CAP-FUEL TANK
0045-40	799624	1	GROMMET
0045-50	770046	1	REMOTE VENT ASSEMBLY
0045-60	1758927YP	1	TUBE-PICK UP
0045-70	1726400FS	1	BUSHING
0045-80	1758928YP	1	GAUGE-FUEL
0045-90	84004692	1	GROMMET
0050	197546GS	5	MOUNT-VIBRATION
0060	1758076YP	1	FENDER-LEFT
0070	84007754	2	SUPPORT, Fender
0080	84002196	1	BRACKET
0090	5022308SM	18	BODY CLIP, 5/16-18 X
0100	5025394SM	2	NUT, 3/8-16 HEX NYLOCK
0110	704038	2	SCREW
0120	1960044SM	4	WASHER-0.312(0.33IDX1
0130	1759140AYP	1	STRAP-FUEL TANK
0140	84002197	2	SUPPORT, FUEL TANK
0150	703054	2	SCREW, 1/4-20X0.625

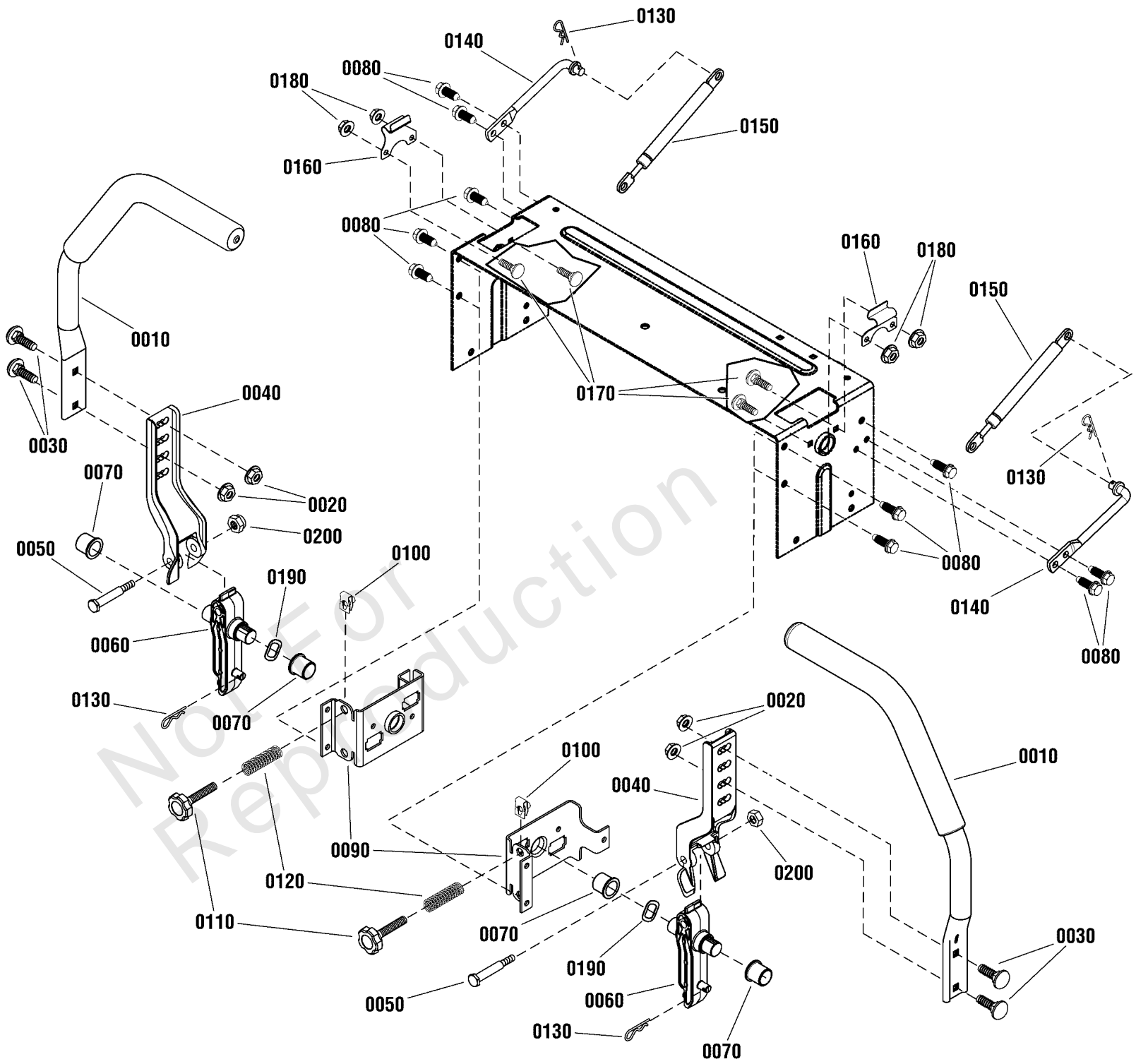

Controls Group

REF NO	PART NO	QTY	DESCRIPTION
0010	1758372YP	2	HANDLE, CONTROL
0020	703115	4	NUT
0030	703483	4	BOLT,5/16-18X1.000,RO
0040	1757965YP	2	ARM, UPPER CONTROL
0050	707624	2	BOLT,SHLDR,5/16-18
0060	1757964YP	2	ARM, LOWER CONTROL
0070	2176440SM	4	BUSHING-0.765IDX
0080	703949	10	SCREW, 5/16-18.625
0090	1758087AYP	2	PIVOT, Inner Control
0100	5022308SM	2	BODY CLIP, 5/16-18 X
0110	1758373YP	2	KNOB, 5/16-18 X 2.5
0120	1650347SM	2	SPRING-COMP 0.50 IDX
0130	5025211SM	4	PIN, HAIR, .0585" X 1
0140	1758463YP	2	ROD, DAMPNER MNT
0150	84001625	2	DAMPENER
0160	1759182YP	2	LATCH, CONTROL ARM
0170	703101	4	BOLT,1/4-20X.75
0180	703463	4	NUT, GR5,1/4-20
0190	707625	2	WSHR, 3 WAVE, .750
0200	703902	2	NUT, HEX, 5/16-18

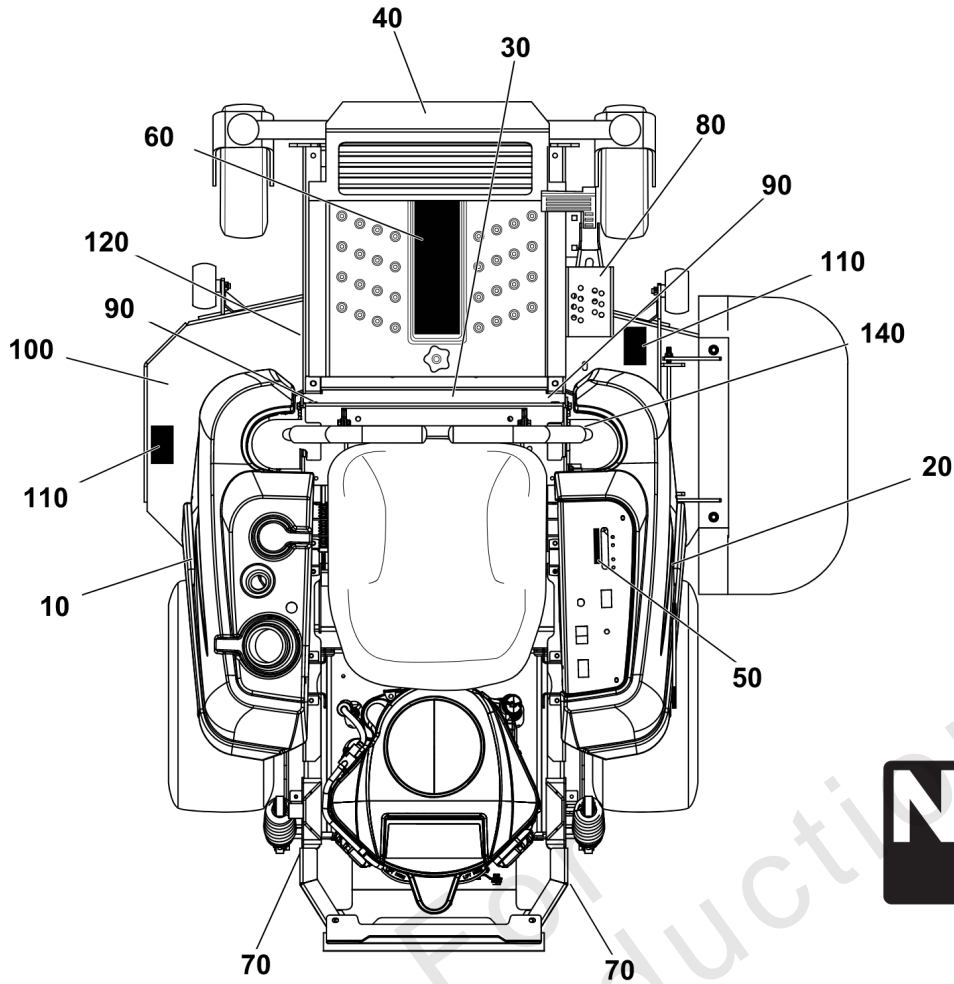

⚠ DANGER

Amputation hazard
Rotating blades cut off arms and legs.

- Stop the mower when children or others are near.
- Do not carry riders (especially children) even with the blades off. They may fall off or return for another ride when you are not expecting it.
- Look down, behind and to the side before changing directions.

Loss of control and roll-over hazard
operating on slopes can be hazardous and cause loss of control and roll-overs.

- Do not operate on slopes over 10 degrees.
- Avoid sudden turns or rapid speed changes.
- Reduce speed and use extreme caution on slopes.
- Avoid turning down slopes; if possible turn up slopes.
- Do NOT operate on slopes when the grass is wet or soil is soft (such as after heavy rains).
- If machine stops forward motion on a slope, stop the blades and drive slowly off the slope.

Water, retaining walls and drop-off hazards
Wheels dropping over edges may result in serious injury, death or drowning.

- Do NOT operate down slope towards or near water, retaining walls or drop-offs.
- Give yourself a minimum of two mower widths of clearance around these hazards.

⚠ WARNING

Fire hazard
Gasoline is flammable. Yard debris is combustible.

- Allow engine to cool for at least 3 minutes before refueling.
- Keep unit cleaned of debris.
- This equipment may create sparks that can start fires around dry vegetation. A spark arrester may be required. Contact local fire agencies for regulations relating to fire prevention requirements.

Avoid serious injury or death
Read the operator's manual before using this product.

- Do NOT operate this machine unless you are trained.
- Know the location and function of all controls.
- Keep safety devices (guards, shields, switches, etc.) in place and working.
- Remove objects that could be thrown by the blade.
- Be sure blade(s) and engine are stopped before placing hands or feet near blade(s).
- When leaving machine, shut off, remove key, and set parking brake.



50



90



140

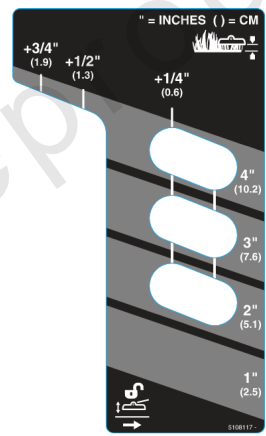

80



40



120



100



110

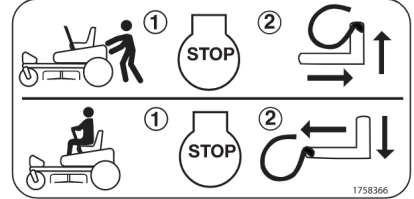

70



30



10

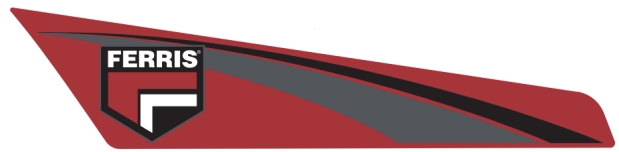

20

Decal Group

REF NO	PART NO	QTY	DESCRIPTION
10	80106105FS	1	DECAL, BRAND
20	80106106FS	1	DECAL, BRAND
30	5104724FS	1	DECAL, BRAND
40	84008369	1	DECAL, Model
50	7105868YP	1	DECAL, ENGINE SPEED
60	84007898	1	DECAL, Main Safety
70	1758366YP	2	DECAL, Tow Release
80	5108117FS	1	DECAL, CUTTING HEIGHT
90	1759724YP	2	DECAL, Tracking Adjustment - ZT
100	84008370	1	DECAL
110	84007896	2	DECAL, Danger, Cut Hand/Foot
120	5104269FS	1	DECAL
140	84011099	1	DECAL, Integrated Parking Brake

Not For Reproduction

Electrical Group

Note: Unless noted otherwise, use the standard torque specifications

Mfg. No: 5902144

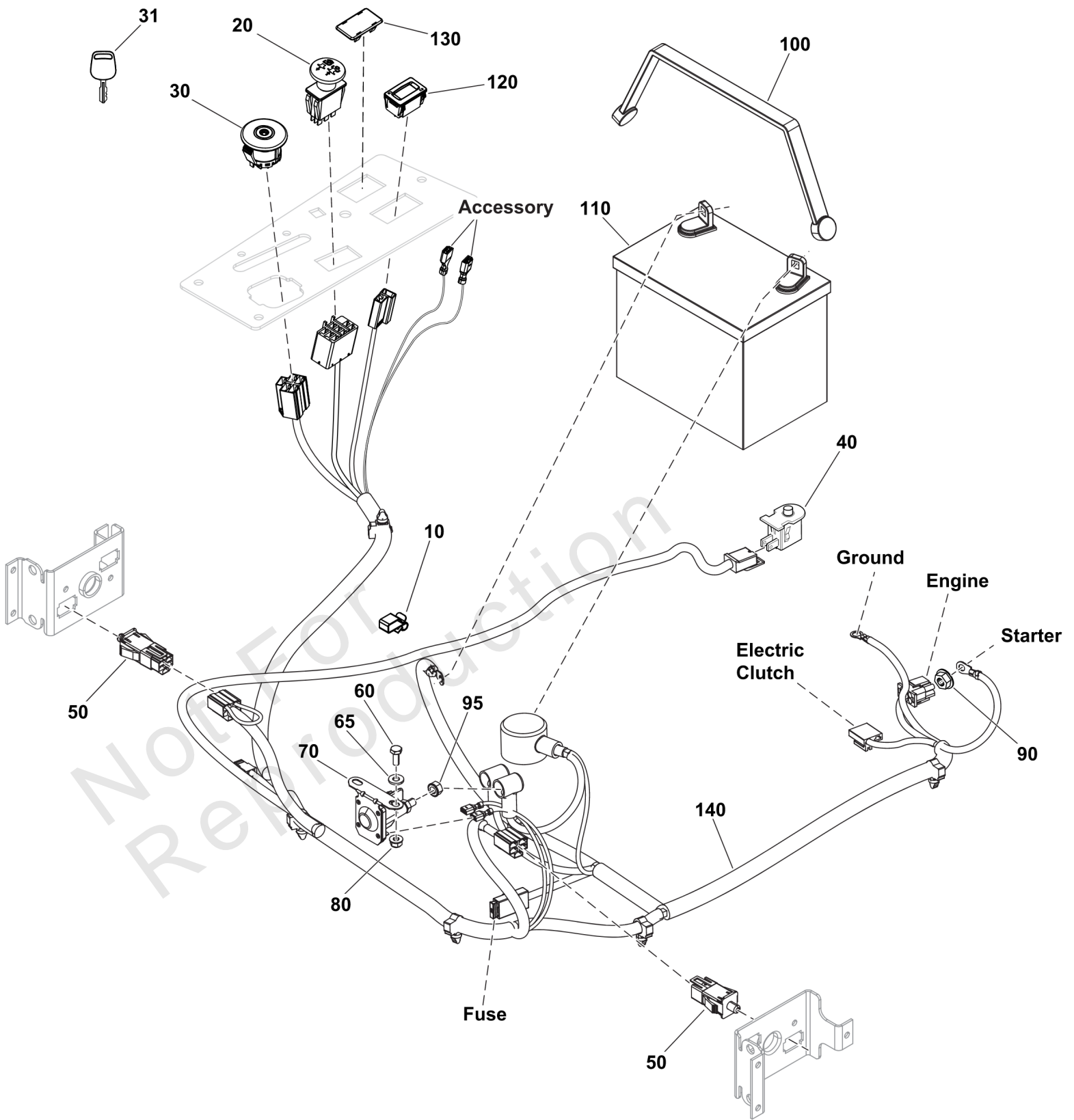

Electrical Group

REF NO	PART NO	QTY	DESCRIPTION
10	2172434SM	1	CLIP- WIRE DIA .390
20	1722887SM	1	SWITCH-PTO PUSH
30	7106169YP	1	SWITCH, IGNITION, DEL
31	7106170FS	1	BLISTER PACK, KEY NO MOW & FOB
40	7023354YP	1	SWITCH, SEAT
50	7022886YP	2	SWITCH, DP NO/NC SNAP
60	703338	2	BOLT,1/4-20X5/8
65	84007033	2	WASHER
70	1755381YP	1	SOLENOID, L-BRACKET
80	5025391FS	2	NUT
90	703061	1	NUT, HEX KEPS, 1/4-20
95	2860750SM	2	NUT-HEX KEPS 5/16-24
100	1722009FS	1	STRAP
110	1722841FS	1	BATTERY
120	1731185SM	1	METER-HOUR DIGITAL NO
130	1722611SM	1	PLUG-HOLE BLACK
140	84007948	1	HARNESS, Wiring

Not For Reproduction

Electrical Schematic - Charging Circuit

Note: Unless noted otherwise, use the standard torque specifications

Mfg. No: 5902144

MAIN WIRE HARNESS - BRIGGS & STRATTON 44U777 ENGINES

80096491A

(If internal schematic of the switch is not shown, the image of the switch represents the back view of the connector as it is connected to the switch.)

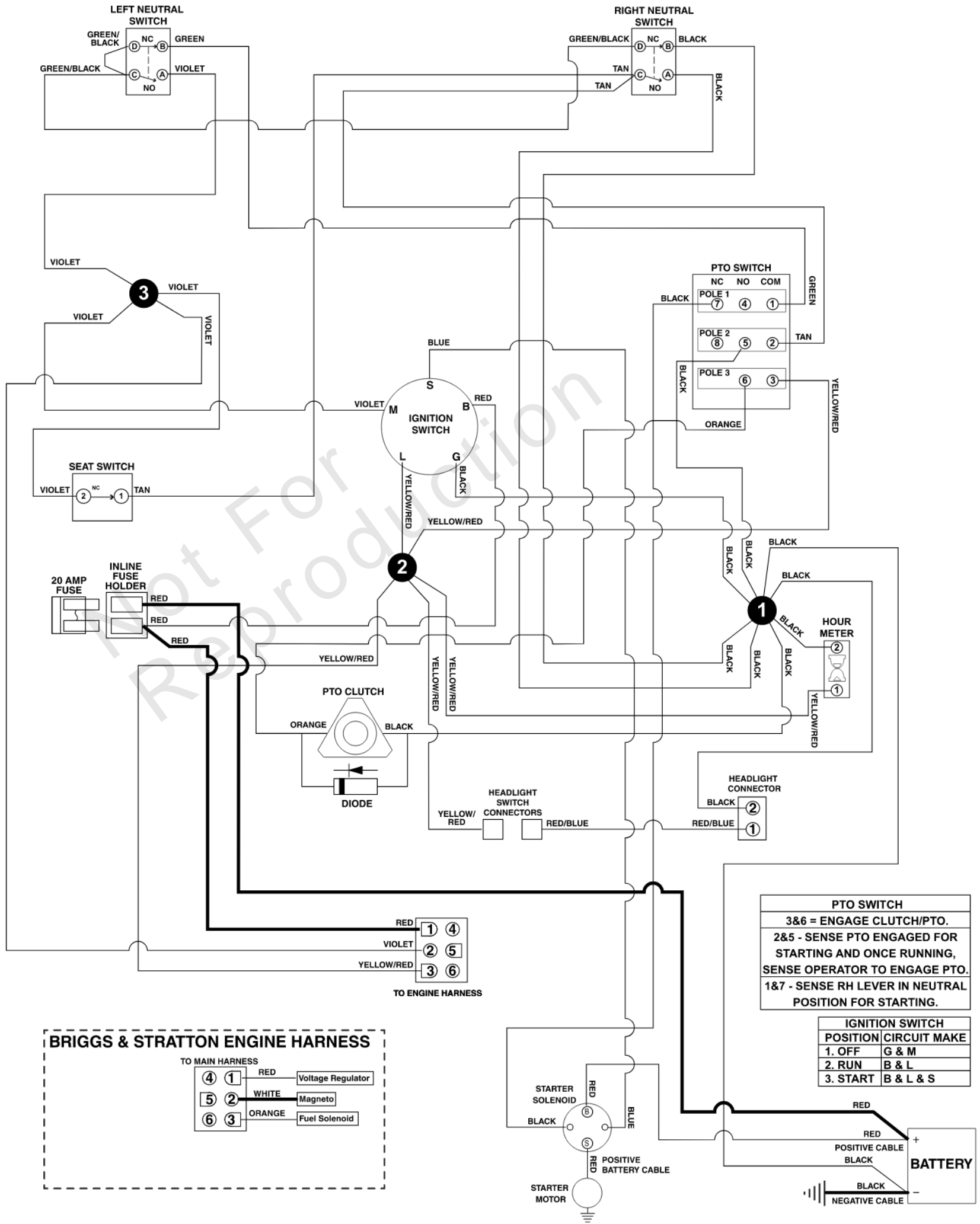

Electrical Schematic - Charging Circuit

REF NO	PART NO	QTY	DESCRIPTION
--------	---------	-----	-------------

Not For Reproduction

Electrical Schematic - Cranking Circuit

Note: Unless noted otherwise, use the standard torque specifications

Mfg. No: 5902144

MAIN WIRE HARNESS - BRIGGS & STRATTON 44U777 ENGINES

80096491A

(If internal schematic of the switch is not shown, the image of the switch represents the back view of the connector as it is connected to the switch.)

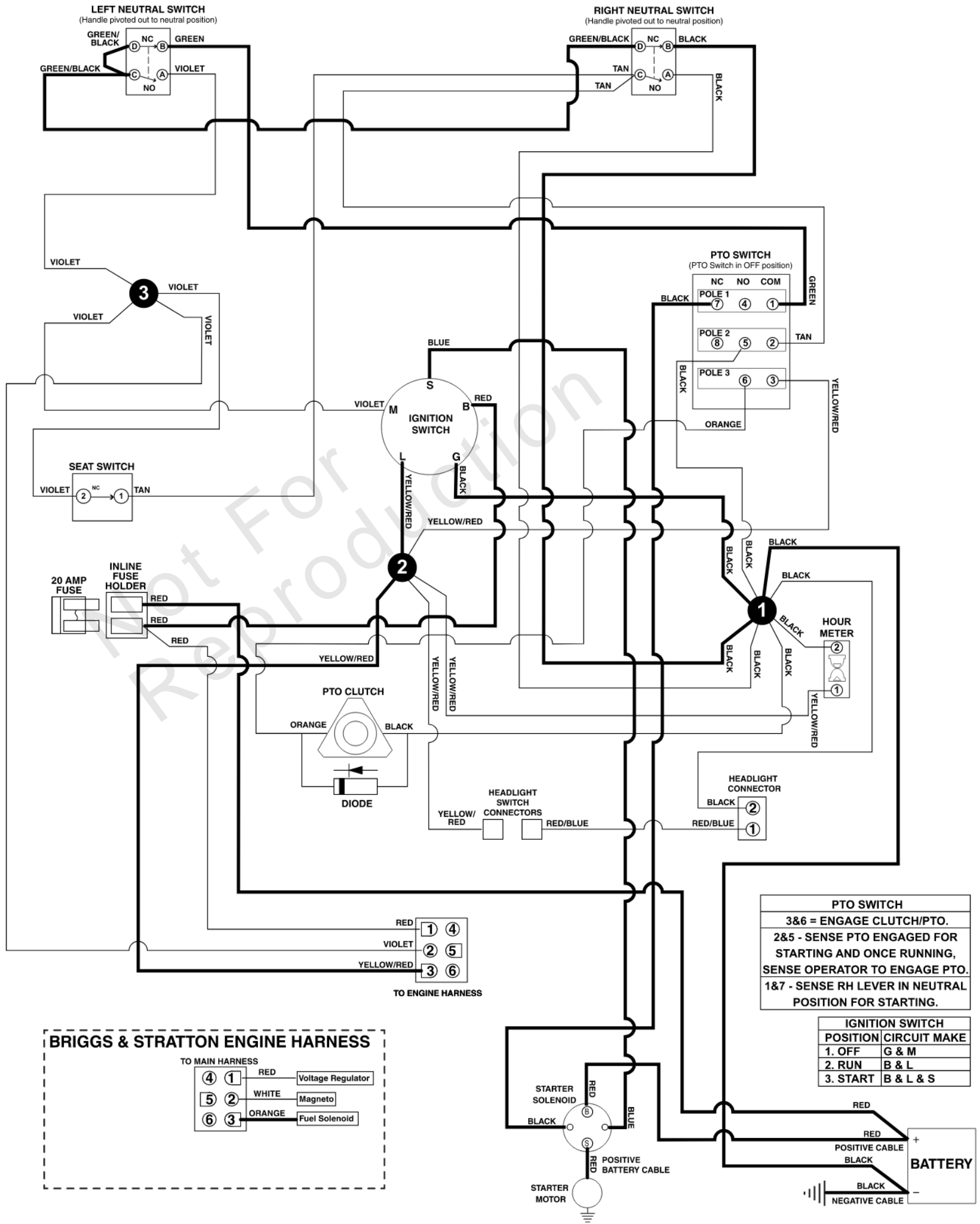

Electrical Schematic - Cranking Circuit

REF NO	PART NO	QTY	DESCRIPTION
--------	---------	-----	-------------

Not For Reproduction

Electrical Schematic - Ignition Grounding Circuit/Op. Pres.

Note: Unless noted otherwise, use the standard torque specifications

Mfg. No: 5902144

MAIN WIRE HARNESS - BRIGGS & STRATTON 44U777 ENGINES

80096491A

(If internal schematic of the switch is not shown, the image of the switch represents the back view of the connector as it is connected to the switch.)

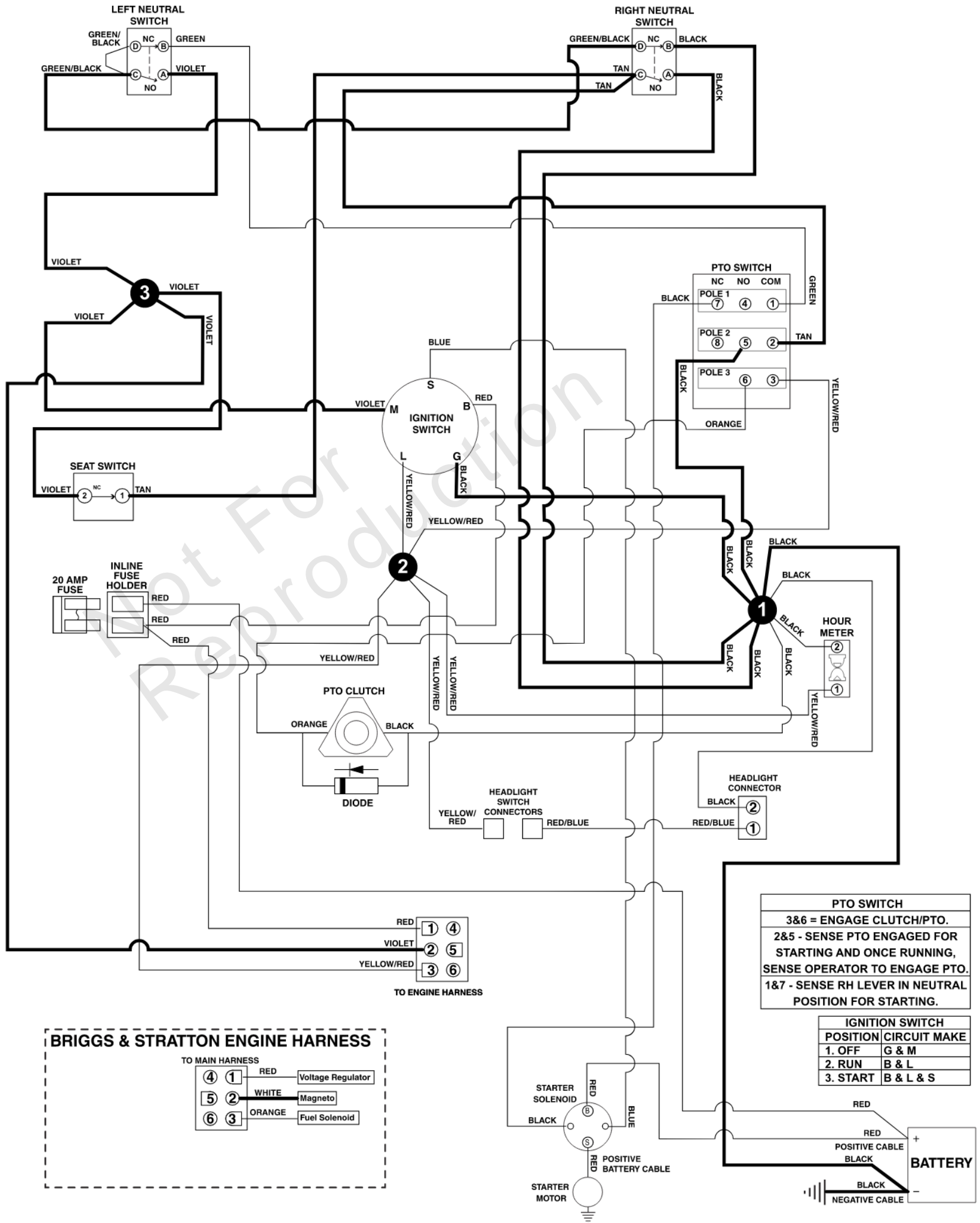

Electrical Schematic - Ignition Grounding Circuit/Op. Pres.

REF NO	PART NO	QTY	DESCRIPTION
--------	---------	-----	-------------

Not For Reproduction

Electrical Schematic - PTO Clutch Circuit

Note: Unless noted otherwise, use the standard torque specifications

Mfg. No: 5902144

MAIN WIRE HARNESS - BRIGGS & STRATTON 44U777 ENGINES

80096491A

(If internal schematic of the switch is not shown, the image of the switch represents the back view of the connector as it is connected to the switch.)

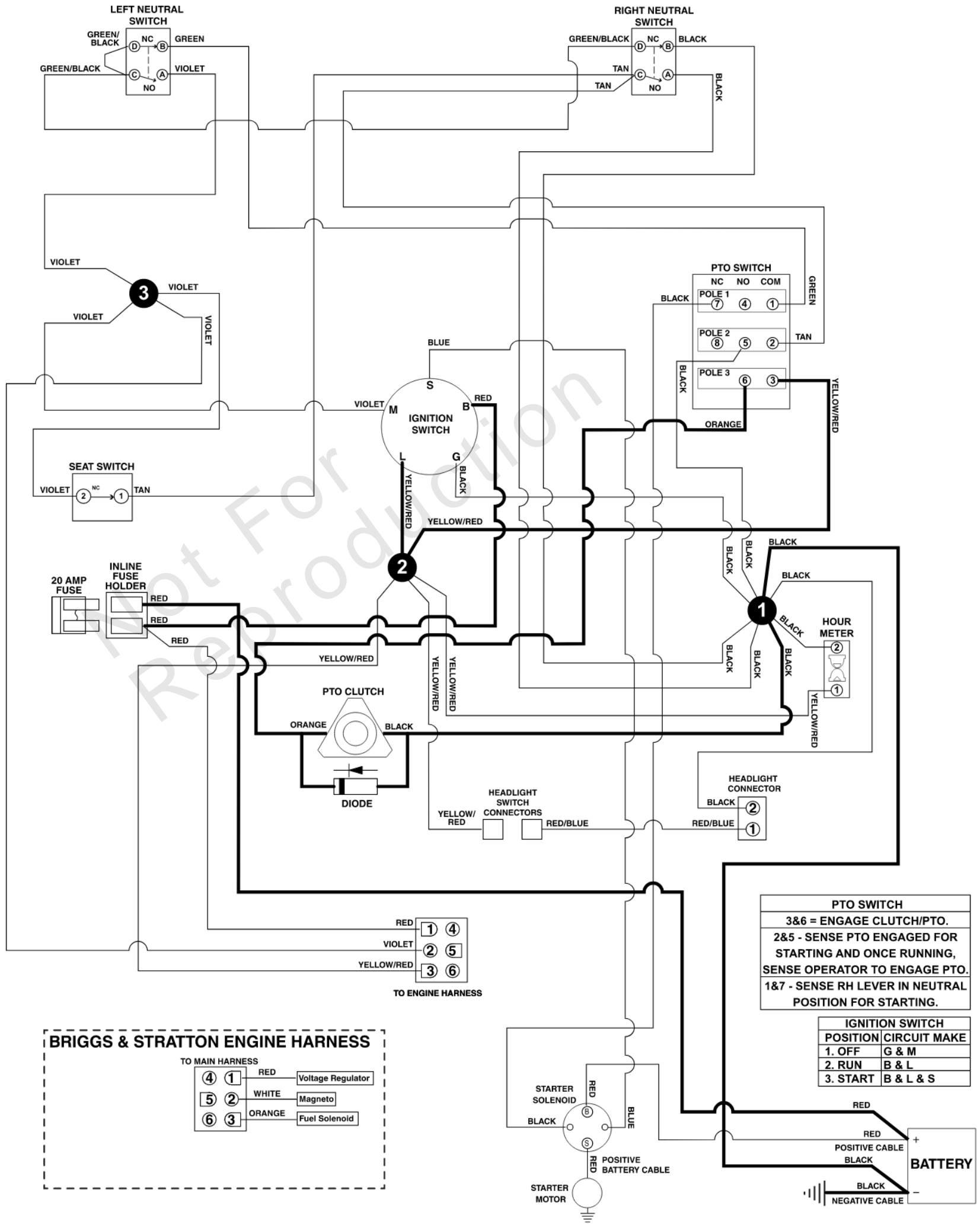

Electrical Schematic - PTO Clutch Circuit

REF NO	PART NO	QTY	DESCRIPTION
--------	---------	-----	-------------

Not For Reproduction

Engine Group

Note: Unless noted otherwise, use the standard torque specifications

Mfg. No: 5902144

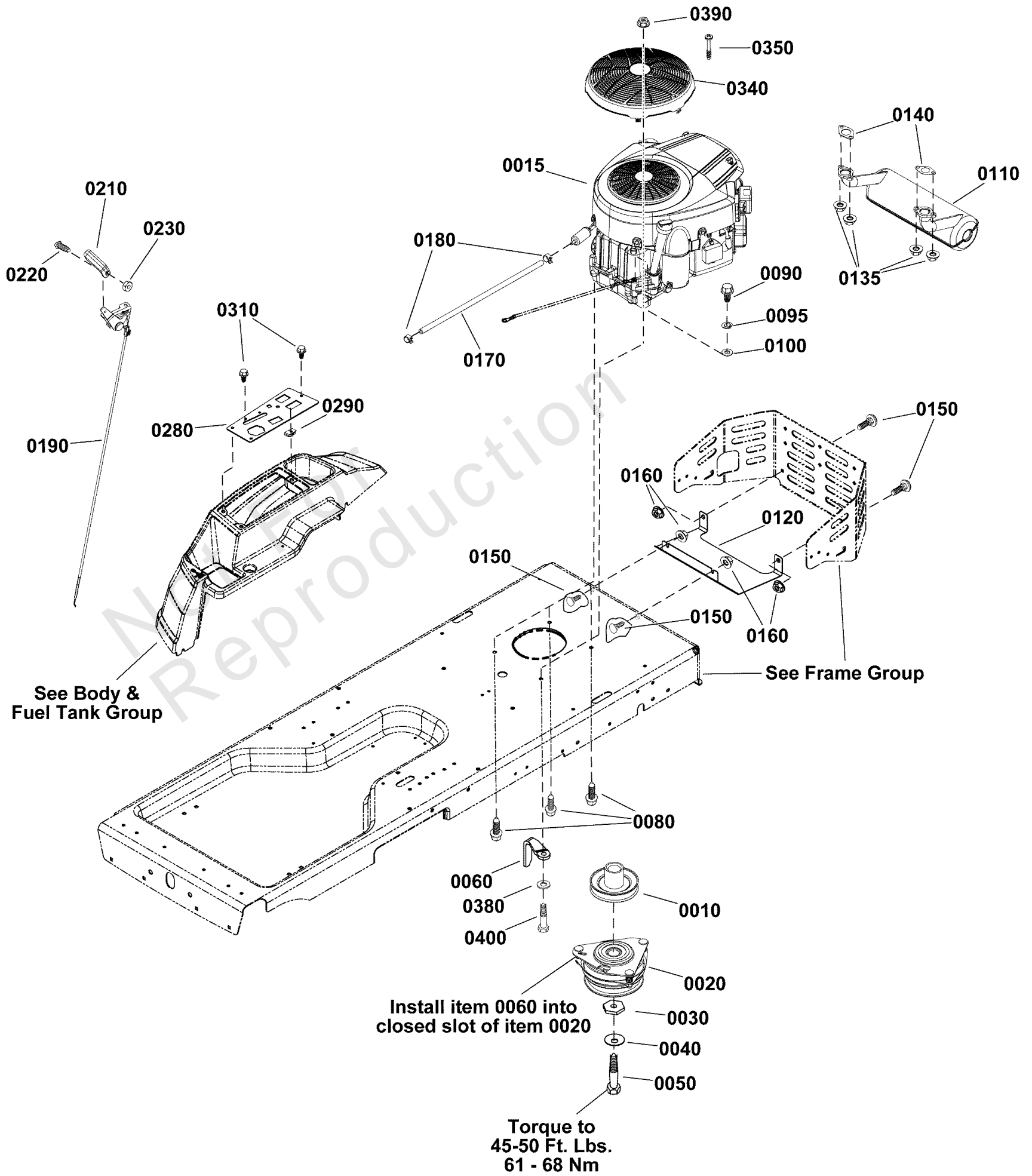

Engine Group

REF NO	PART NO	QTY	DESCRIPTION
0015	44U777-0010-G1	1	* ENGINE, 23 Gross HP B&S, Twin -(Refer to Note: *) (Engine Model: 44U777-0010-G1)
0015	44S977-0046-G1	1	* ENGINE, 25 Gross HP B&S, Twin -(Refer to Note: *) (Engine Model: 44S977-0046-G1)
0010	1757995YP	1	ASSEMBLY-PULLEY
0020	1736105SM	1	CLUTCH, ELECTRIC
0030	1708264SM	1	WASHER, HEX, 0.453ID
0040	1960769YP	2	WASHER, Belleville
0050	771023	1	CAPSCREW, Hex Head, Loctite, 7/16-20 x 3 1/2
0060	1737421AYP	1	GUIDE, Belt
0080	2828635SM	3	SCREW-HEX WSHR HD TAP
0090	703054	1	SCREW, 1/4-20X0.625
0095	703332	1	WASHER
0100	1921880SM	1	LOCKWASHER-EXTERNALTO
0110	1758350YP	1	MUFFLER
0120	1759502AYP	1	SHIELD, Heat
0135	690941	4	NUT
0140	690970	2	GASKET, Exhaust
0150	703185	4	BOLT, Round Head, Short Square Neck
0160	703115	4	NUT
0170	327290MA	1	HOSE, Fuel
0180	93053	2	CLAMP, Hose
0190	1759205YP	1	CONTROL-THROTTLE
0210	1739312YP	1	KNOB, THROTTLE
0220	797483	1	SCREW
0230	703460	1	NUT, Hex #8-32
0280	1759429AYP	1	PANEL, Control
0290	705876	3	NUT
0310	703953	5	SCREW, 1/4-20X5/8
0340	797420YP	1	GUARD, Debris Screen
0350	799359	1	SCREW
0380	5025155SM	1	WASHER, 5/16
0390	5025392SM	1	NUT, Ny Lock Flange, 5/16-18
0400	5025011X14SM	1	BOLT, 5/16-18 X 1-3/4

Footnotes:

Note:* Verify your specific engine model, reference the ID Tag located on your engine. Refer to your local Briggs & Stratton distributor for parts and service.

EVAP Group

Note: Unless noted otherwise, use the standard torque specifications

Mfg. No: 5902144

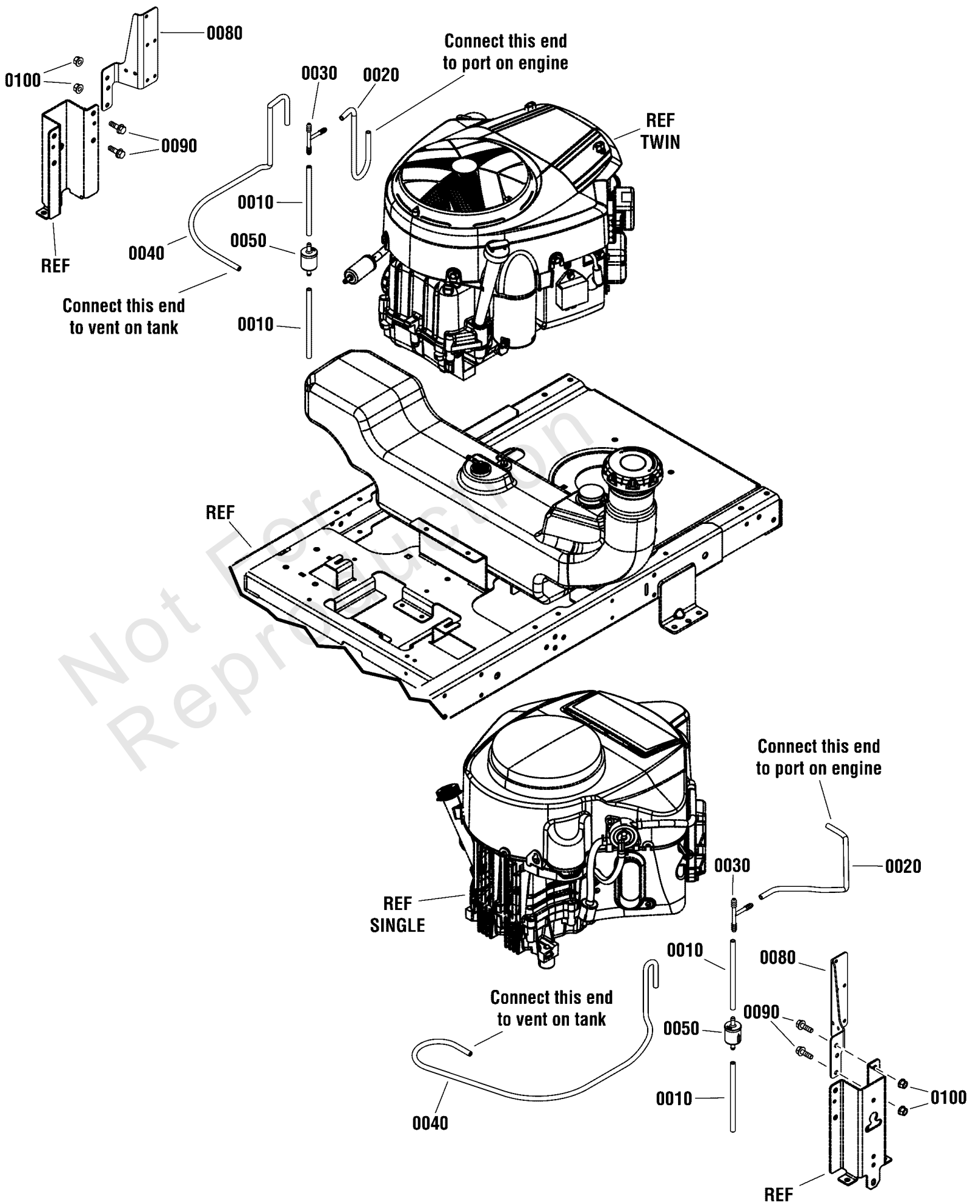

EVAP Group

REF NO	PART NO	QTY	DESCRIPTION
0010	7700552X6YP	2	HOSE-VAPOR
0020	7700552X12YP	1	HOSE, VAPOR,5MM ID,12
0030	5103062YP	1	FITTING, 3/16" TEE, B
0040	7700552X26YP	1	HOSE, Vapor, 5 MM ID, 26.00 LG
0050	84001895	1	FILTER, Fuel
0070	5021030SM	5	TIE WRAP, 5-1/2" LONG -(Not Shown)
0080	1760538AYP	1	BRACKET
0090	703410	2	BOLT,5/16-18X1
0100	703115	2	NUT

Not For Reproduction

Frame Group

Note: Unless noted otherwise, use the standard torque specifications

Mfg. No: 5902144

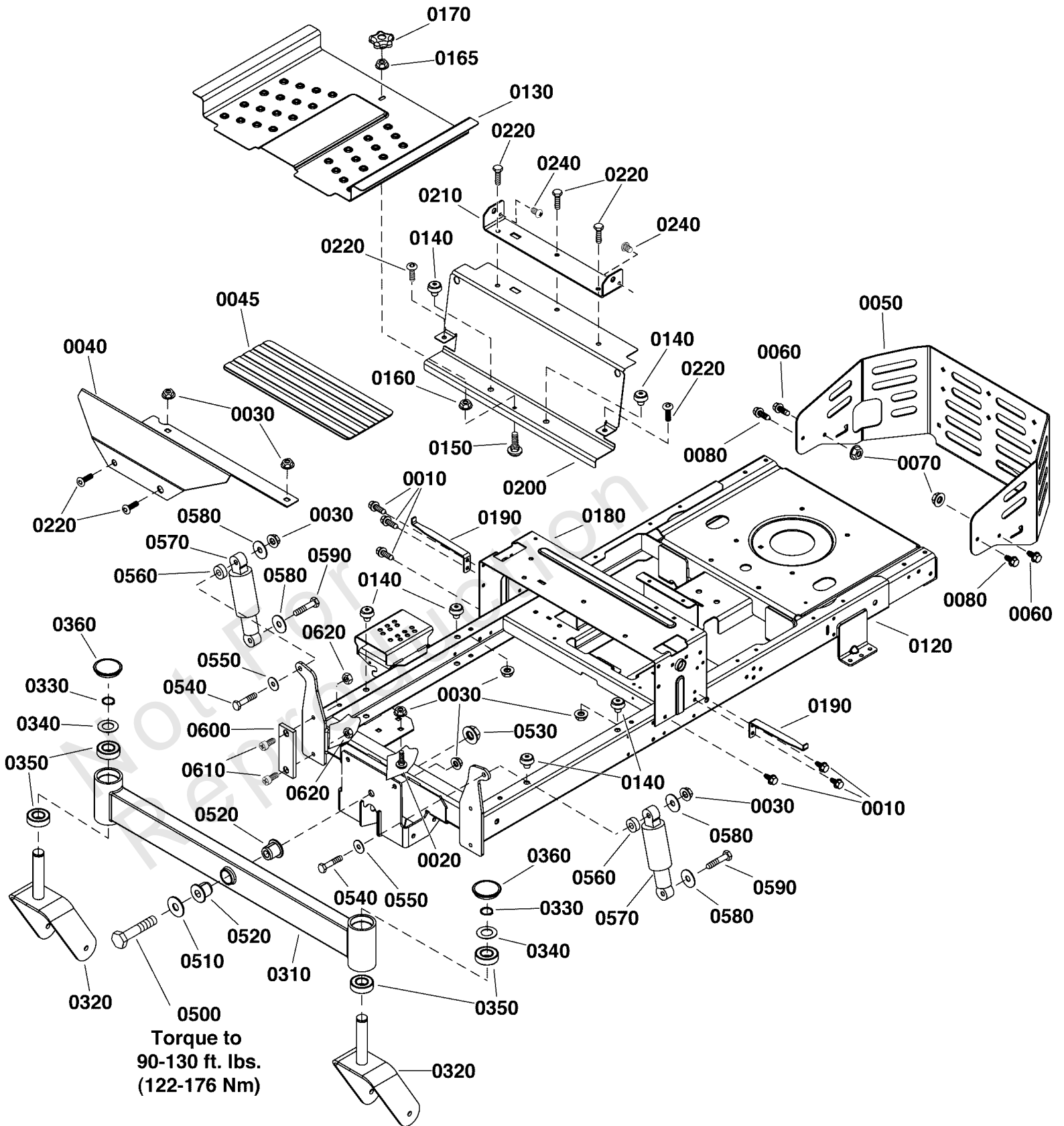

Frame Group

REF NO	PART NO	QTY	DESCRIPTION
0010	703949	6	SCREW, 5/16-18.625
0020	703448	2	BOLT, 3/8-16X.75 G5
0030	703158	13	NUT, Hex Flange, 3/8-16
0040	1759278BYP	1	FOOTREST
0045	5101374YP	1	SAFETY WALK, FLOOR RE
0050	1759501BYP	1	BUMPER, Rear
0060	703410	2	BOLT,5/16-18X1
0070	703115	2	NUT
0080	1664847CAYP	2	SCREW, Hex Washer Head, Taptite, 5/16-18 x 3/4
0120	-----	1	FRAME , Pivot & Suspension -(Not a serviceable part)
0130	5601480	1	FOOT PAN W/ DECAL
0140	197546GS	6	MOUNT-VIBRATION
0150	7090496YP	1	RHSSNB, 1/4C X1 GR5 Z
0160	7091584SM	1	NUT, Serrated Flange,1/4-20, GR5
0165	703954	1	NUT, Centerlock, 1/4-20, GR5
0170	707785	1	KNOB
0180	80096436BFS	1	BRACKET, CONTROL
0190	1758240AYP	2	BRACKET, Fender
0200	1757796BYP	1	PLATE-DECAL
0210	84001640	1	SUPPORT, Seat
0220	707790	7	SCREW, Button Head, 3/8-16 X .88
0240	703932	2	SCREW, 5/16-18X.5
0310	84001641	1	AXLE ASSEMBLY
0320	80081658BFS	2	CASTER
0330	703993	2	RETAINER, EXT RING, 1
0340	703199	2	WASHER, 1
0350	1758354YP	4	BEARING
0360	1725651SM	2	COVER, Spindle
0360	5105524YP	2	CAP
0500	707789	1	BOLT
0510	1960035SM	2	WASHER-0.625(0.64IDX1
0520	1759234YP	2	BUSHING
0530	2860646SM	1	NUT, Hex Flange, 5/8-11
0540	703589	2	CAPSCREW, 3/8-16X2
0550	71072MA	2	WASHER, FLAT .406X.81
0560	1667811SM	2	SPACER
0570	1755279YP	2	SHOCK ABSORBER, 8IN
0580	5025165SM	4	WASHER, 3/8" FENDER
0590	703406	2	CAPSCREW,3/8-16X1.5
0600	1759391YP	2	PAD-FRICTION
0610	5025594YP	4	SCREW, 5/16-18 X 1
0620	5025057SM	4	NUT, Hex Lock, 5/16-18

Lift Group

Note: Unless noted otherwise, use the standard torque specifications

Mfg. No: 5902144

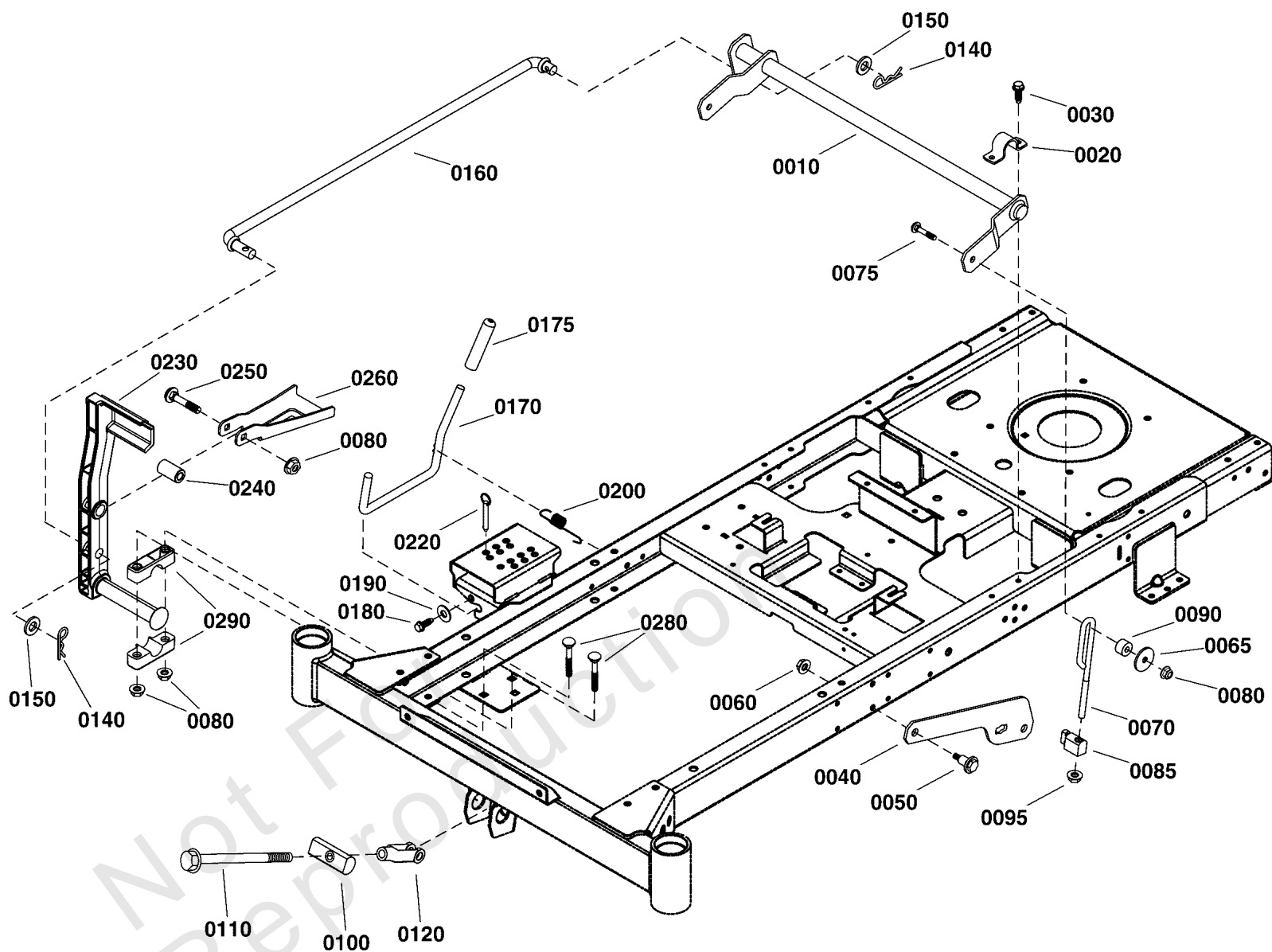

Lift Group

REF NO	PART NO	QTY	DESCRIPTION
0010	1757958AYP	1	SHAFT
0020	1720147BZYP	2	STRAP, 1 IN. DIA
0030	703949	4	SCREW, 5/16-18.625
0040	1757953AYP	2	ARM, Lift
0050	1732426SM	2	BOLT-SHLDR 5/16-18 0.
0060	703115	2	NUT
0065	5025305SM	2	WASHER, .41 X 1.75 X
0070	84003818	2	ROD, Lift
0075	703406	2	CAPSCREW,3/8-16X1.5
0080	703158	7	NUT, Hex Flange, 3/8-16
0085	84003820	2	TRUNNION
0090	5100334SM	2	SPACER
0095	770225	2	NUT
0100	1757955YP	1	PIVOT
0110	1757954YP	1	ROD
0120	5023174SM	1	CLEVIS, 1/2-20, STEEL
0140	403162MA	2	PIN, Hair, 3/32 X 1.6
0150	5025281SM	2	WASHER, 5/8" SAE
0160	1758121YP	1	ROD
0170	5105717YP	1	ROD
0175	5021880SM	1	GRIP, FOAM
0180	703054	2	SCREW, 1/4-20X0.625
0190	5025288YP	2	WASHER, 1/4 FENDER
0200	1758283YP	1	SPRING, EXTENSION
0220	5103021YP	1	HITCH PIN, 3/8 X 2-1/
0230	1758232YP	1	PEDAL
0240	1756612YP	1	BUSHING, DIFF. LOCK
0250	7900009SM	1	RHSSNB, 3/8-16 X 2-1/
0260	1758284AYP	1	BRACKET
0280	1960615SM	4	BOLT-RD HD SQ NK 3/8
0290	5100634SM	4	PIVOT BLOCK, PLASTIC

Parking Brake Group (2991641)

Note: Unless noted otherwise, use the standard torque specifications

Mfg. No: 5902144

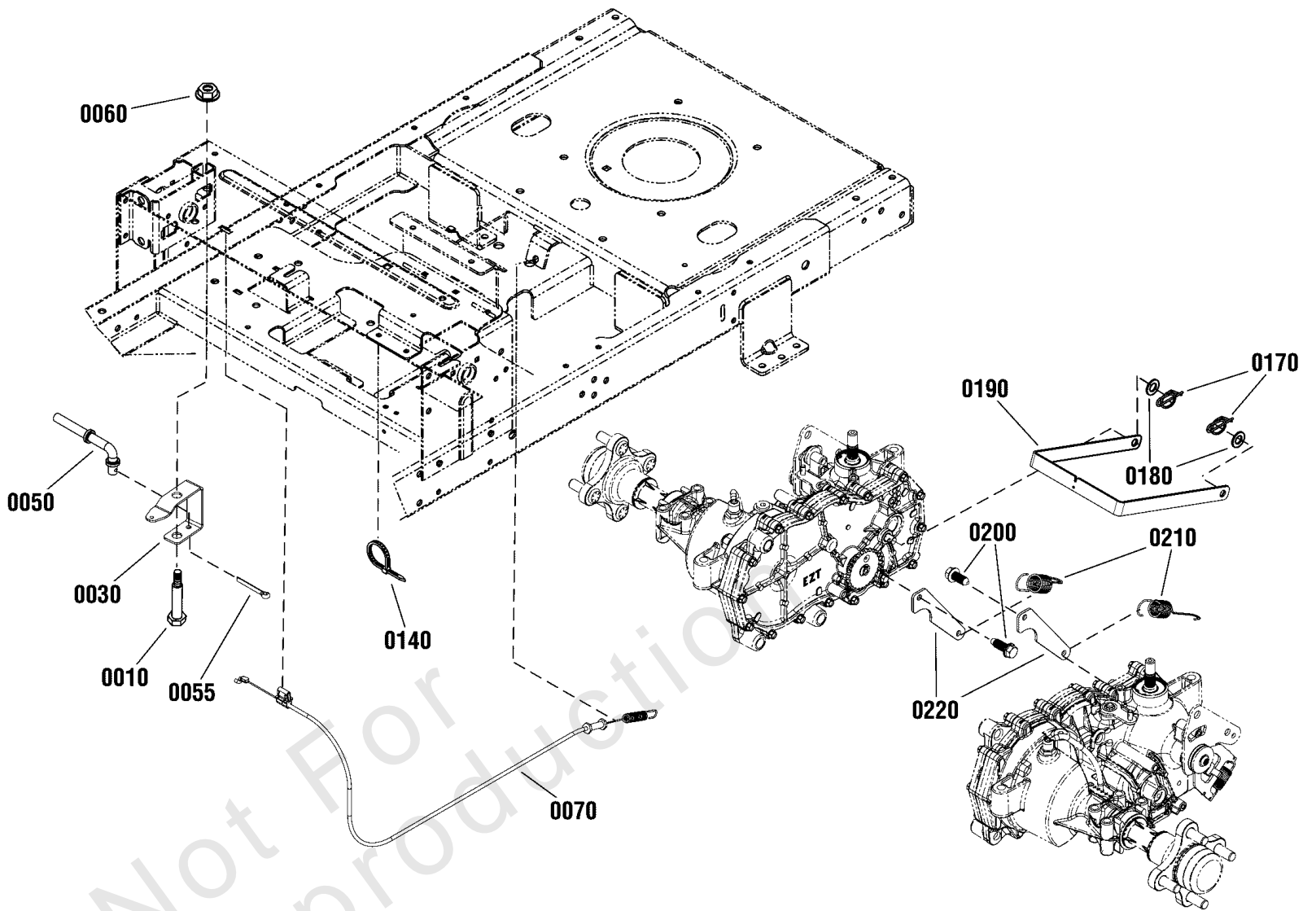

Parking Brake Group (2991641)

REF NO	PART NO	QTY	DESCRIPTION
0010	1736539YP	1	BOLT, SHOULDER
0030	1758091YP	1	BELLCRANK, Parking Brake
0050	1758088YP	1	ROD, Parking Brake
0055	703312	1	PIN, COTTER, 3/32X.75
0060	703158	1	NUT, Hex Flange, 3/8-16
0070	1759207YP	1	CABLE, PARKING BRAKE
0140	703586	1	TIE, SELF LOCKING
0170	7091594SM	2	COTTER PIN, 1/2 SELF,
0180	703946	2	WASHER, .39IDX.72OD
0190	1758126AYP	1	ARM, Parking Brake
0200	708964	2	SCREW
0210	1758283YP	2	SPRING, EXTENSION
0220	1759349YP	2	BRACKET, Spring

Not For Reproduction

Seat Group

Note: Unless noted otherwise, use the standard torque specifications

Mfg. No: 5902144

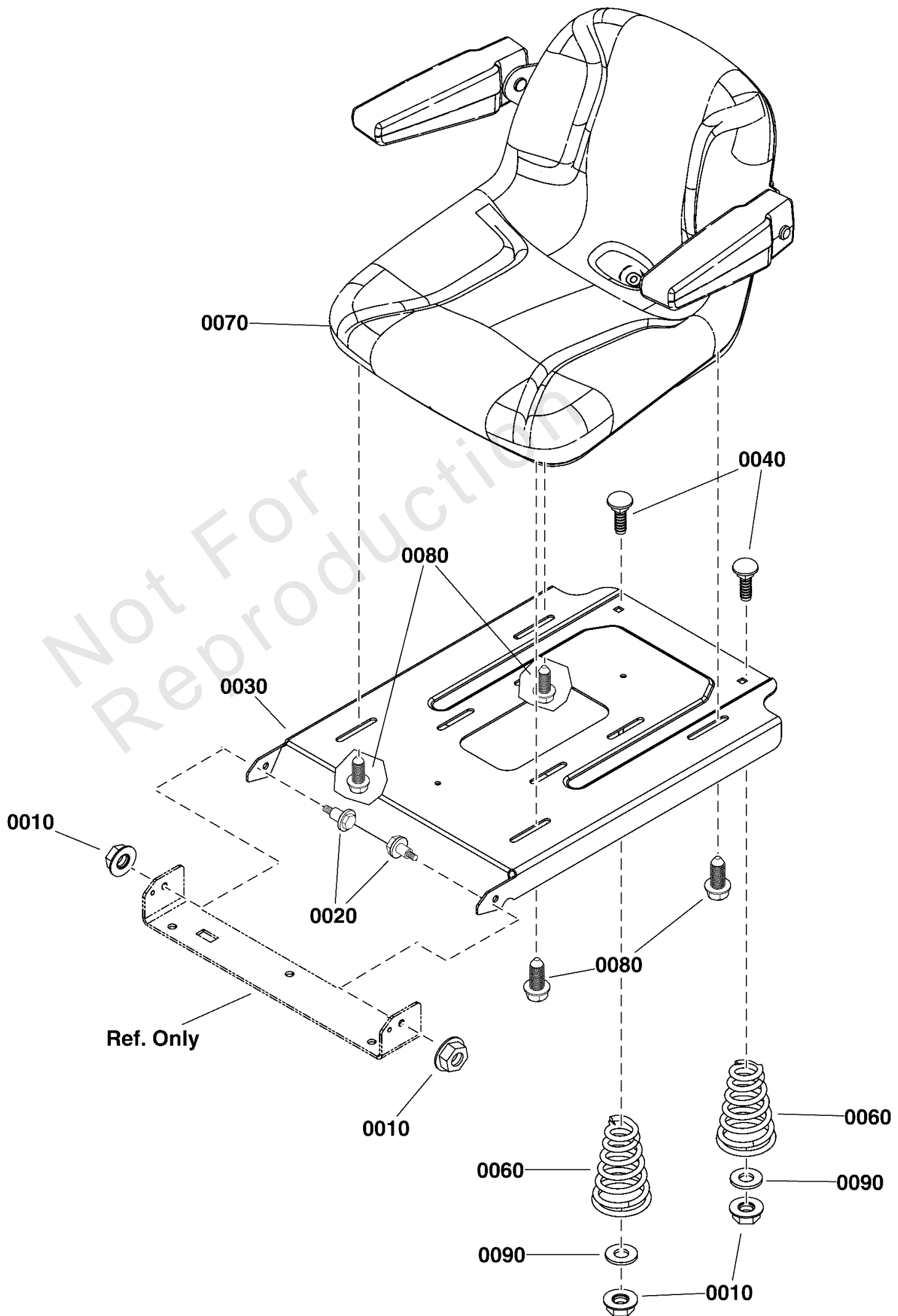

Seat Group

REF NO	PART NO	QTY	DESCRIPTION
0010	5025392FS	4	NUT
0020	1752802YP	2	BOLT, SHLDR, 5/16-18
0030	84001620	1	SLIDE, SEAT
0040	703483	2	BOLT,5/16-18X1.000,RO
0060	1717051SM	2	SPRING, Seat
0070	84003851	1	SEAT ASSEMBLY w/Armrests -(S/N: 4002340028 and Below)
0070	84010949	1	SEAT ASSEMBLY w/Arm Rests -(S/N: 4002340029 and Above)
0080	1960667SM	4	SCREW-HEX WZ LOCK FLN
0090	703591	4	WASHER, .406X1.5X.12

Not For Reproduction

Transaxle Service Parts - 84008002 & 84007995

Note: Unless noted otherwise, use the standard torque specifications

Mfg. No: 5902144

Service Parts Schematic for Hydro-Gear® Transaxles:

ZD-AUBB-2A7B-3XPX (84008002)

ZD-DUBB-2A7C-2XPX (84007995)

For components not listed see your authorized Hydro-Gear® service provider.

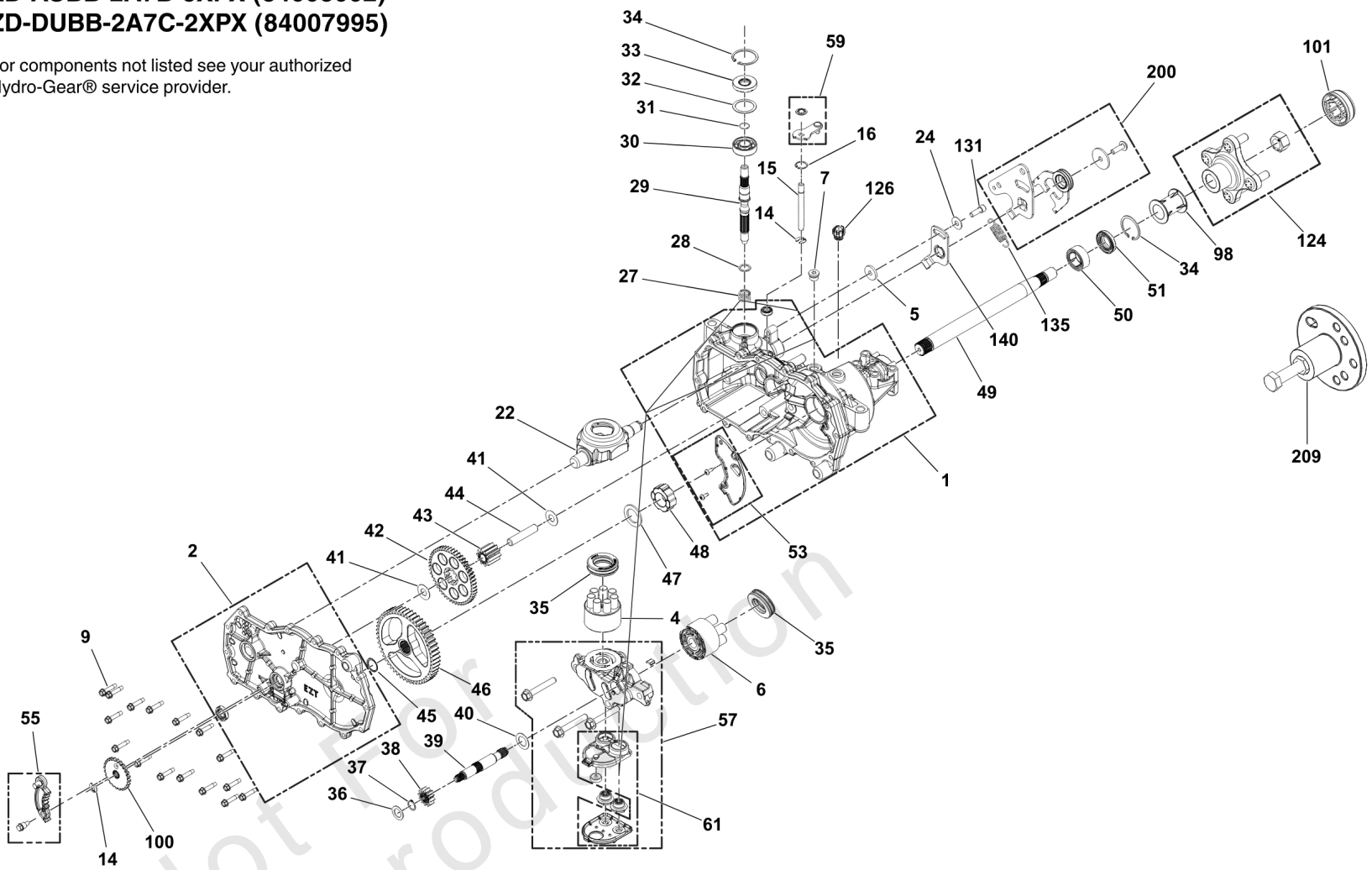

Transaxle Service Parts - 84008002 & 84007995

REF NO	PART NO	QTY	DESCRIPTION
1	-----	1	KIT, Housing Main, RH
2	-----	1	KIT, Housing, Side RH
4	-----	1	KIT, BLOCK 7 PISTON
5	-----	1	SPACER, .320X1.005X.179
6	5023417SM	1	Cylinder Block Kit
7	-----	1	PLUG, 9/16-18 STR THREAD SOCKET HEAD
9	-----	16	SCREW, HEX WASHER
14	-----	2	BYPASS RETAINING RING 1
15	-----	1	ROD, BYPASS
16	-----	1	BYPASS RETAINING RING 2
19	-----	1	SWASHPLATE, TRUNNION
24	-----	1	WASHER, .34X.88X.06
27	1715171SM	1	SPRING - HELICAL COMPRESSION
28	1715172SM	1	WASHER, Block Thrust
29	-----	1	SHAFT, Input
30	1730274SM	1	BALL BRG 17MM ID X 40MM OD X 12MM
31	-----	1	RING RET 67 EXT WIRE
32	1730272	1	SPACER (50951)
33	5023414	1	Lip Seal 17 x 40 x 7 PTC
33	5101026X3	1	SEAL, LIP, 17 X 40 X 7
34	5023415	2	Spacer
34	5101026X4	2	RING, RET 2.06 INT,
35	-----	2	BEARING, THRUST 30 x 52 x 13
36	-----	1	WASHER, .63 X 1.00 X .05 FLAT
37	1706130	1	RING-SNAP (44145)
38	-----	1	GEAR-PINION, 12T
39	-----	1	SHAFT, MOTOR
40	-----	1	WASHER, .71 X 1.16 X .04 FLAT
41	-----	2	WASHER, .51 X 1.00 X .03 FLAT
42	-----	1	GEAR, 49T/10T
43	-----	1	GEAR, 10T JACKSHAFT
44	-----	1	PIN, JACKSHAFT
45	-----	1	RING, SPIRAL RETAINING-87
46	-----	1	GEAR, BULL 52T
47	-----	1	WASHER, 1.018 X 1.571 X .105 FLAT
48	-----	1	BUSHING, SLEEVE (INBOARD)
49	-----	1	SHAFT, AXLE
50	-----	1	BUSHING, 1.003 x 1.571 x .625
51	-----	1	SEAL, LIP, TC4 1.00 X 1.577 X .27
52	1728060SM	1	KIT, Hydro Seal
53	-----	1	KIT, EXPANSION PLATE RH
55	1728075SM	1	ASSEMBLY, Parking Brake Arm, Transmission
57	-----	1	KIT, CENTER SECTION, W/FILTER - RH
58	-----	1	TUBE, SEALANT
59	-----	1	KIT, BYPASS ARM

Transaxle Service Parts - 84008002 & 84007995

Note: Unless noted otherwise, use the standard torque specifications

Mfg. No: 5902144

Service Parts Schematic for Hydro-Gear® Transaxles:

ZD-AUBB-2A7B-3XPX (84008002)

ZD-DUBB-2A7C-2XPX (84007995)

For components not listed see your authorized Hydro-Gear® service provider.

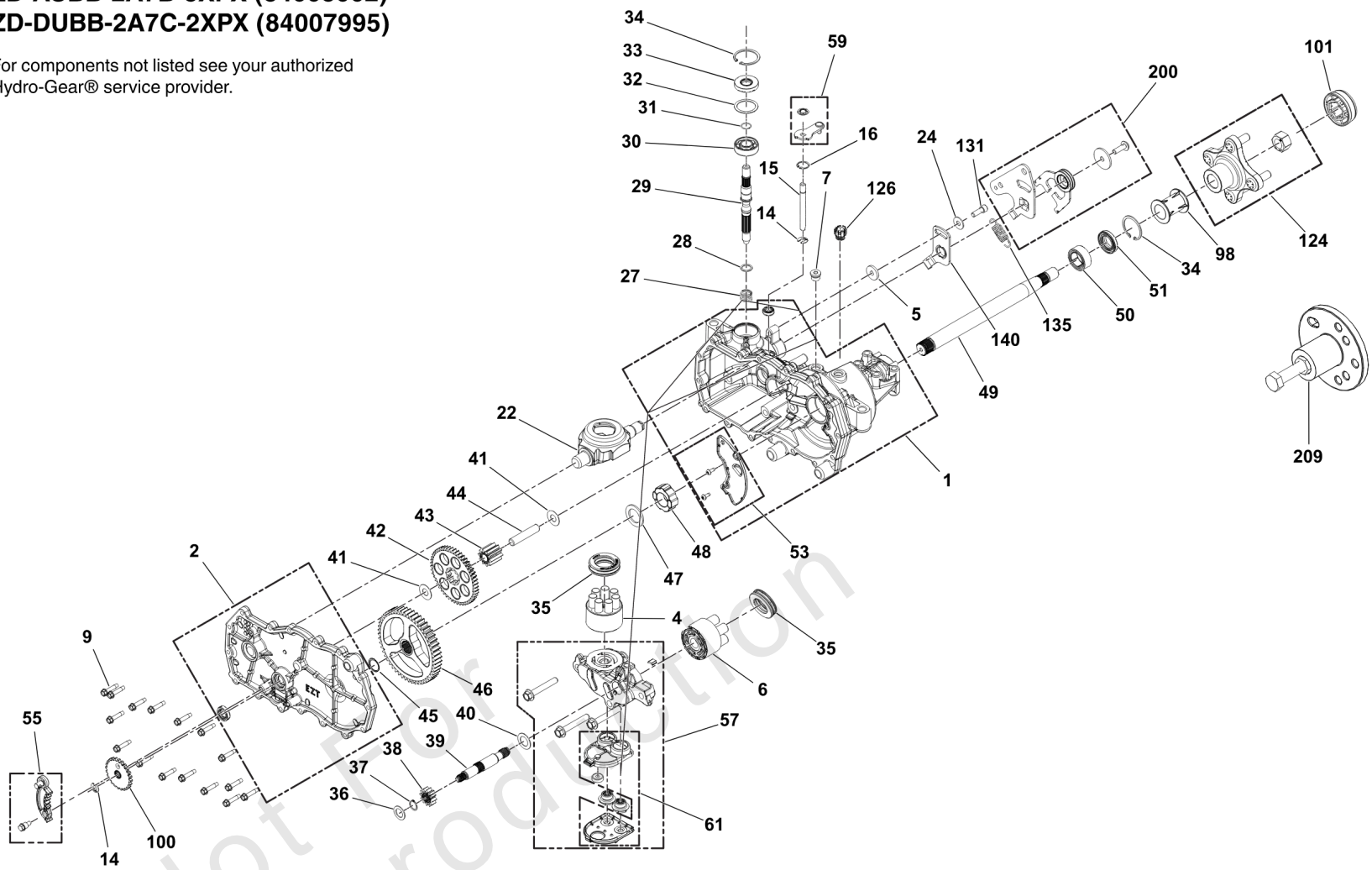

Transaxle Service Parts - 84008002 & 84007995

REF NO	PART NO	QTY	DESCRIPTION
61	-----	1	KIT, FILTER
98	-----	1	TUBE, AXLE 1.835
100	1728076SM	1	GEAR, Parking Brake, Transmission
101	5103589X7	1	AXLE CAP,
124	5103589X8	1	ASSM, HUB
126	-----	1	ASSEMBLY, FITTING 9/16-18 BREATHER
131	-----	1	KIT, RTN SCREWS
135	5101026X19	1	SPRING, EXTENSION (52401)
140	-----	1	ARM, NEUTRAL RIGHT
200	1735491SM	1	ARM, Control Kit R.H.
209	-----	1	KIT, HUB PULLER

Not For Reproduction

Transmission Group

Note: Unless noted otherwise, use the standard torque specifications

Mfg. No: 5902144

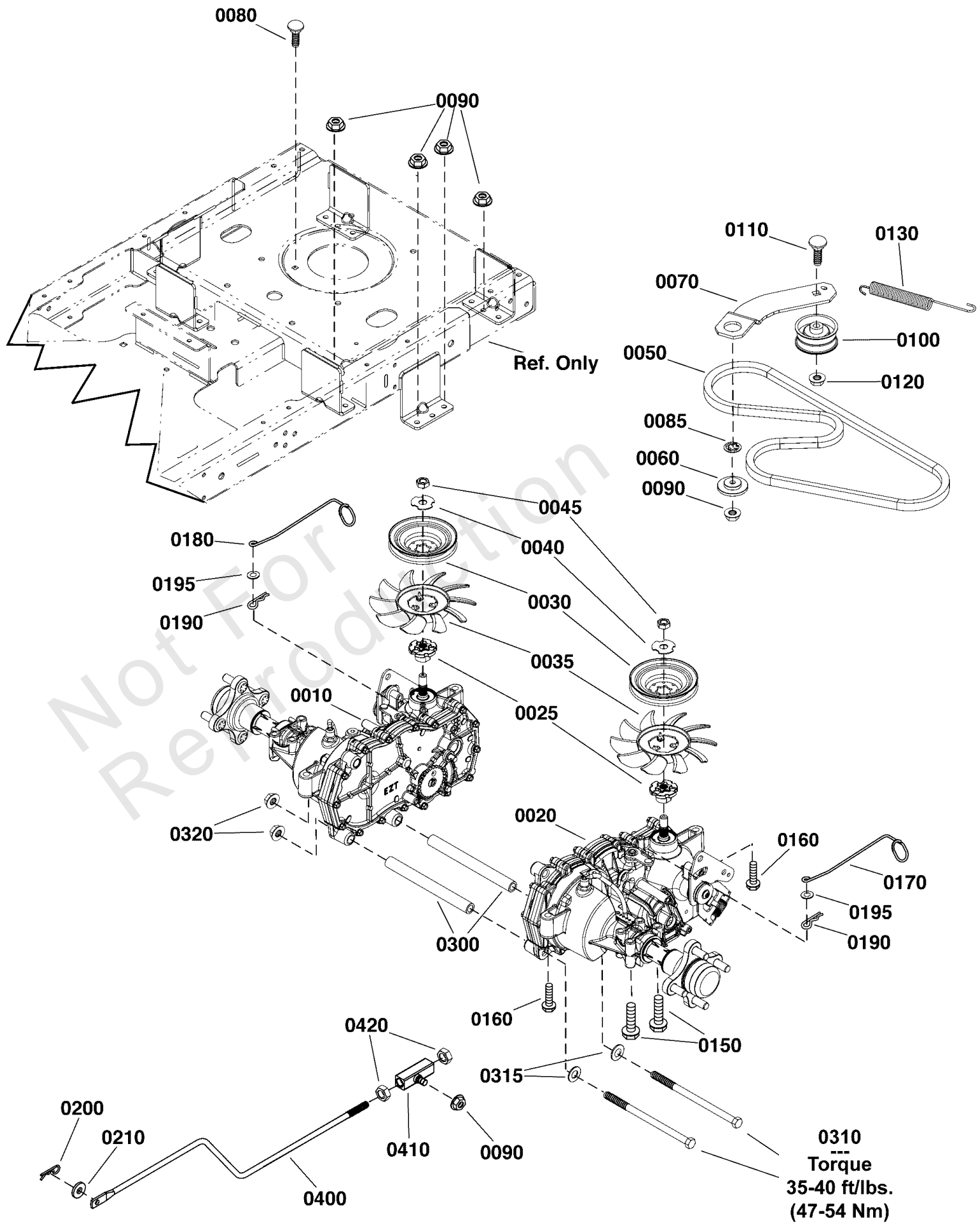

Transmission Group

REF NO	PART NO	QTY	DESCRIPTION
0010	84007995	1	TRANSAXLE -(Right side)(Refer to Note: *)
0020	84008002	1	TRANSAXLE -(Left side)(Refer to Note: *)
0025	1759450YP	2	SPACER
0030	1759447YP	2	PULLEY, Transmission
0035	1759448YP	2	FAN, Input
0040	5102914YP	2	WASHER, ZT5400, SLOTT
0045	5102916YP	2	NUT, ZT5400
0050	1758100YP	1	BELT-TRANSMISSION
0060	1727935SM	1	SPACER-PIVOT 0.330ID
0070	1758044AYP	1	ARM, Idler
0080	703800	1	BOLT, CRRG, 5/16-18X1
0085	703297	1	RETAINER, GR5, 5/16
0090	703115	11	NUT
0100	1668477SM	1	PULLEY, Idler, 2.25" OD, .378 ID
0110	703879	1	BOLT, SQ, 3/8-16X1.75
0120	703158	1	NUT, Hex Flange, 3/8-16
0130	1758045YP	1	SPRING-EXTENSION
0150	707943	4	SCREW
0160	707944	4	SCREW, Washer Head, 5/16-18 X 2 1/4
0170	1759245YP	1	ROD, Release, LH
0180	1759246YP	1	ROD, Release, RH
0190	703430	2	PIN, 13X1.19
0195	703332	2	WASHER
0200	703300	2	PIN, 3/32 X 1.6
0210	704128	2	WASHER
0300	1759392YP	2	SPACER, Transmission
0310	707945	2	CAPSCREW, HexHead, 7/16-14 X 11 1/4
0315	703183	2	WASHER, 7/16 ID X.065
0320	1930650SM	2	NUT-HEX FLANGE 7/16-1
0400	84002180	2	CONTROL ROD, Transmission
0410	84002181	2	TRUNNION
0420	7090460SM	4	NUT, 7/16F, GR5, Hex

Footnotes:

Note: *See your local Hydro Gear dealer for parts and service.

Wheel & Tire Group

Note: Unless noted otherwise, use the standard torque specifications

Mfg. No: 5902144

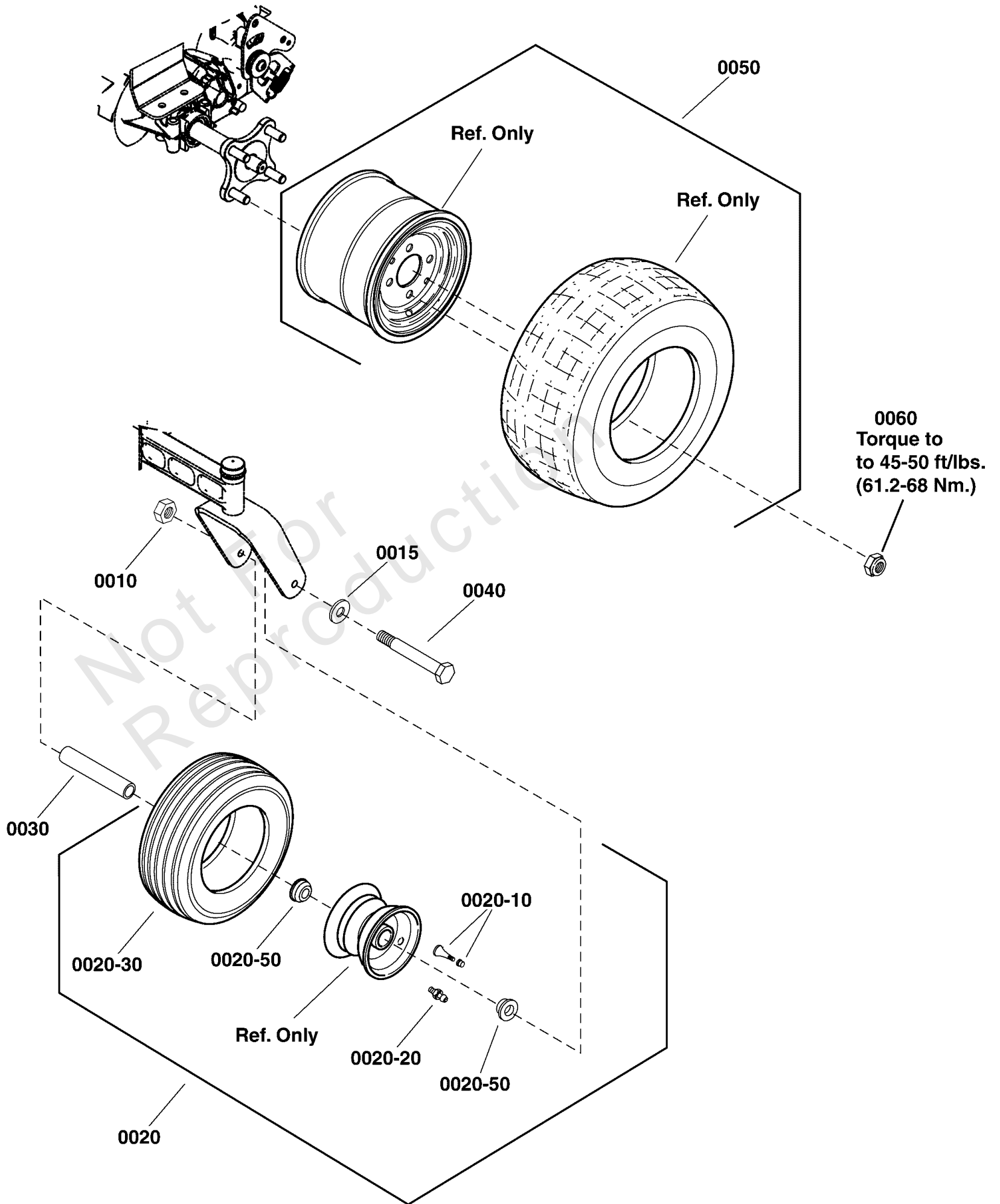

Wheel & Tire Group

REF NO	PART NO	QTY	DESCRIPTION
0010	1930650SM	2	NUT-HEX FLANGE 7/16-1
0015	703183	2	WASHER, 7/16 ID X.065
0020	5109054FS	2	TIRE ASSEMBLY
0020-10	2172353SM	4	VALVE STEM & CAP
0020-20	7104428YP	2	ZERK, Grease
0020-30	84004709	2	TIRE
0020-50	84003829	4	BEARING, BALL
0030	80081657FS	2	TUBE
0040	84003828	2	CAPSCREW
0050	84008368	2	TIRE ASSEMBLY
0060	5020601SM	8	NUT, 1/2-20, FOR WHEEL BOLT SILVER

Not For Reproduction

Hardware Identification & Torque Specifications

Torque Specification Chart								
FOR STANDARD METRIC MACHINE HARDWARE (Tolerance ± 20%)								
Property Class	5.6		8.8		10.9		12.9	
	Class 5.6		Class 8.8		Class 10.9		Class 12.9	
Size Of Hardware	in/lbs	Nm.	in/lbs	Nm.	in/lbs	Nm.	in/lbs	Nm.
	ft/lbs		ft/lbs		ft/lbs		ft/lbs	
M3	5.88	.56	13.44	1.28	19.2	1.80	22.92	2.15
M4	13.44	1.28	30.72	2.90	43.44	4.10	52.56	4.95
M5	26.4	2.50	60.96	5.75	5.97	8.10	7.15	9.7
M6	44.64	4.3	7.3	9.9	10.3	14	12.1	16.5
M7	5.2	7.1	12.1	16.5	16.9	23	19.9	27
M8	7.7	10.5	17.7	24	25	34	29	40
M10	15	21	35	48	50	67	59	81
M12	26	36	61	83	86.2	117	103	140
M14	42	58	101	132	136	185	162	220
M16	64	88	147	200	210	285	250	340
M18	89	121	202	275	287	390	346	470
M20	126	171	290	390	405	550	486	660
M22	169	230	390	530	559	745	656	890
M24	217	295	497	375	708	960	840	1140
M27	320	435	733	995	1032	1400	1239	1680
M30	435	590	995	1350	1401	1900	1681	2280
M33	590	800	1349	1830	1902	2580	2278	3090
M36	759	1030	1740	2360	2441	3310	2935	3980
M39	988	1340	2249	3050	3163	4290	3798	5150

Torque Specification Chart						
FOR STANDARD MACHINE HARDWARE (Tolerance ± 20%)						
Hardware Grade	No Marks		SAE Grade 5		SAE Grade 8	
	SAE Grade 2		SAE Grade 5		SAE Grade 8	
Size Of Hardware	in/lbs	Nm.	in/lbs	Nm.	in/lbs	Nm.
	ft/lbs		ft/lbs		ft/lbs	
8-32	19	2.1	30	3.4	41	4.6
8-36	20	2.3	31	3.5	43	4.9
10-24	27	3.1	43	4.9	60	6.8
10-32	31	3.5	49	5.5	68	7.7
1/4-20	66	7.6	8	10.9	12	16.3
1/4-28	76	8.6	10	13.6	14	19.0
5/16-18	11	15.0	17	23.1	25	34.0
5/16-24	12	16.3	19	25.8	29	34.0
3/8-16	20	27.2	30	40.8	45	61.2
3/8-24	23	31.3	35	47.6	50	68.0
7/16-14	30	40.8	50	68.0	70	95.2
7/16-20	35	47.6	55	74.8	80	108.8
1/2-13	50	68.0	75	102.0	110	149.6
1/2-20	55	74.8	90	122.4	120	163.2
9/16-12	65	88.4	110	149.6	150	204.0
9/16-18	75	102.0	120	163.2	170	231.2
5/8-11	90	122.4	150	204.0	220	299.2
5/8-18	100	136	180	244.8	240	326.4
3/4-10	160	217.6	260	353.6	386	525.0
3/4-16	180	244.8	300	408.0	420	571.2
7/8-9	140	190.4	400	544.0	600	816.0
7/8-14	155	210.8	440	598.4	660	897.6
1-8	220	299.2	580	788.8	900	1,244.0
1-12	240	326.4	640	870.4	1,000	1,360.0

The guides and ruler furnished below are designed to help you select the appropriate hardware.



Nut, M8

Thread Diameter (mm)

Inside Diameter (in) Threads per inch

Nut, 1/2-16



Screw, M8- 1.25 x 25

Thread Diameter (mm) Distance between threads (mm) Body Length (mm)

Body Diameter Threads per inch Body Length (in)

Screw, 1/2- 16 x 2



Standard Hardware Sizing

When a washer or nut is identified as 1/2" (M8), this is the *Nominal size*, meaning the *inside diameter* is 1/2 inch (8mm metric thread diameter); if a second number is present it represents the *threads per inch* (distance between threads).

When bolt or capscrew is identified as 1/2 - 16 x 2" (M8 - 1.25 x 50), this means the *Nominal size*, or body diameter is 1/2 inch (8mm metric thread diameter), the second number, 16, represents the *threads per inch*, (*distance between threads*). The final number is the body length of the bolt or screw, 2 inches (50mm).

NOTES

- These torque values are to be used for all hardware excluding: locknuts, self-tapping screws, thread forming screws, sheet metal screws and socket head setscrews.
- Recommended seating torque values for locknuts:
 - for prevailing torque locknuts - use 65% of grade 5 torques.
 - for flange whizlock nuts and screws - use 135% of grade 5 torques.
- Unless otherwise noted on assembly drawings, all torque values must meet this specification.

Common Hardware Types

Hex Head Capscrew



Washer



Carriage Bolt



Hex Nut

Wrench & Fastener Size Guide

1/4" Bolt or Nut Wrench—7/16"	5/16" Bolt or Nut Wrench—1/2"	3/8" Bolt or Nut Wrench—9/16"	7/16" Bolt or Nut Wrench (Bolt)—5/8" Wrench (Nut)—11/16"	1/2" Bolt or Nut Wrench—3/4"
M6 Bolt or Nut Wrench—10mm	M8 Bolt or Nut Wrench—13mm	M10 Bolt or Nut Wrench—17mm	M12 Bolt or Nut Wrench—19mm	M14 Bolt or Nut Wrench—22mm

