



# Parts Manual

Mfg. No: 5902052  
500S Series w/ 52" Mower Deck  
(500SB2552)



1696384YP - Grass Mulcher Kit, 52" Fabricated Mower Deck. ....

5601077 - Service Jack Mount Kit (10"). ....

5601080 - Service Jack Kit. ....

5601391 - Kit, 2-Bag Clean Sweep, Turbo, 500S-52. ....

Not For  
Reproduction

<b>Model Components</b>	<b>Page</b>
52" Mower Deck - Housing, Arbors & Blade Group.....	4
52" Mower Deck - Pulleys, Belt, and Idler Arm.....	6
Body & Fuel Tank Group.....	8
Controls Group.....	10
Decal Group - Brand and Model.....	12
Decal Group - Safety and Operation.....	14
Electrical Group.....	16
Electrical Schematic - Charging Circuit - B&S 44C777 & 44T977.....	18
Electrical Schematic - Cranking Circuit - B&S 44C777 & 44T977.....	20
Electrical Schematic - Ignition Grounding Circuit/Op. Pres. - B&S 44C777 & 44T977.....	22
Electrical Schematic - PTO Clutch Circuit - B&S 44C777 & 44T977.....	24
Engine and PTO Group.....	26
EVAP Group.....	28
Frame, Pivoting Front Axle, Floor Pan, and Bumper Group.....	30
Lift Group.....	32
Parking Brake Group.....	34
Rear Suspension Group.....	36
Seat Group - S/N: 4002363335 and Below.....	38
Seat Group - S/N: 4002363336 and Above.....	40
Transaxle Service Parts - 84008004 & 84007997.....	42
Transmission Group - Suspension.....	46
Wheel & Tire Group.....	48
Torque Specification Chart.....	50

# 52" Mower Deck - Housing, Arbors & Blade Group

Note: Unless noted otherwise, use the standard torque specifications

Mfg. No: 5902052

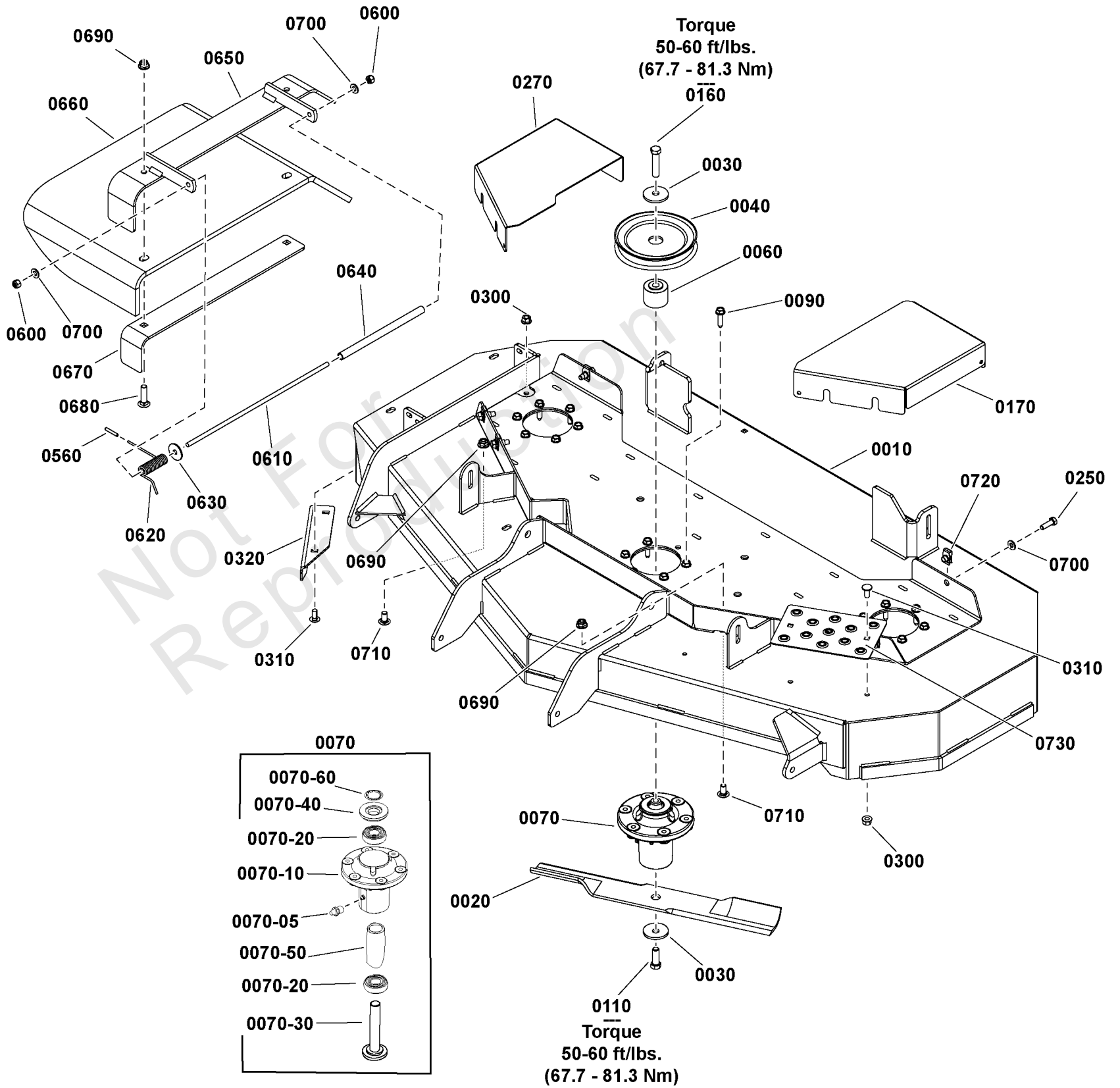

## 52" Mower Deck - Housing, Arbors & Blade Group

REF NO	PART NO	QTY	DESCRIPTION
0010	5601356	1	DECK SHELL W/DECALS, 500S-52 (80092013B)
0020	1756152S	1	BLADE, 18", SET OF THREE (3)
0030	1656916SM	6	WASHER, SPRING 0.475I
0040	84006898	3	PULLEY
0060	1759940YP	3	SPACER
0070	84003174	3	ARBOR ASSEMBLY
0070-05	703907	1	ZERK, FITTING, 1/4
0070-10	84003653	1	HOUSING ASSEMBLY
0070-20	1735399YP	2	BEARING, Ball, 20mm
0070-30	1761746	1	SHAFT, MOWER SPINDLE-.620 BLADE PILOT
0070-40	84003166	1	COVER, ARBOR
0070-50	84003167	1	SPACER, BEARING
0070-60	1960766YP	1	RING, SELF LOCKING
0090	80003681	18	SCREW, Hex Washer Head Taptite 5/16-18 x 1-1/4
0110	703579	3	HHCS, 7/16-14X1.25
0160	84007038	3	CAPSCREW, Hex Head, 7/16-14 X 2
0170	84007039	1	COVER, ARBOR
0250	5025011X6SM	6	BOLT, 5/16-18 X 3/4"
0270	84006931	1	COVER, ARBOR
0300	5025392FS	4	NUT
0310	5025145X6SM	4	BOLT, 5/16-18 X 3/4",
0320	5405557AAFS	1	PLATE
0560	5023489SM	1	CAP, PROTECTOR, .120
0600	5025045SM	2	NUT, 5/16-24 HEX NYLO
0610	5042555SM	1	ROD, BRAKE LINKAGE
0620	5023385SM	1	SPRING, TORSION
0630	5025164SM	1	WASHER, 5/16" FENDER
0640	5050086X8SM	1	TORSION SPRING SPACER
0650	5413404AAFS	1	MOUNT
0660	5413498	1	CHUTE, RUBBER DISCHARGE CHUTE (5104441)
0670	5413401AYP	1	SUPPORT
0680	5025146X12YP	2	BOLT, 3/8-16 X 1-1/2
0690	5025394SM	4	NUT, 3/8-16 HEX NYLOCK
0700	703350	8	WASHER
0710	703448	2	BOLT, 3/8-16X.75 G5
0720	5022308SM	6	BODY CLIP, 5/16-18 X
0730	84006929	1	PLATE, BASE

# 52" Mower Deck - Pulleys, Belt, and Idler Arm

Note: Unless noted otherwise, use the standard torque specifications

Mfg. No: 5902052

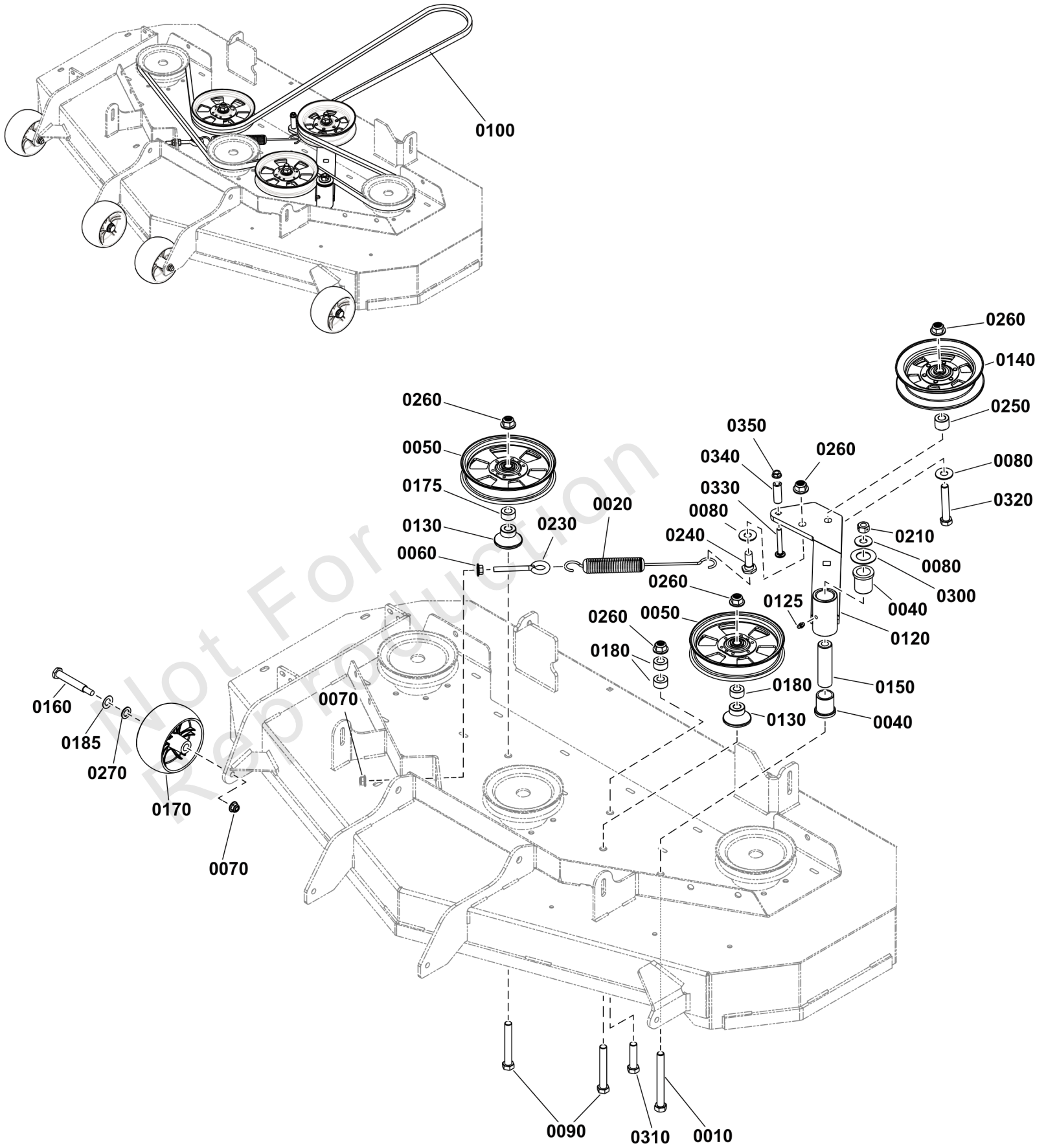

## 52" Mower Deck - Pulleys, Belt, and Idler Arm

REF NO	PART NO	QTY	DESCRIPTION
0010	5025017X36	1	BOLT, 1/2-13 X 4-1/2" GD5 YZ
0020	5023340	1	SPRING-EXT, 1.04 ODX10.535LGX.148WR, BLK
0040	5021541	2	BUSHING, FLANGE
0050	5104717	2	PULLEY, FLT IDLR, 6.0 X 1.0 X .50, CZ
0060	5025128	1	NUT, 3/8-16 Hex Large Serrated Flange
0070	5025394	5	NUT, 3/8 - 16 HEX NYLOCK FLANGE
0080	-----	3	WASHER, Flat
0090	5025017X28	2	BOLT, 1/2-13 X 3-1/2, HEX HD, GD5, CZ (SV)
0100	80098314	1	BELT, B SECT, 149.92 EFL - ARAMID
0120	-----	1	WELDMENT, Idler Arm, 52"
0125	5020095	1	GREASE FITTING, 1/4-28 Straight
0130	5103430	2	IDLER MOUNT
0140	5104716	1	PULLEY,IDLER,BACKSIDE,NOSEAM 6.25ODX.5ID
0150	5045022	1	SPACER, .52 x 1.00 x 3.50
0160	1736539	4	SHOULDER BOLT, 3/8-16 x 3.41" .750 Thread Yellow
0170	1736896	4	GAUGE WHEEL, Black Poly 5" Dia.
0175	5101162	1	SPACER, .52 X 1.00 X .56, PM, CZ
0180	5104482	3	SPACER, .52 X 1.00 X .50, CZ
0185	720035	4	WASHER, Spring, .30" ID
0210	5025332	1	NUT, 1/2-13 Hex Side Lock
0230	5025429	1	EYEBOLT, 3/8-16 X 4, 2.13THRD, .75EYE, C
0240	1737409	1	BOLT, Shoulder, 2-9/16 Long
0250	5045178	1	SPACER, .52 X 1.00 X .75, CZ
0260	5025396	5	NUT, Hex Flange, Nylock, 1/2-13
0270	80003590	4	WASHER,.516IDX.875ODX.06,FLAT,ZC/CL
0300	80004282	1	WASHER,1.017IDX1.812ODX0.6THK,FLAT,ZC/CL
0310	5025017X16	1	BOLT, 1/2-13 X 2" GD5 CZ
0320	5025017X24	1	BOLT, 1/2-13 X 3" GD5 CZ
0330	80004285	1	SCREW,RDHD SH SQ NK 5/16 X 2.25, ZC/CL
0340	1713588	1	SPACER, 5/16 ID x 1 Long
0350	-----	1	NUT 5/16-18 HEX FLNG CNTR LCK ZC/CL

# Body & Fuel Tank Group

Note: Unless noted otherwise, use the standard torque specifications

Mfg. No: 5902052

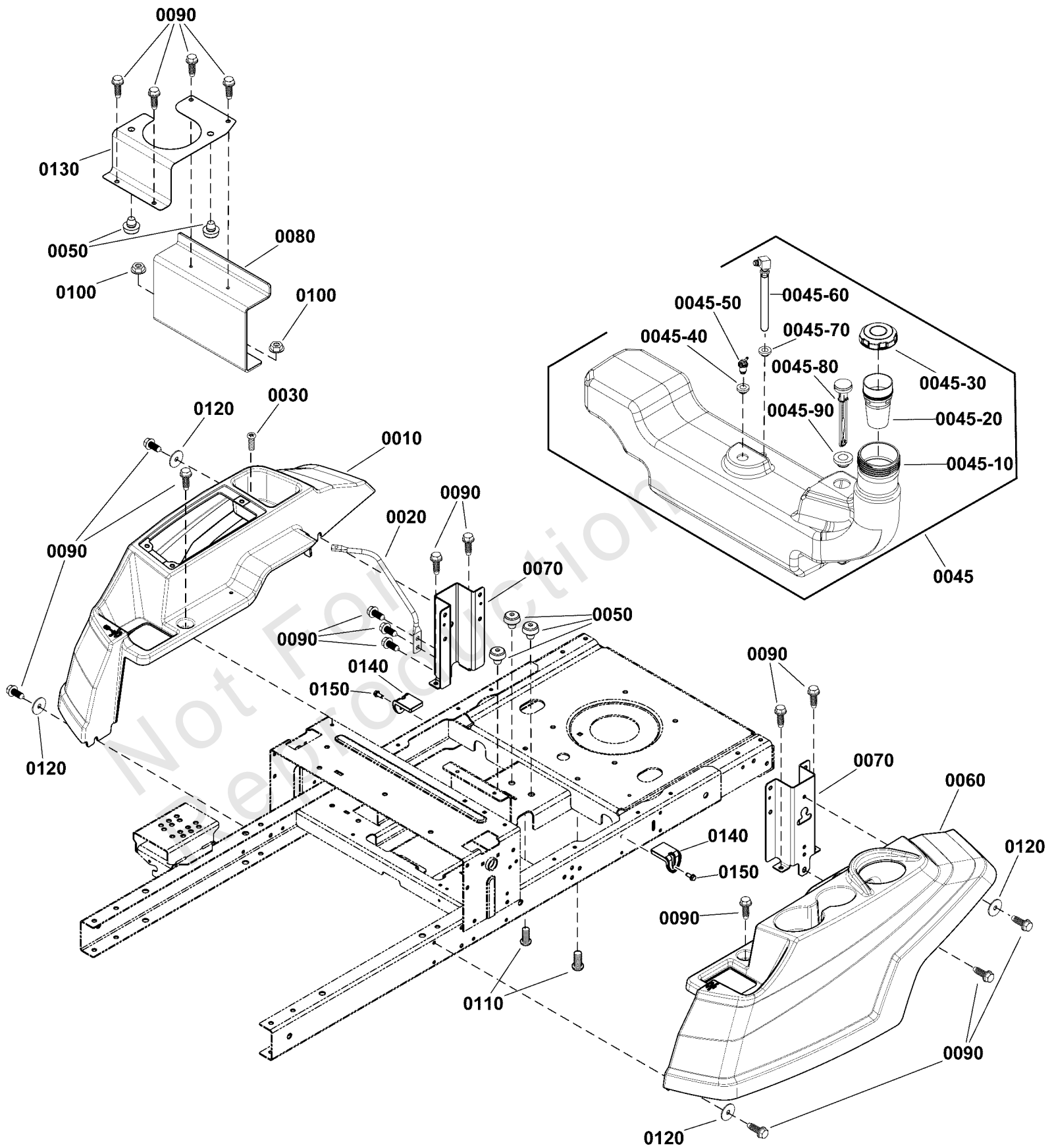



## Body & Fuel Tank Group

REF NO	PART NO	QTY	DESCRIPTION
0010	84008779	1	FENDER, Right
0020	1759369YP	1	ROD, Support
0030	7090999FS	1	SCREW
0045	84004694	1	FUEL TANK ASSEMBLY -(Includes item Nos. 0045-10 thru 0045-90)
0045-10	-----	1	TANK, Fuel -(Order item 0045)
0045-20	-----	1	NECK, Fuel Filter -(Order item 0045)
0045-30	1758314YP	1	CAP-FUEL TANK
0045-40	799624	1	GROMMET
0045-50	770046	1	REMOTE VENT ASSEMBLY
0045-60	1758927YP	1	TUBE-PICK UP
0045-70	1726400FS	1	BUSHING
0045-80	1758928YP	1	GAUGE-FUEL
0045-90	84004692	1	GROMMET
0050	197546GS	5	MOUNT-VIBRATION
0060	1758076YP	1	FENDER-LEFT
0070	84007754	2	SUPPORT, Fender
0080	84002196	1	BRACKET
0090	5022308SM	18	BODY CLIP, 5/16-18 X
0100	5025394SM	2	NUT, 3/8-16 HEX NYLOCK
0110	704038	2	SCREW
0120	1960044SM	4	WASHER-0.312(0.33IDX1
0130	1759140AYP	1	STRAP-FUEL TANK
0140	84002197	2	SUPPORT, FUEL TANK
0150	703054	2	SCREW, 1/4-20X0.625



## Controls Group

REF NO	PART NO	QTY	DESCRIPTION
0010	1758372	2	HANDLE, CONTROL W/ GRIP
0020	5025392	4	NUT, 5/16-18 HEX NYLOCK FLANGE NUT
0030	80004473	4	BOLT,5/16-18X1.000,ROUND HD CRRG,ZC/CL
0040	1757965	2	ARM, UPPER CONTROL
0050	80012294	2	BOLT,SHLDR,5/16-18X.375DIA,GR5,ZINC/CLEA
0060	1757964	2	ARM, LOWER CONTROL
0070	2176440	4	BUSHING-0.765ID 0.885OD 0.877LG NYLON
0080	80005404	10	SCREW,5/16-18X0.625,WSHR,THD-ROLL,ZC/CL
0090	1758087AA	2	BRKT, INNER CONTROL PIVOT
0100	5022308	2	BODY CLIP, 5/16-18-7GA MATERIAL
0110	1758373	2	KNOB, 5/16-18 X 2.50" STUD
0120	1650347	2	SPRING-COMP 0.50 IDX 02.328LG .063WIRE D
0130	5025211	4	PIN, HAIR, .0585 X 1-1/8, 1/4 EYE, YZ
0140	1758463	2	ROD, DAMPNER MNT
0150	5105587	2	DAMPENER, 18MM X 70MM
0160	1759182	2	LATCH, CONTROL ARM
0170	80003579	4	BOLT,1/4-20X.75,GR5,RH SH SQ NK,ZNC/CLR
0180	5025391	4	NUT, 1/4-20 Hex Nylock Flange
0190	80012410	2	WASHER, 3 WAVE, .750" ID
0200	5025057	2	NUT, Hex, Nylon Locking, 5/16-18

**Decal Group - Brand and Model**

Note: Unless noted otherwise, use the standard torque specifications

Mfg. No: 5902052

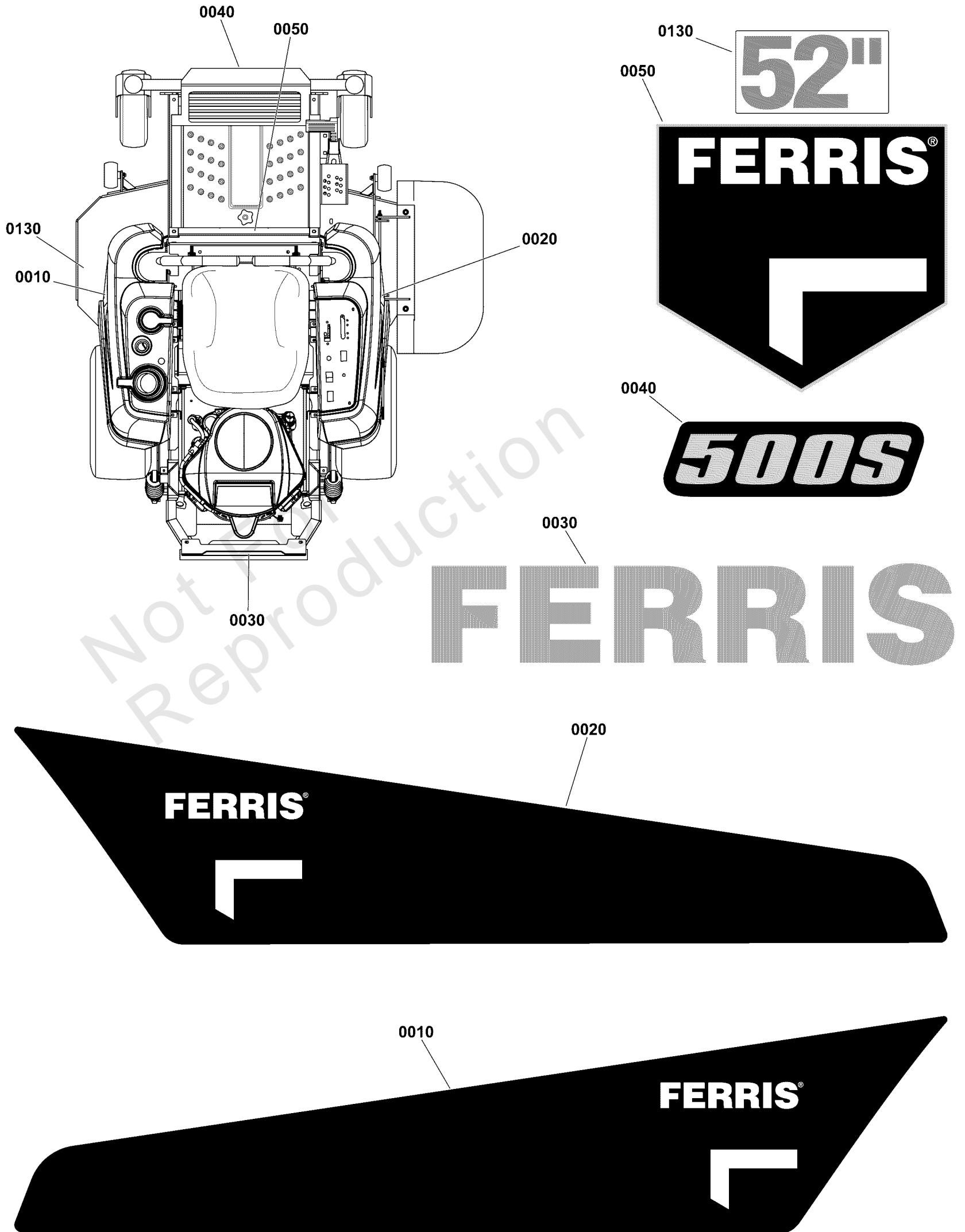

### *Decal Group - Brand and Model*

REF NO	PART NO	QTY	DESCRIPTION
0010	80106105FS	1	DECAL, BRAND
0020	80106106FS	1	DECAL, BRAND
0030	80106081FS	1	DECAL, BRAND
0040	80106107FS	1	DECAL, Model
0050	5104724FS	1	DECAL, BRAND
0130	5022812SM	1	DECAL, 52

Not For Reproduction

# Decal Group - Safety and Operation

Note: Unless noted otherwise, use the standard torque specifications

Mfg. No: 5902052

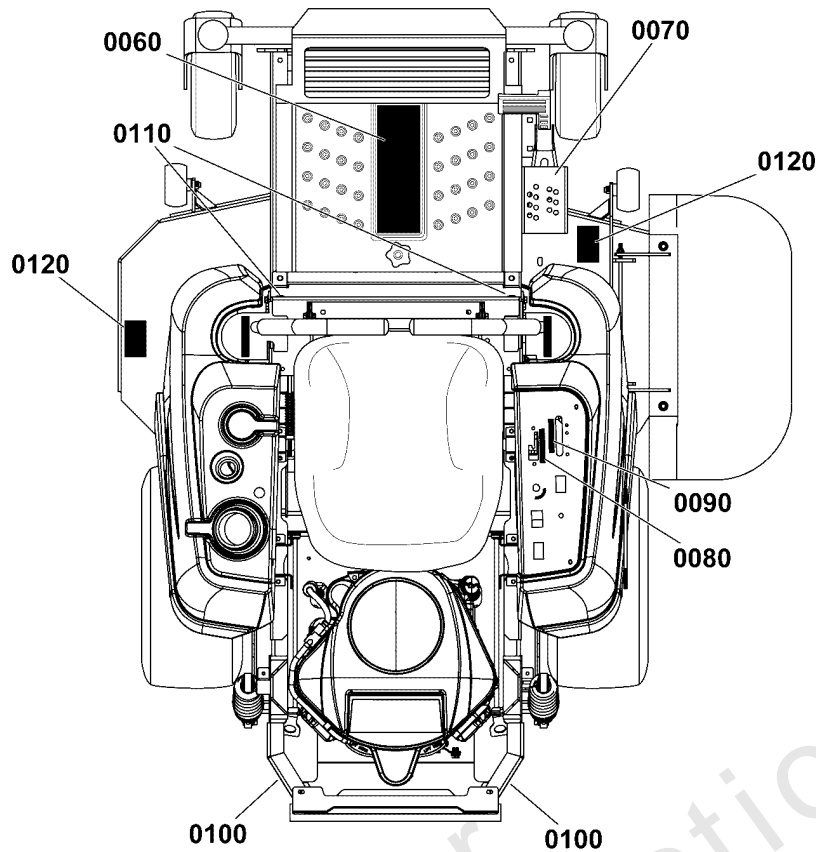

**⚠ DANGER**

**Amputation hazard**  
Rotating blades cut off arms and legs.

- Stop the mower when children or others are near.
- Do not carry riders (especially children) even with the blades off. They may fall off or return for another ride when you are not expecting it.
- Look down, behind and to the side before changing directions.

**Loss of control and roll-over hazard**  
Operating on slopes can be hazardous and cause loss of control and roll-overs.

- Do not operate on slopes over 10 degrees.
- Avoid sudden turns or rapid speed changes.
- Reduce speed and use extreme caution on slopes.
- Avoid turning down slopes; if possible turn up slopes.
- If machine stops forward motion on a slope, stop the blades and drive slowly off the slope.

**Water, retaining walls and drop-off hazards**  
Wheels dropping over edges may result in serious injury, death or drowning.

- Do NOT operate down slope towards or near water, retaining walls or drop-offs.
- Give yourself a minimum of two mower widths of clearance around these hazards.

---

**⚠ WARNING**

**Fire hazard**  
Gasoline is flammable. Yard debris is combustible.

- Allow engine to cool for at least 3 minutes before refueling.
- Keep unit cleaned of debris.
- This equipment may create sparks that can start fires around dry vegetation. A spark arrester may be required. Contact local fire agencies for regulations relating to fire prevention requirements.

**Avoid serious injury or death**  
Read the operator's manual before using this product.

- Do NOT operate this machine unless you are trained.
- Know the location and function of all controls.
- Keep safety devices (guards, shields, switches, etc.) in place and working.
- Remove objects that could be thrown by the blade.
- Be sure blade(s) and engine are stopped before placing hands or feet near blade(s).
- When leaving machine, shut off, remove key, and set parking brake.

CAN ICES-2/NMB-2 510664-A

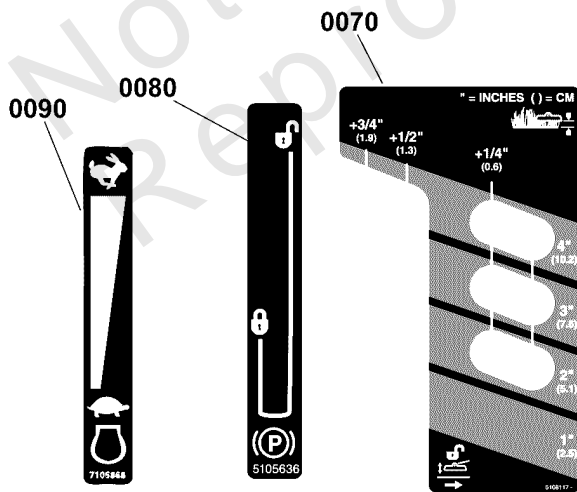

**⚠ DANGER**

**Amputation and thrown objects hazard**

- Keep hands and feet away from deck.
- Do not operate mower unless discharge chute or entire grass catcher is in its proper place.

7101666

**0150**

**HYDRAULIC OIL**

---

**USE SAE 20W-50 MOTOR OIL**

5100957

**0140**

**Belts & Blades**

Tractor	
Pump Drive Belt	80103769
48" Mower	
Deck Drive Belt	80105246
Mower Blade (Set)	1759056S
52" Mower	
Deck Drive Belt	80098314
Mower Blade (Set)	1756152S
61" Mower	
Deck Drive Belt	80093909
Mower Blade (Set)	5104045S

8010600 B

**0160**

The operator's manual is available in Spanish.  
La manual del operador está disponible en Español.

---

**CAN ICES-2/NMB-2**

510286 B

**0100**

1 STOP

2 STOP

---

1 STOP

2 STOP

1759466

## Decal Group - Safety and Operation

REF NO	PART NO	QTY	DESCRIPTION
0060	84007898	1	DECAL, Main Safety
0070	5108117	1	DECAL, CUTTING HEIGHT
0080	5105636	1	DECAL, OPERATION, PARK BRAKE
0090	7105868	1	DECAL, ENGINE SPEED - NO CHOKE
0100	1759466	2	DECAL, TOW VALVE RELEASE (SUSP)
0110	1759724	2	DECAL, TRACKING ADJUSTMENT - ZT
0120	84007896	2	DECAL, Danger, Cut Hand/Foot
0140	80106630	1	DECAL, FERRIS SERVICE, 48"/52"/61" ZT -(Located on the bottom of seat plate.)
0150	5100957	1	DECAL, HYDRAULIC OIL, SAE 20W50 -(Located on the bottom of seat plate.)
0160	5104269	1	DECAL, SPANISH MANUAL, IGES, C-TICK -(Located on left frame rail near front of fuel tank.)

Not For Reproduction

# Electrical Group

Note: Unless noted otherwise, use the standard torque specifications

Mfg. No: 5902052

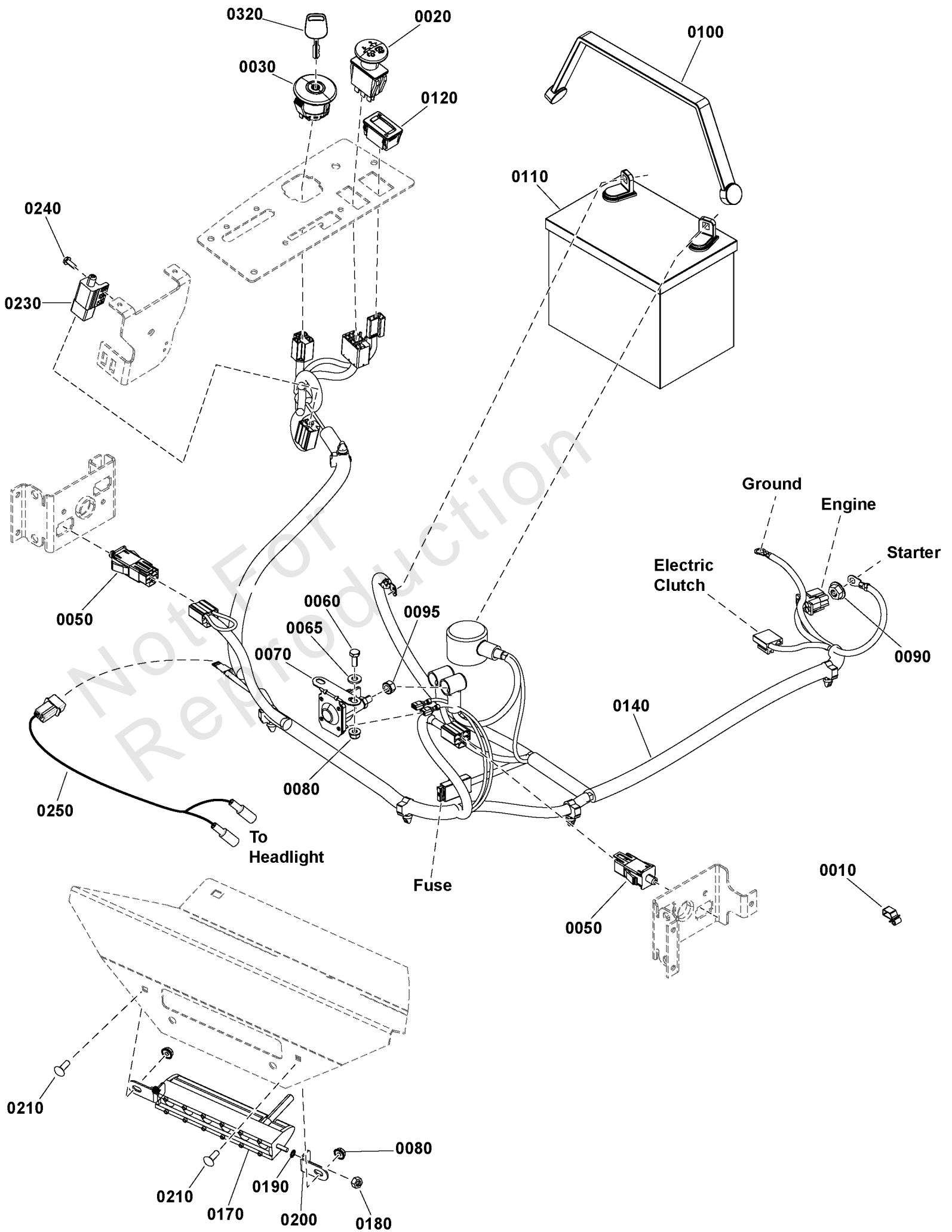



## Electrical Group

REF NO	PART NO	QTY	DESCRIPTION
0010	2172434SM	3	CLIP- WIRE DIA .390
0020	1722887SM	1	SWITCH-PTO PUSH
0030	7106169YP	1	SWITCH, IGNITION, DEL
0050	7022886YP	2	SWITCH, DP NO/NC SNAP
0060	703338	2	BOLT,1/4-20X5/8
0065	84007033	2	WASHER
0070	1755381YP	1	SOLENOID, L-BRACKET
0080	5025391FS	4	NUT
0090	703061	1	NUT, HEX KEPS, 1/4-20
0095	2860750SM	2	NUT-HEX KEPS 5/16-24
0100	1722009SM	1	STRAP, Rubber, 13"
0110	-----	1	BATTERY, 12 VOLT, 230 CCA
0120	1731185SM	1	METER-HOUR DIGITAL NO
0140	84006894	1	HARNESS, WIRING -(Includes item # 0140-10.)
0140-10	5021603SM	1	FUSE, ATO, 20 AMP -(Not illustrated.)
0170	84006903	1	HEADLIGHT ASSEMBLY
0180	84007034	2	NUT, Hex, M5X.8MM, Nylon Insert
0190	84007035	2	WASHER, 5MM, Star
0200	84007036	2	BRACKET, L Headlight Mount
0210	703575	2	BOLT, 1/4-20X.750, SQ
0230	1717050SM	1	SWITCH-PUSH BUTT
0240	704060	2	SCREW,HEX, #10-24X.5
0250	84006895	1	HARNESS, Headlight Jumper
0320	7106170FS	1	BLISTER PACK, KEY NO MOW & FOB

# Electrical Schematic - Charging Circuit - B&S 44C777 & 44T977

Note: Unless noted otherwise, use the standard torque specifications

Mfg. No: 5902052

## 80097605 MAIN WIRE HARNESS - BRIGGS & STRATTON 44C777 & 44T977 ENGINES

80097605A

(If internal schematic of the switch is not shown, the image of the switch represents the back view of the connector as it is connected to the switch.)

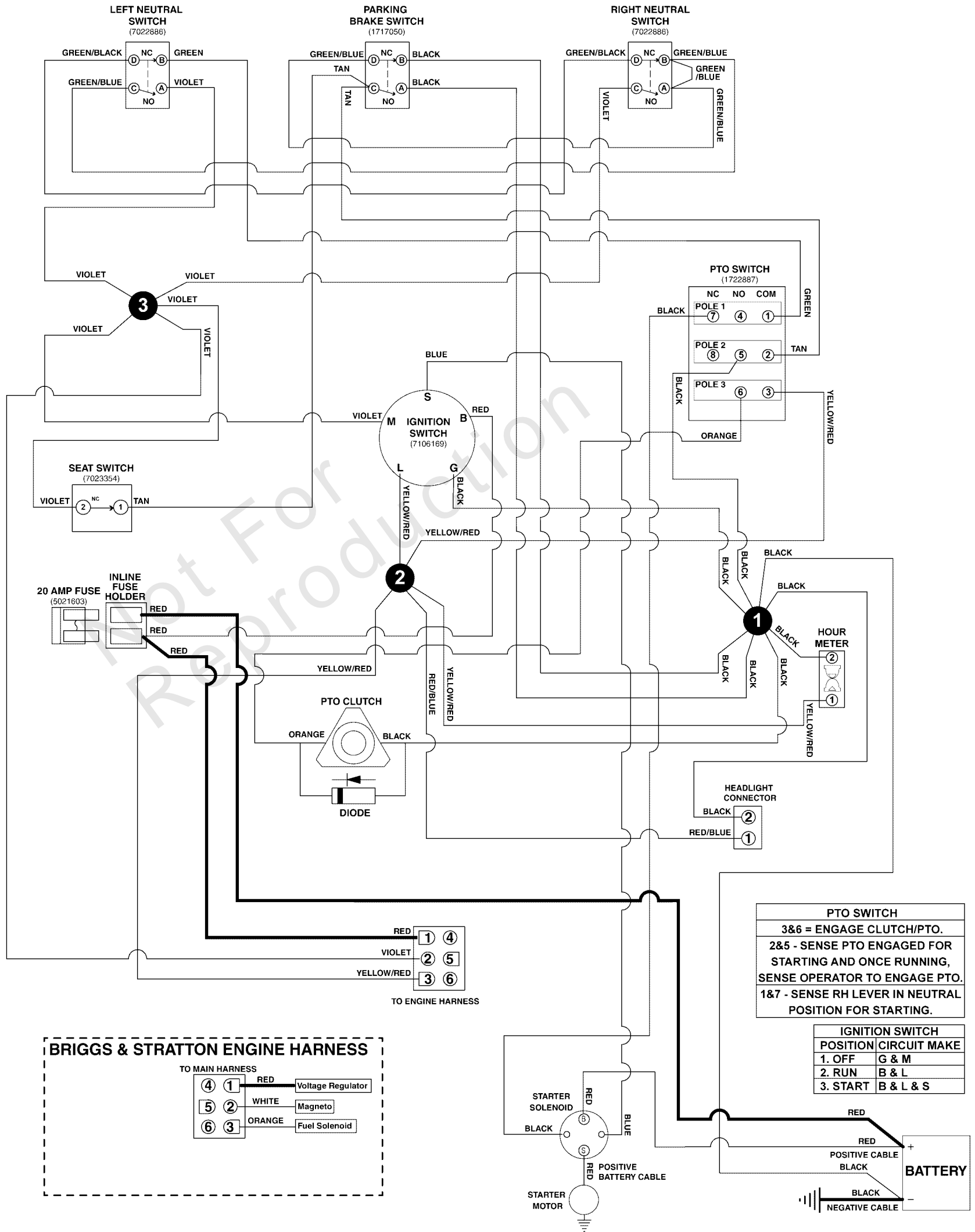

## Electrical Schematic - Charging Circuit - B&S 44C777 & 44T977

REF NO	PART NO	QTY	DESCRIPTION
80097605	84006894	1	HARNESS, WIRING
7022886	7022886YP	2	SWITCH, DP NO/NC SNAP
1717050	1717050SM	1	SWITCH-PUSH BUTT
1722887	1722887SM	1	SWITCH-PTO PUSH
7106169	7106169YP	1	SWITCH, IGNITION, DEL
7023354	7023354YP	1	SWITCH, SEAT
5021603	5021603SM	1	FUSE, ATO, 20 AMP

Not For Reproduction

# Electrical Schematic - Cranking Circuit - B&S 44C777 & 44T977

Note: Unless noted otherwise, use the standard torque specifications

Mfg. No: 5902052

## 80097605 MAIN WIRE HARNESS - BRIGGS & STRATTON 44C777 & 44T977 ENGINES

80097605A

(If internal schematic of the switch is not shown, the image of the switch represents the back view of the connector as it is connected to the switch.)

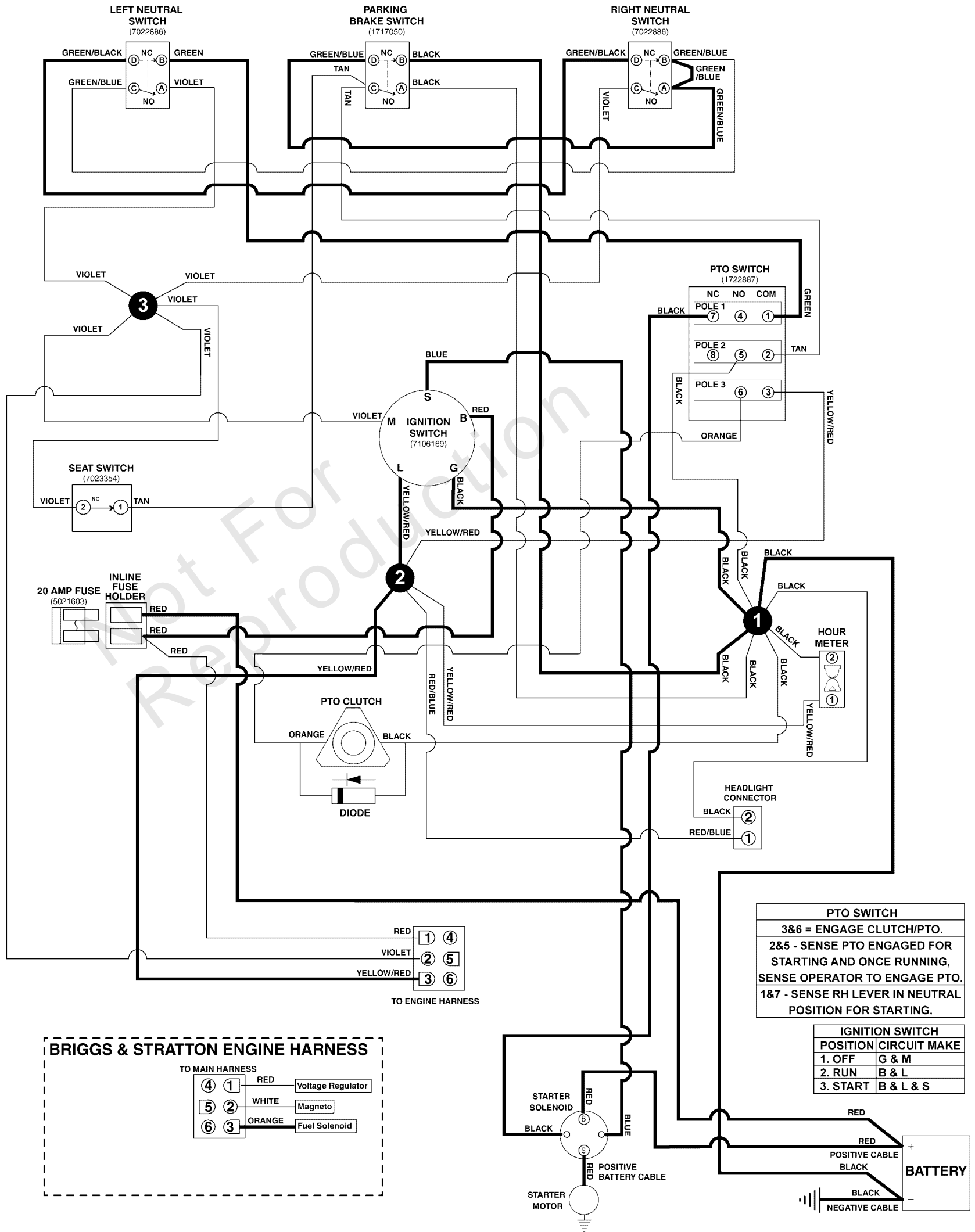

## Electrical Schematic - Cranking Circuit - B&S 44C777 & 44T977

REF NO	PART NO	QTY	DESCRIPTION
80097605	84006894	1	HARNES, WIRING
7022886	7022886YP	2	SWITCH, DP NO/NC SNAP
1717050	1717050SM	1	SWITCH-PUSH BUTT
1722887	1722887SM	1	SWITCH-PTO PUSH
7106169	7106169YP	1	SWITCH, IGNITION, DEL
7023354	7023354YP	1	SWITCH, SEAT
5021603	5021603SM	1	FUSE, ATO, 20 AMP

Not For Reproduction

# Electrical Schematic - Ignition Grounding Circuit/Op. Pres. - B&S 44C777 & 44T977

Note: Unless noted otherwise, use the standard torque specifications

Mfg. No: 5902052

## 80097605 MAIN WIRE HARNESS - BRIGGS & STRATTON 44C777 & 44T977 ENGINES

80097605A

(If internal schematic of the switch is not shown, the image of the switch represents the back view of the connector as it is connected to the switch.)

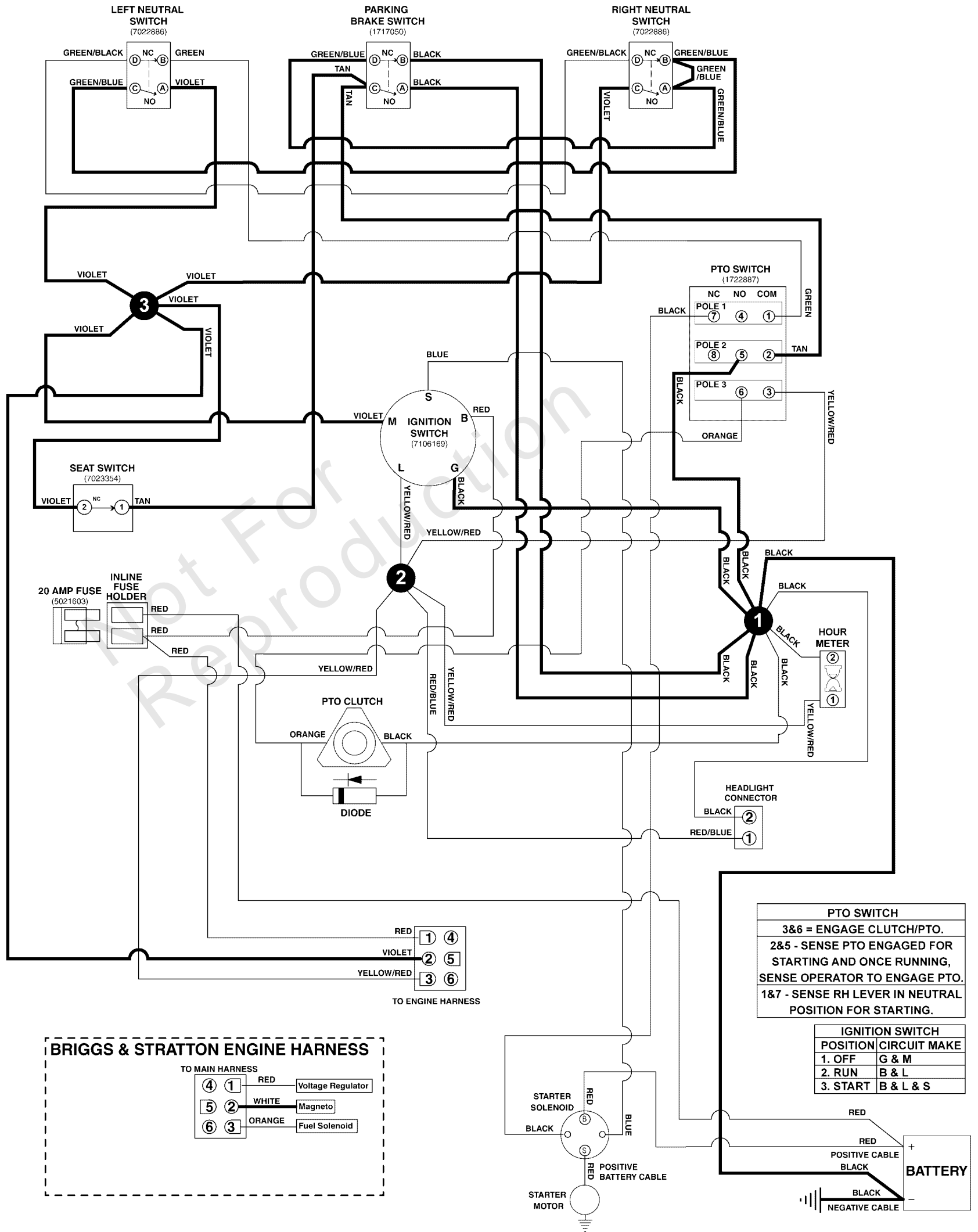

**Electrical Schematic - Ignition Grounding Circuit/Op. Pres. - B&S 44C777 & 44T977**

REF NO	PART NO	QTY	DESCRIPTION
80097605	84006894	1	HARNESS, WIRING
7022886	7022886YP	2	SWITCH, DP NO/NC SNAP
1717050	1717050SM	1	SWITCH-PUSH BUTT
1722887	1722887SM	1	SWITCH-PTO PUSH
7106169	7106169YP	1	SWITCH, IGNITION, DEL
7023354	7023354YP	1	SWITCH, SEAT
5021603	5021603SM	1	FUSE, ATO, 20 AMP

Not For Reproduction

# Electrical Schematic - PTO Clutch Circuit - B&S 44C777 & 44T977

Note: Unless noted otherwise, use the standard torque specifications

Mfg. No: 5902052

## 80097605 MAIN WIRE HARNESS - BRIGGS & STRATTON 44C777 & 44T977 ENGINES

80097605A

(If internal schematic of the switch is not shown, the image of the switch represents the back view of the connector as it is connected to the switch.)

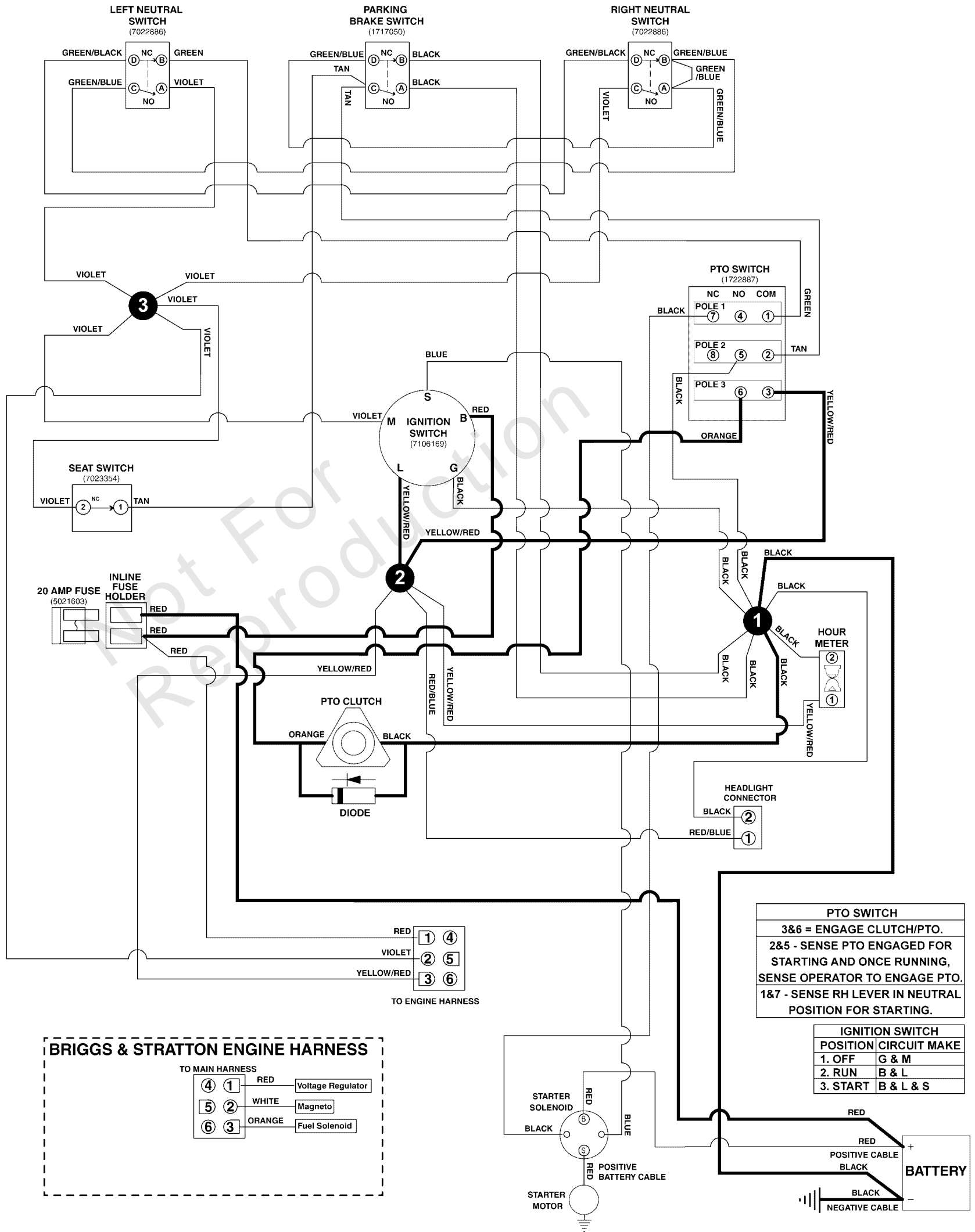



## **Electrical Schematic - PTO Clutch Circuit - B&S 44C777 & 44T977**

<b>REF NO</b>	<b>PART NO</b>	<b>QTY</b>	<b>DESCRIPTION</b>
80097605	84006894	1	HARNESS, WIRING
7022886	7022886YP	2	SWITCH, DP NO/NC SNAP
1717050	1717050SM	1	SWITCH-PUSH BUTT
1722887	1722887SM	1	SWITCH-PTO PUSH
7106169	7106169YP	1	SWITCH, IGNITION, DEL
7023354	7023354YP	1	SWITCH, SEAT
5021603	5021603SM	1	FUSE, ATO, 20 AMP

Not For Reproduction

# Engine and PTO Group

Note: Unless noted otherwise, use the standard torque specifications

Mfg. No: 5902052

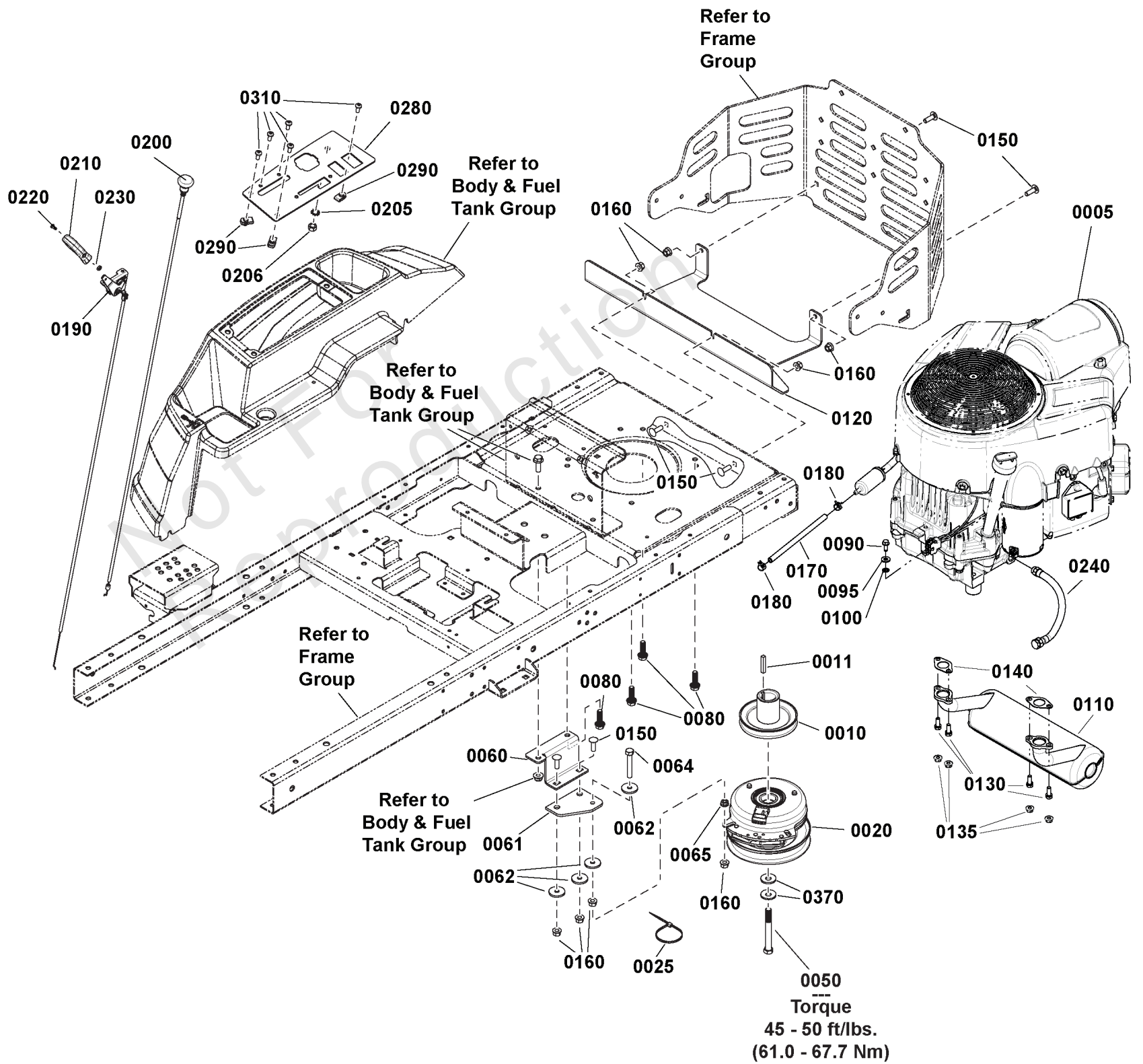

## Engine and PTO Group

REF NO	PART NO	QTY	DESCRIPTION
0005	44T977-0005-G1	1	* ENGINE, 25HP B&S COMM TURF, 1-1/8 X 4.29 -( Engine Model: 44T777-0005-G1 )
0010	80098036	1	PULLEY, CRANKSHAFT
0011	5022726	1	KEY 1/4 SQ X 1 1/2 LONG
0020	80093964	1	CLUTCH, WARNER, 125 FT-LB, 1.13" X 6.324
0025	5021030	1	TIE, SELF-LOCKING, 6"
0050	5102868	1	BOLT, CRANKSHAFT, 7/16-20 X 3-3/4, GD8
0060	80093428AA	1	BRKT, CLUTCH ANCHOR (BLACK)
0061	80093429	1	PAD, CLUTCH ANCHOR
0062	5044617	4	WASHER, .34 X 1.25 X 10 GA
0064	5025055X18	1	BOLT, 5/16-18 X 2-1/4 TFL, GD5 YZ
0065	5025127	1	NUT, 5/16-18 HEX SERRATED FLANGE (SMALL)
0080	80020381	4	SCREW-HEX WSHR HD TAPTT 3/8-16X1.250, ZC
0090	80004190	1	SCREW, Hex Washer Head, Thread Roll, 1/4-20 x 5/8
0095	5025154	1	WASHER, 1/4 SAE
0100	1921880	1	LOCKWASHER, External Tooth, 1/4
0110	84008807	1	MUFFLER ASSEMBLY
0120	80096582AA	1	SHIELD, HEAT (BLACK)
0130	94480	4	SCREW
0135	810086	4	NUT
0140	273485	2	GASKET, EXHAUST
0150	80004565	6	BOLT, 5/16-18X1.000, SHORT NECK CRRG, ZC/CL
0160	5025392	8	NUT, 5/16-18 HEX NYLOCK FLANGE NUT
0170	5050831X11	1	1/4" Fuel Line, 11" Long
0180	93807	2	CLAMP, Hose
0190	1759205	1	CONTROL, THROTTLE-THROTTLE ONLY (40.0LG)
0200	5100184	1	CABLE, CHOKE CONTROL, 43.5"
0205	80005209	1	WSHR, 3/8EXT TOOTH LOCK, TYPE A, ZINC/CLR
0206	80004865	1	NUT, 3/8-24, HEX, GR 5, ZINC/CLEAR
0210	1739312	1	KNOB, Throttle
0220	36917	1	SCREW, Pan Head Machine - No. 8-32 x 3/8"
0230	80004411	1	NUT #8-32 HEX ZINC/CLEAR
0240	1726498	1	HOSE-OIL DRAIN .375ID 16.5L
0280	80095386AA	1	PANEL, CONTROL (BLACK)
0290	5022665	3	BODY CLIP, 1/4-20 X 1/2" DEEP
0310	7090999	5	SCREW, 1/4-20 x 5/8" Pan Head Self-Tap (Torx)
0370	5025585	2	BELLEVILLE WASHER, 1.1875 X .442 X .098

### Footnotes:

Note:\* See your local Briggs & Stratton distributor for parts & service.

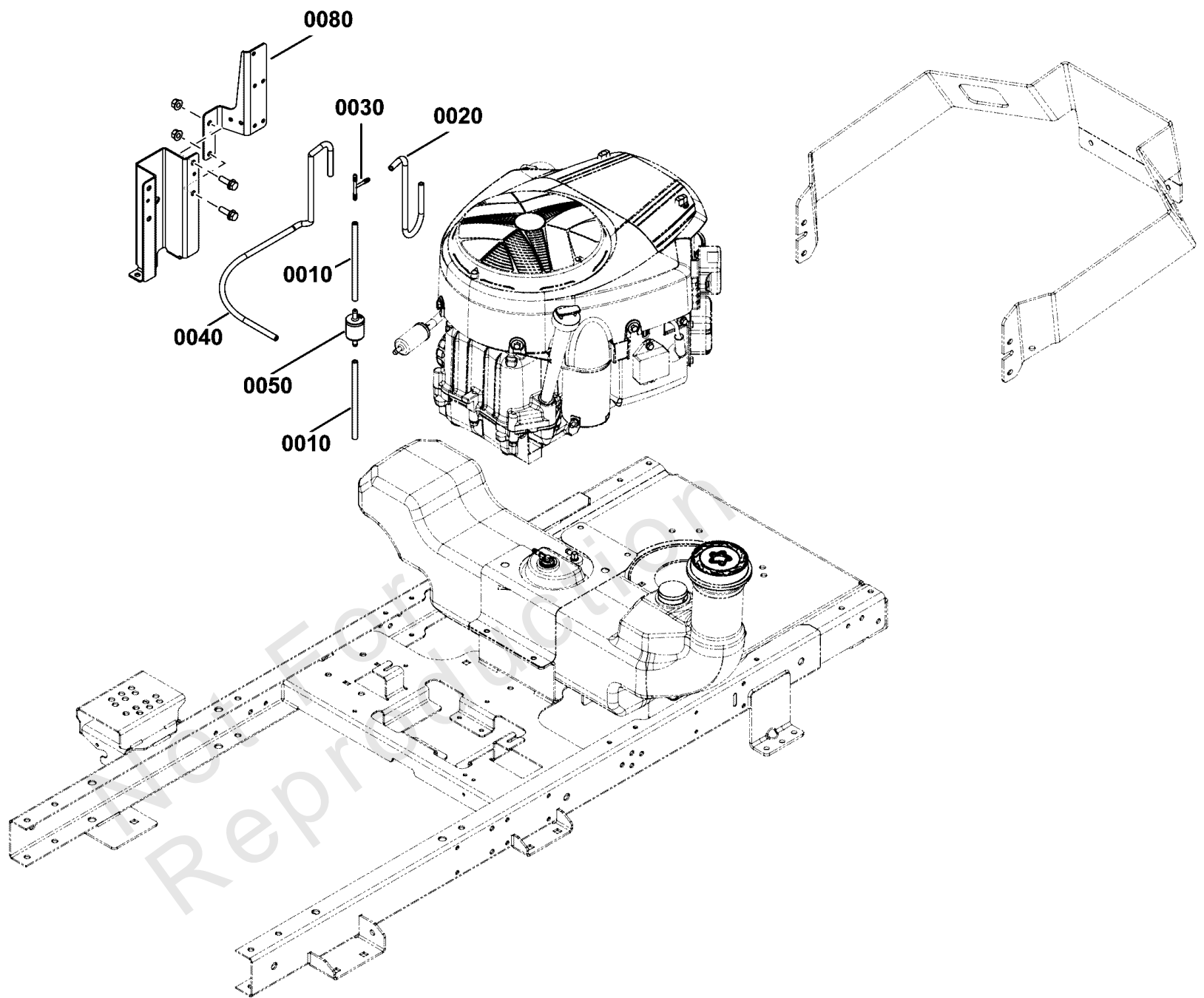

## EVAP Group

REF NO	PART NO	QTY	DESCRIPTION
0010	7700552X6	2	HOSE, Vapor, 5 MM ID, 6.00 LG
0020	7700552X12	1	HOSE, VAPOR, 5MM ID, 12.00 LG
0030	5103062	1	FITTING, 3/16" TEE, BARB TYPE, HDPE
0040	7700552X26	1	HOSE, VAPOR, 5MM ID, 26.00 LG
0050	80025019	1	FILTER, FUEL
0070	5021030	5	TIE, SELF-LOCKING, 6" -(Not Illustrated)
0080	1760538A	1	BRACKET, Vent Hose Mount - BS Twin (BLK)

Not For Reproduction

# Frame, Pivoting Front Axle, Floor Pan, and Bumper Group

Note: Unless noted otherwise, use the standard torque specifications

Mfg. No: 5902052

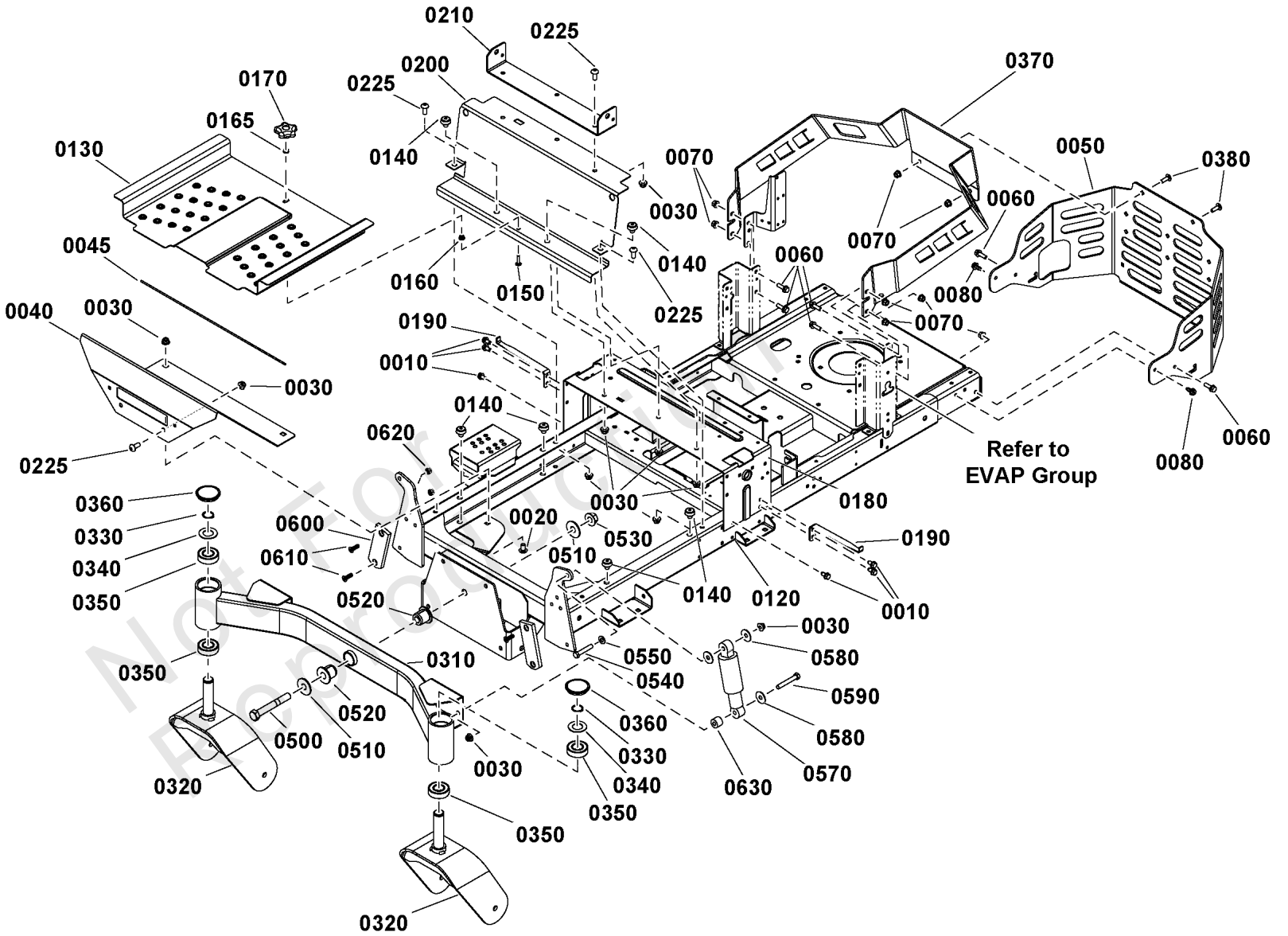

## Frame, Pivoting Front Axle, Floor Pan, and Bumper Group

REF NO	PART NO	QTY	DESCRIPTION
0010	703949	6	SCREW, 5/16-18.625
0020	703448	2	BOLT, 3/8-16X.75 G5
0030	5025394SM	13	NUT, 3/8-16 HEX NYLOCK
0040	80096035BFS	1	FOOTREST, FRONT
0045	5101011SM	1	SAFETY WALK, 8.00 X 1
0050	80104055BFS	1	BUMPER, REAR
0060	703410	6	BOLT,5/16-18X1
0070	703115	8	NUT
0080	703228	2	SCREW, 5/16-18 X .75
0120	-----	1	WELDMENT, ZT XT FRAME-FULL SUSP(FER R) -( Not a serviceable part )
0130	84009431	1	FOOT PAN W/DECAL, 2019 (1757813B) -(USA Models)
0130	5601199	1	FOOT PAN W/DECAL, EXPORT 2019 (1757813B) -(AUS Models)
0140	197546GS	6	MOUNT-VIBRATION
0150	7090496YP	1	RHSSNB, 1/4C X1 GR5 Z
0160	5025126FS	1	NUT
0165	15X143MA	1	NUT,25-20 HEX FLG CTR
0170	707785	1	KNOB
0180	80096436BFS	1	BRACKET, CONTROL
0190	1758240AFS	2	SUPPORT, FENDER
0200	1757796BYP	1	PLATE-DECAL
0210	5416789BFS	1	PIVOT
0225	84004627	7	CAPSCREW
0310	80096786BFS	1	PIVOT
0320	84007952	2	YOKE, Caster
0330	703993	2	RETAINER, EXT RING, 1
0340	703199	2	WASHER, 1
0350	1758354YP	4	BEARING
0360	5109884FS	2	CAP
0370	80096896BFS	1	BRACKET
0380	703800	2	BOLT, CRRG, 5/16-18X1
0500	707789	1	BOLT
0510	1960035SM	2	WASHER-0.625(0.64IDX1
0520	1759234YP	2	BUSHING
0530	84003031	1	NUT
0540	703589	2	CAPSCREW, 3/8-16X2
0550	5025156FS	2	WASHER
0570	1755279YP	2	SHOCK ABSORBER, 8IN
0580	5025165SM	6	WASHER, 3/8" FENDER
0590	84007037	2	BOLT
0600	1759391YP	2	PAD-FRICTION
0610	5025594YP	4	SCREW, 5/16-18 X 1
0620	5025057FS	4	NUT
0630	1667812SM	2	SPACER

# Lift Group

Note: Unless noted otherwise, use the standard torque specifications

Mfg. No: 5902052

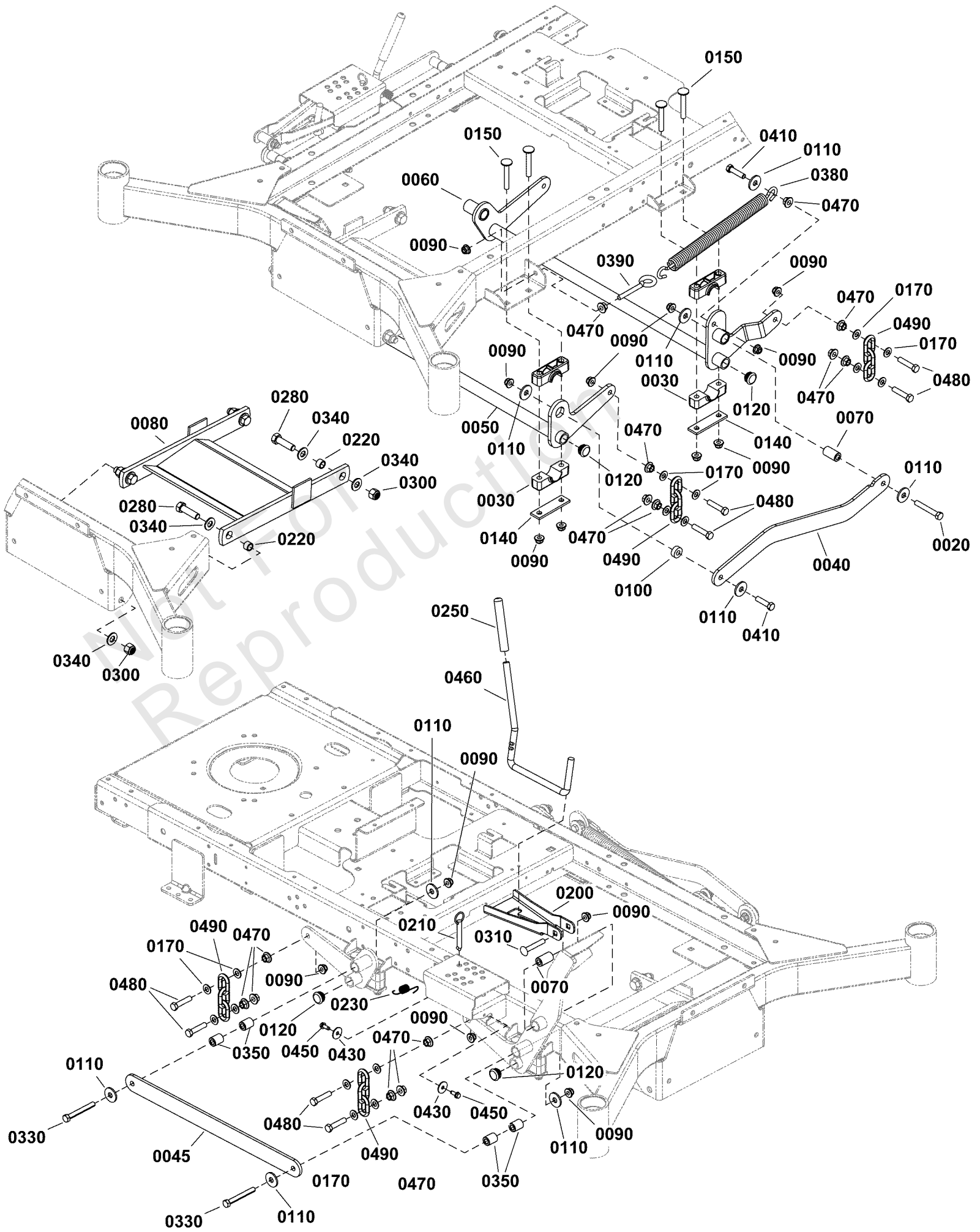



## Lift Group

REF NO	PART NO	QTY	DESCRIPTION
0020	84007037	1	BOLT
0030	5100634SM	8	PIVOT BLOCK, PLASTIC
0040	84006925	1	LINKAGE
0045	84006926	1	LINKAGE, Lift Assist, RH
0050	84006914	1	LIFTER
0060	84006915	1	SHAFT ASSEMBLY
0070	1756612YP	2	BUSHING, DIFF. LOCK
0080	84006928	1	BAR, PULLER
0090	5025394SM	19	NUT, 3/8-16 HEX NYLOCK
0100	1667811SM	1	SPACER
0110	1919384SM	9	WASHER-0.375(0.44IDX1
0120	84007871	4	PLUG
0140	5403925AAFS	4	PIVOT
0150	1960615SM	8	BOLT-RD HD SQ NK 3/8
0170	5025156FS	16	WASHER
0200	1758284AYP	1	BRACKET
0210	5103021YP	1	HITCH PIN, 3/8 X 2-1/
0220	5020870SM	4	INSERT, BEARING
0230	1758283YP	1	SPRING, EXTENSION
0250	5021880SM	1	GRIP, FOAM
0280	5025018X14FS	4	BOLT
0300	5025098SM	4	NUT, 1/2-20 HEX NYLON
0310	7900009SM	1	RHSSNB, 3/8-16 X 2-1/
0330	5025013X24SM	2	BOLT, 3/8-16 X 3" GD5
0340	5025158SM	8	WASHER, 1/2" SAE
0350	1733068SM	4	SPACER-0.390IDX0.750O
0380	5023355SM	1	SPRING, DECK LIFT ASS
0390	5025429SM	1	EYEBOLT - 3/8-16
0410	703406	2	CAPSCREW,3/8-16X1.5
0430	5025288YP	2	WASHER, 1/4 FENDER
0450	703054	2	SCREW, 1/4-20X0.625
0460	5105717YP	1	ROD
0470	5025128SM	14	NUT, 3/8-16 HEX SERRA
0480	5025013X14SM	8	BOLT, 3/8-16 X 1-3/4"
0490	5050878X3SM	4	CHAIN, 5/16" GD30, 3

# Parking Brake Group

Note: Unless noted otherwise, use the standard torque specifications

Mfg. No: 5902052

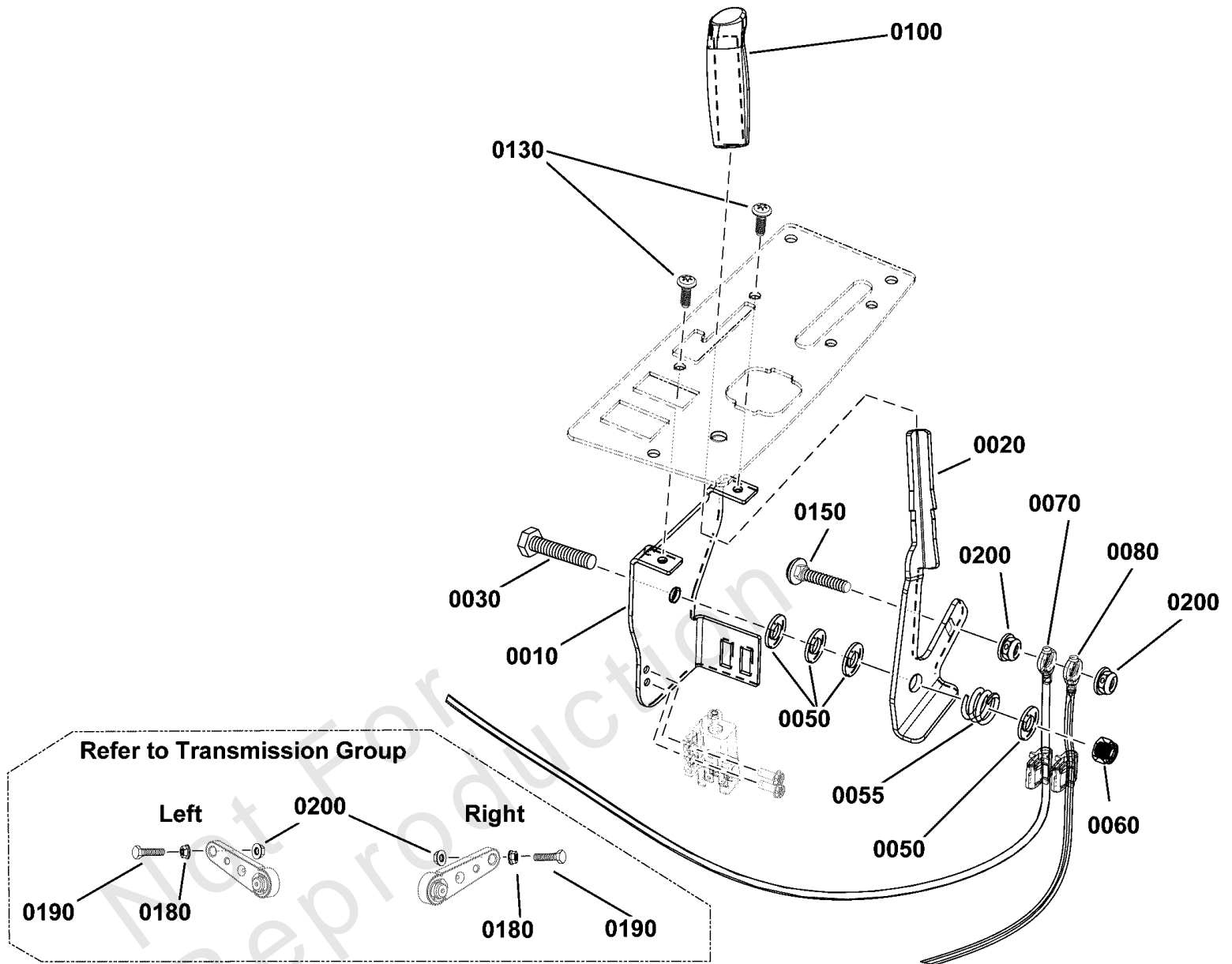

## Parking Brake Group

REF NO	PART NO	QTY	DESCRIPTION
0010	84006916	1	BRACKET
0020	84006917	1	LEVER
0030	703589	1	CAPSCREW, 3/8-16X2
0050	703878	4	WASHER, FLAT
0055	7028036YP	1	SPRING
0060	5025096SM	1	NUT, 3/8-16 HEX NYLON
0070	84006918	1	CABLE, BRAKE
0080	84006919	1	CABLE, BRAKE
0100	84001706	1	GRIP
0130	7090999FS	2	SCREW
0140	703586	3	TIE, SELF LOCKING -(Not Illustrated)
0150	703175	1	BOLT, RD SH SQ
0180	5025127SM	2	NUT, 5/16-18 HEX SERR
0190	5025055X12SM	2	BOLT, 5/16-18 X 1-1/2
0200	703115	4	NUT

Not For Reproduction

# Rear Suspension Group

Note: Unless noted otherwise, use the standard torque specifications

Mfg. No: 5902052

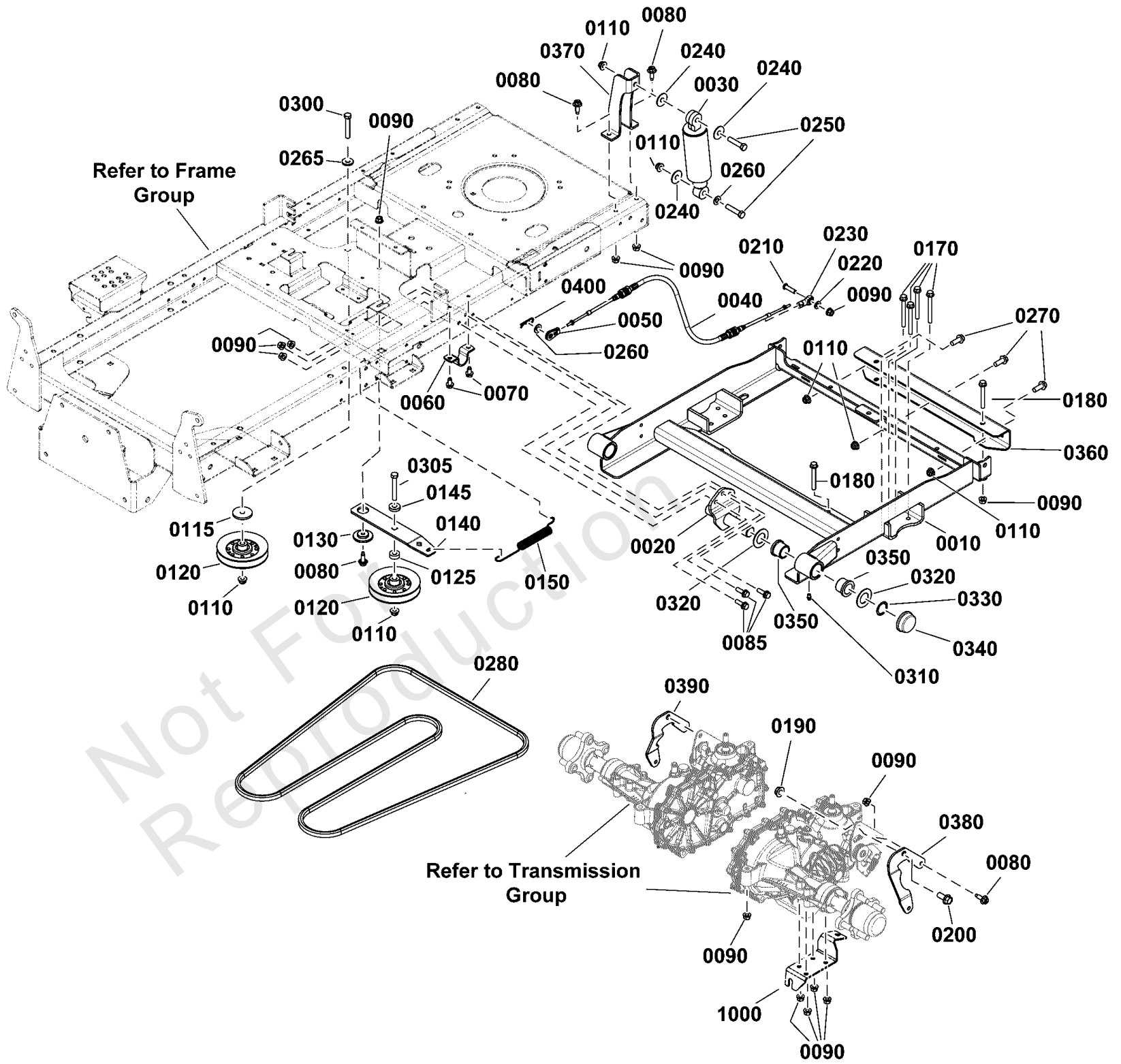

## Rear Suspension Group

REF NO	PART NO	QTY	DESCRIPTION
0010	80092995BFS	1	CARRIER
0020	1758716BYP	2	ARM-LINK
0030	1758705YP	2	SHOCK ABSORBER, 10.5" -(Refer to Note:*)
0040	1759206YP	2	CABLE, Push/Pull
0050	1759413YP	2	END-CABLE
0060	1720147BZYP	2	STRAP, 1 IN. DIA
0070	703949	4	SCREW, 5/16-18.625
0080	1960667SM	7	SCREW-HEX WZ LOCK FLN
0085	703410	6	BOLT,5/16-18X1
0090	703115	27	NUT
0110	5025394SM	9	NUT, 3/8-16 HEX NYLOCK
0115	706128	1	SPACER, IDLER
0120	1759212YP	2	PULLEY
0125	1667811SM	1	SPACER
0130	1727935SM	1	SPACER-PIVOT 0.330ID
0140	1761878AYP	1	ARM, IDLER
0145	5044960SM	1	SPACER, .39 X 1.00 X
0150	1758045YP	1	SPRING-EXTENSION
0170	707943	8	SCREW
0180	770083	4	SCREW
0190	1930650SM	2	NUT-HEX FLANGE 7/16-1
0200	1960043SM	2	SCREW-HEX WZ LOCK FLN
0210	703172	2	SCREW
0220	703350	4	WASHER
0230	5101801YP	2	JOINT-BALL
0240	5025165SM	6	WASHER, 3/8" FENDER
0250	5025013X14SM	4	BOLT, 3/8-16 X 1-3/4"
0260	5025156FS	4	WASHER
0265	704128	1	WASHER
0270	704038	3	SCREW
0280	84006991	1	V-BELT
0300	5025013X18SM	1	BOLT, 3/8-16 X 2-1/4"
0305	84007037	1	BOLT
0310	703907	2	ZERK, FITTING, 1/4
0320	703199	4	WASHER, 1
0330	703200	2	PUSHNUT
0340	094618MA	2	HUB CAP
0350	1758717YP	4	BUSHING
0360	1759163BYP	1	SUPPORT-TRANSAXLE
0370	1758778BYP	2	MOUNT
0380	1759021AYP	1	ARM
0390	1759022AYP	1	ARM
0400	7091503SM	2	HAIR PIN, 3/32X1-1/2
1000	----	1	Refer to: Transmission Group - Suspension

### Footnotes:

Note:\* Spring Rate 160lbs / 59.7kg +/- 10lbs / 3.7kg



## Seat Group - S/N: 4002363335 and Below

REF NO	PART NO	QTY	DESCRIPTION
0020	1752802YP	2	BOLT, SHLDR, 5/16-18
0030	84001620	1	SLIDE, SEAT
0040	703483	2	BOLT,5/16-18X1.000,RO
0060	1717051SM	2	SPRING, Seat
0070	84006921	1	SEAT
0070-10	84006998	1	COVER, Cushion, Snapper -(Not illustrated)
0070-20	84007000	1	COVER, Back, Snapper -(Not illustrated)
0080	703115	12	NUT
0090	704128	2	WASHER
0210	80014989	2	CABLE TIE, 8, PUSH-MOUNT (.250 HOLE)
0220	5103767YP	2	SPACER, .33X.625X.360
0230	5025011X8FS	2	BOLT
0240	703878	2	WASHER, FLAT
0250	703350	2	WASHER
0260	703185	2	BOLT, Round Head, Short Square Neck

# Seat Group - S/N: 4002363336 and Above

Note: Unless noted otherwise, use the standard torque specifications

Mfg. No: 5902052

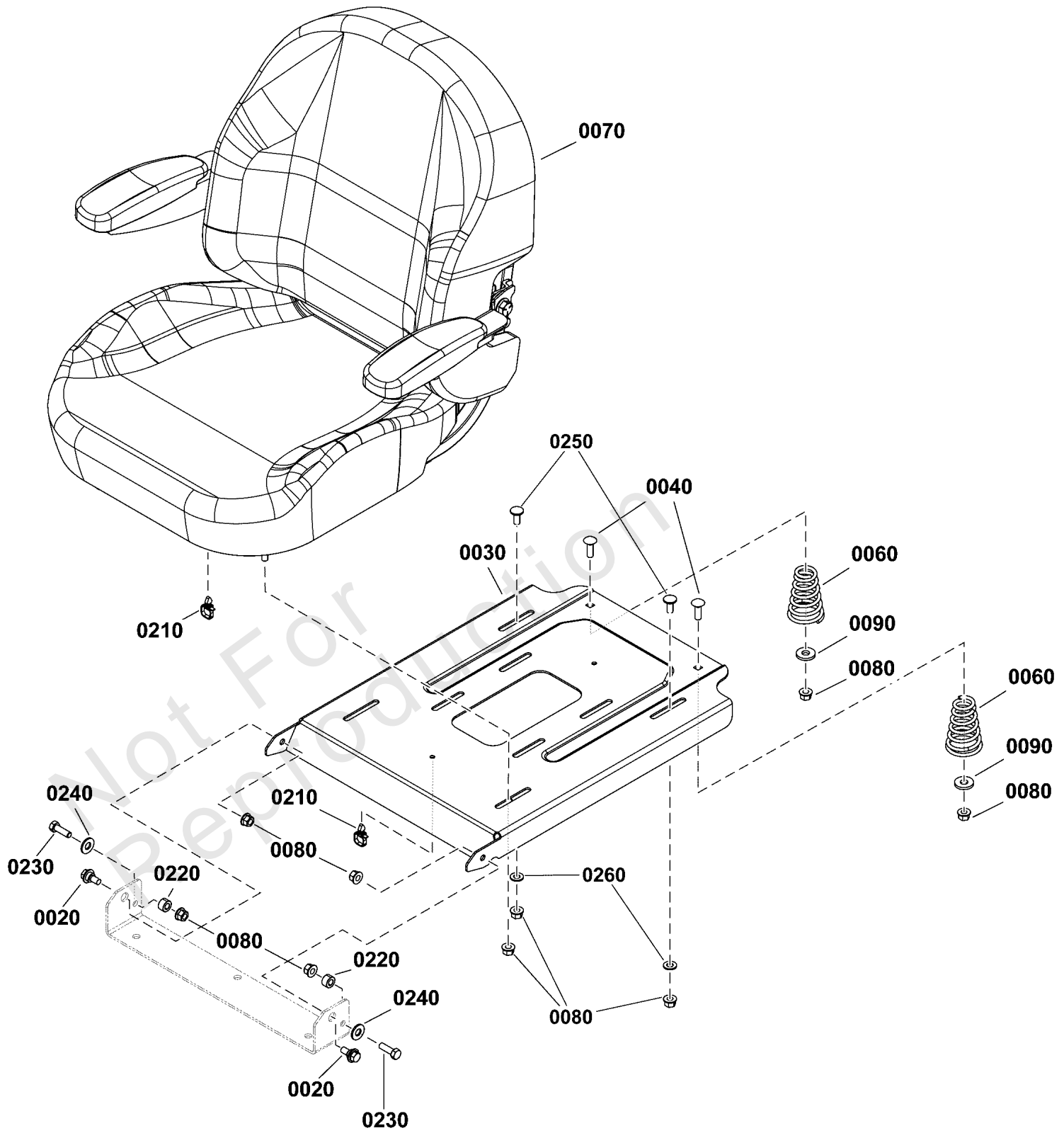



## Seat Group - S/N: 4002363336 and Above

REF NO	PART NO	QTY	DESCRIPTION
0020	1752802YP	2	BOLT, SHLDR, 5/16-18
0030	84001620	1	SLIDE, SEAT
0040	703483	2	BOLT,5/16-18X1.000,RO
0060	1717051SM	2	SPRING, Seat
0070	84010950	1	SEAT ASSEMBLY w/Arm Rests
0070-10	84011194	1	CUSHION, Seat -(Not illustrated)
0070-20	84011193	1	COVER, Seat Back -(Not illustrated)
0070-30	84011192	1	KIT, Armrest -(Not illustrated)
0070-40	84011191	1	TRACKS, Seat Adjustment -(Not illustrated)
0070-50	7023354YP	1	SWITCH, SEAT -(Not illustrated)(Bolt-in)
0070-60	5100541YP	1	SWITCH, NC, W/ TWIST-IN BASE -(Not illustrated)(Twist in)
0080	703115	12	NUT
0090	704128	2	WASHER
0210	80014989	2	CABLE TIE, 8, PUSH-MOUNT (.250 HOLE)
0220	5103767YP	2	SPACER, .33X.625X.360
0230	5025011X8FS	2	BOLT
0240	703878	2	WASHER, FLAT
0250	703350	2	WASHER
0260	703185	2	BOLT, Round Head, Short Square Neck

# Transaxle Service Parts - 84008004 & 84007997

Note: Unless noted otherwise, use the standard torque specifications

Mfg. No: 5902052

## Service Parts Schematic for Hydro-Gear® Transaxles: ZL-HPHH-UL7B-2XLX (84008004) ZL-LPHH-UL7C-3XLX (84007997)

For components not listed see your authorized  
Hydro-Gear® service provider.

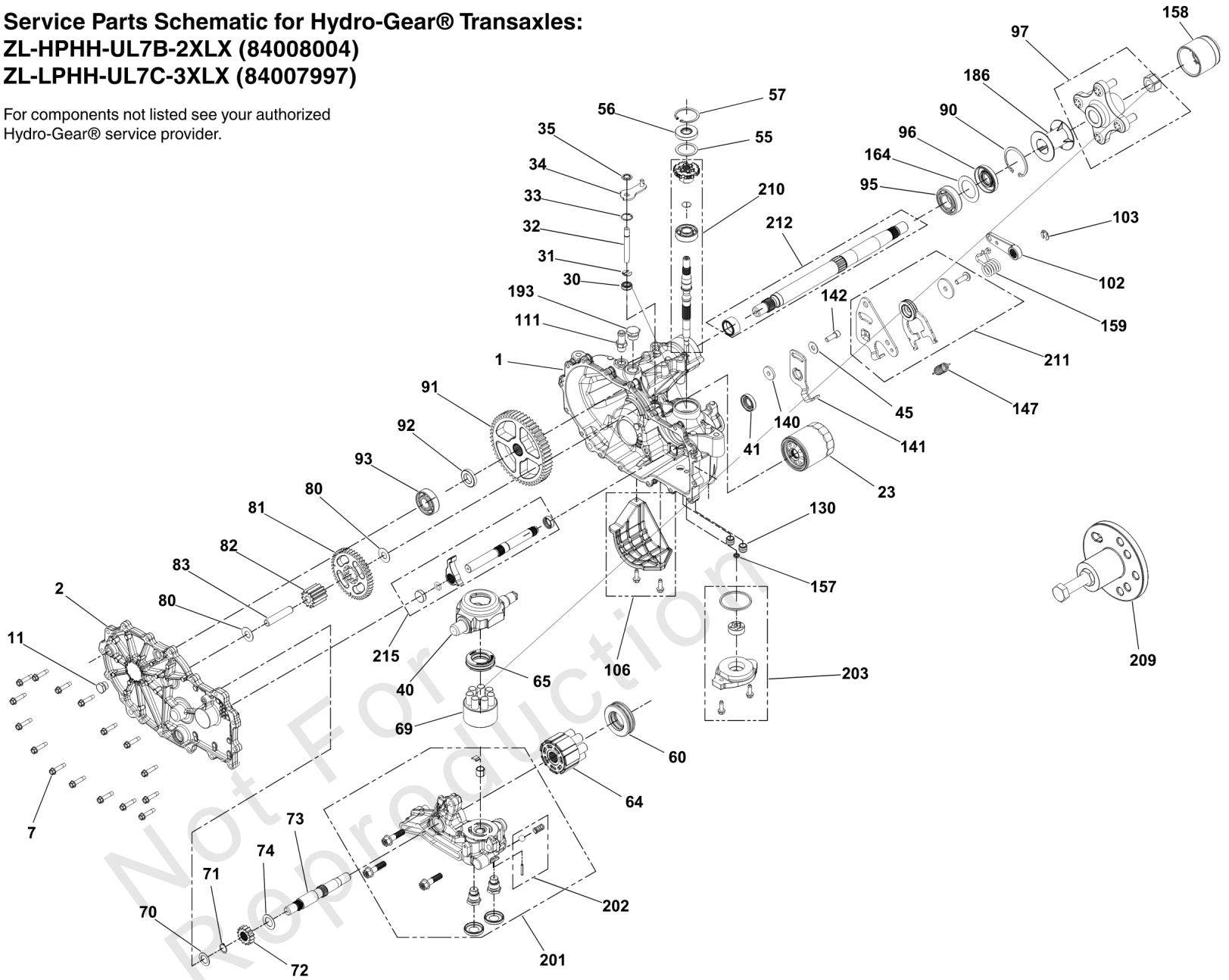

## Transaxle Service Parts - 84008004 & 84007997

REF NO	PART NO	QTY	DESCRIPTION
1	----	1	KIT, HOUSING, MAIN, LH, CHRG, CNTL
2	----	1	KIT, SIDE COVER, LH
7	----	16	SCREW, HEX WASHER
11	----	1	PLUG EXTERNAL HEX VENT 9/16-18
13	----	1	TUBE, SEALANT
23	5101026X1	1	FILTER, OIL, ZT2800
30	84003137	1	SEAL, Lip
31	----	1	BYPASS RETAINING RING 1
32	----	1	ROD, BYPASS .375 X 2.88
33	----	1	BYPASS RETAINING RING 2
34	----	1	ARM, BYPASS
35	----	1	RING, RETAINING .375 EXTERNAL
40	----	1	SWASHPLATE, TRUNNION
41	5101026X2SM	1	SEAL, LIP
45	----	1	WASHER, .34X.88X.06
55	1730272SM	1	SPACER
56	----	1	SEAL, LIP 17 40 7 HNBR
57	5101026X4SM	1	RING, RET 2.06 INT,
60	----	1	BEARING, THRUST 35 x 62 x 18
64	----	1	KIT, 16cc CYLINDER BLOCK ASSEMBLY STEAM TREAT
65	----	1	BEARING, THRUST 30 x 52 x 13
69	----	1	KIT, BLOCK 7 PISTON
70	----	1	WASHER, .63 X 1.00 X .05 FLAT
71	1706130	1	RING-SNAP (44145)
72	----	1	GEAR, 14T (STEEL)
73	----	1	SHAFT, MOTOR
74	----	1	WASHER, .71 X 1.16 X .04 FLAT
80	----	2	WASHER, .51 X 1.00 X .03 FLAT
81	----	1	GEAR, 45T
82	----	1	GEAR, 11T (STEEL)
83	----	1	PIN, JACKSHAFT
90	5101026X17	1	RING, RETAINING 2.25 INTERNAL (50859)
91	----	1	GEAR, 54T
92	----	1	SPACER, .750 X 1.320 X .257
93	5104822X1	1	KIT, BEARING, ZT-3400, 72749
95	5101026X5SM	1	BEARING, BALL, 1.0 X 52 X 15 OPEN 6205M
96	5103589X1	1	KIT, SEAL, AXLE - HG# 53699
97	5103382	1	HUB, ASM, TRANS 5101188/89 & 5102154/55
102	5103750YP	1	BRAKE ARM, ZT-3400
103	5104055YP	1	E-CLIP
106	----	1	KIT, FILTER GUARD
111	----	1	KIT, FITTING 1/2 BEADED 9/16 SAE
130	----	2	TUBE, CHARGE TRIPLE O-RING
140	----	1	SPACER, .320X1.005X.179
141	----	1	ARM, NEUTRAL, LH
142	----	1	SHCS, 5/16-24 X .875 (PATCH)
147	1735483SM	1	SPRING, Extension
157	----	1	KIT, GEROTOR SEAL
158	5104822X3	1	CAP, AXLE, ZT-3400, 53501
159	----	1	SPRING, TORSION, CW
164	----	1	WASHER, 1.355 x 2.035 x .021 FLAT

# Transaxle Service Parts - 84008004 & 84007997

Note: Unless noted otherwise, use the standard torque specifications

Mfg. No: 5902052

## Service Parts Schematic for Hydro-Gear® Transaxles:

ZL-HPHH-UL7B-2XLX (84008004)

ZL-LPHH-UL7C-3XLX (84007997)

For components not listed see your authorized Hydro-Gear® service provider.

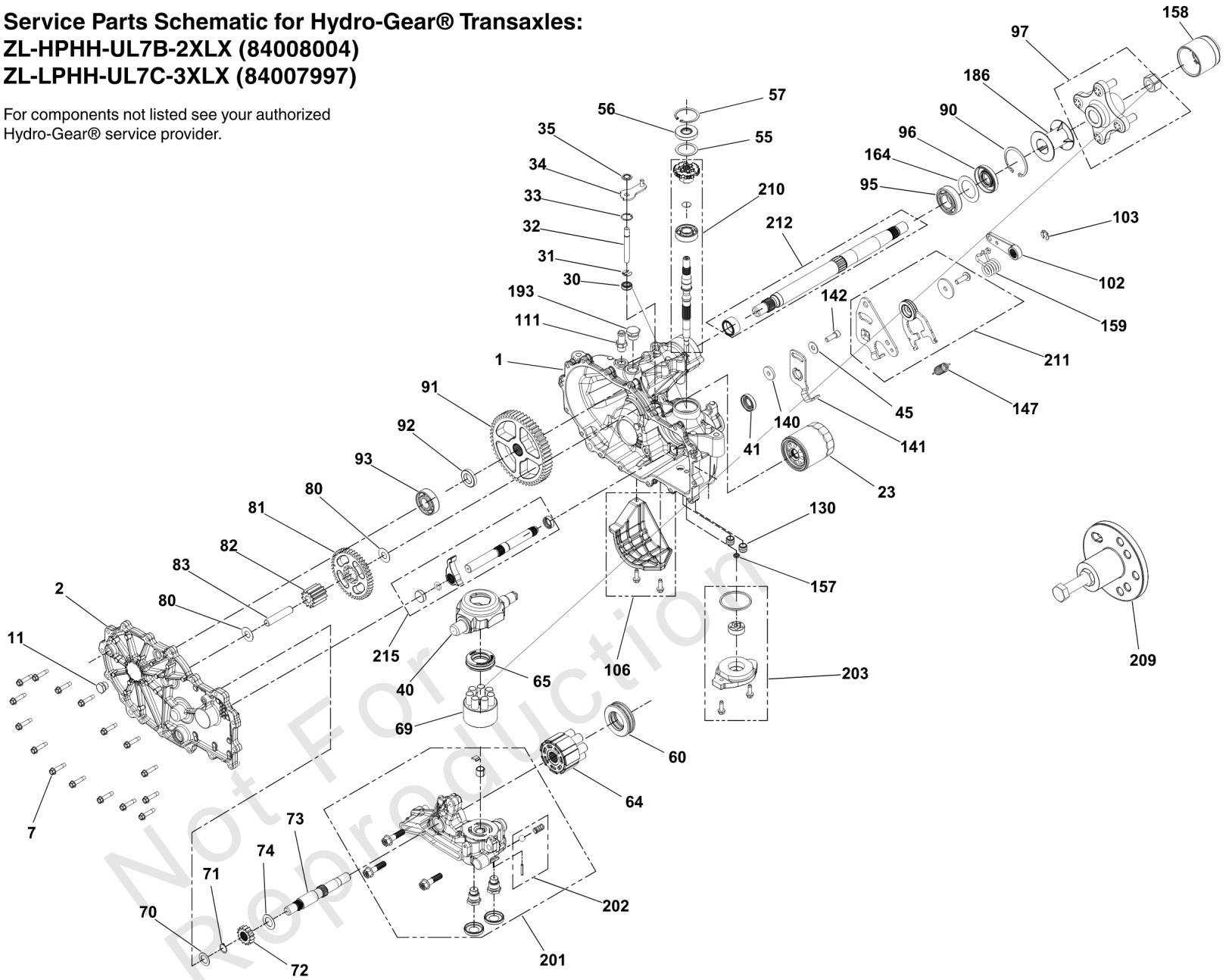

## Transaxle Service Parts - 84008004 & 84007997

REF NO	PART NO	QTY	DESCRIPTION
186	5103589X9	1	DEBRIS GUARD HG #53496
193	-----	1	PLUG, 3/4-16
200	5101026X8SM	1	KIT SEAL
201	-----	1	KIT, CENTER SECTION, LH CHARGE
202	-----	1	KIT, CHARGE RELIEF
203	5105085X1	1	KIT, CHARGE
209	-----	1	KIT, HUB PULLER
210	-----	1	KIT, INPUT SHAFT
211	1735490SM	1	ARM, Control Kit L.H.
212	-----	1	KIT, SHAFT, AXLE
215	-----	1	KIT, OUTBOARD, RH ROT B / LH ROT A

Not For Reproduction

# Transmission Group - Suspension

Note: Unless noted otherwise, use the standard torque specifications

Mfg. No: 5902052

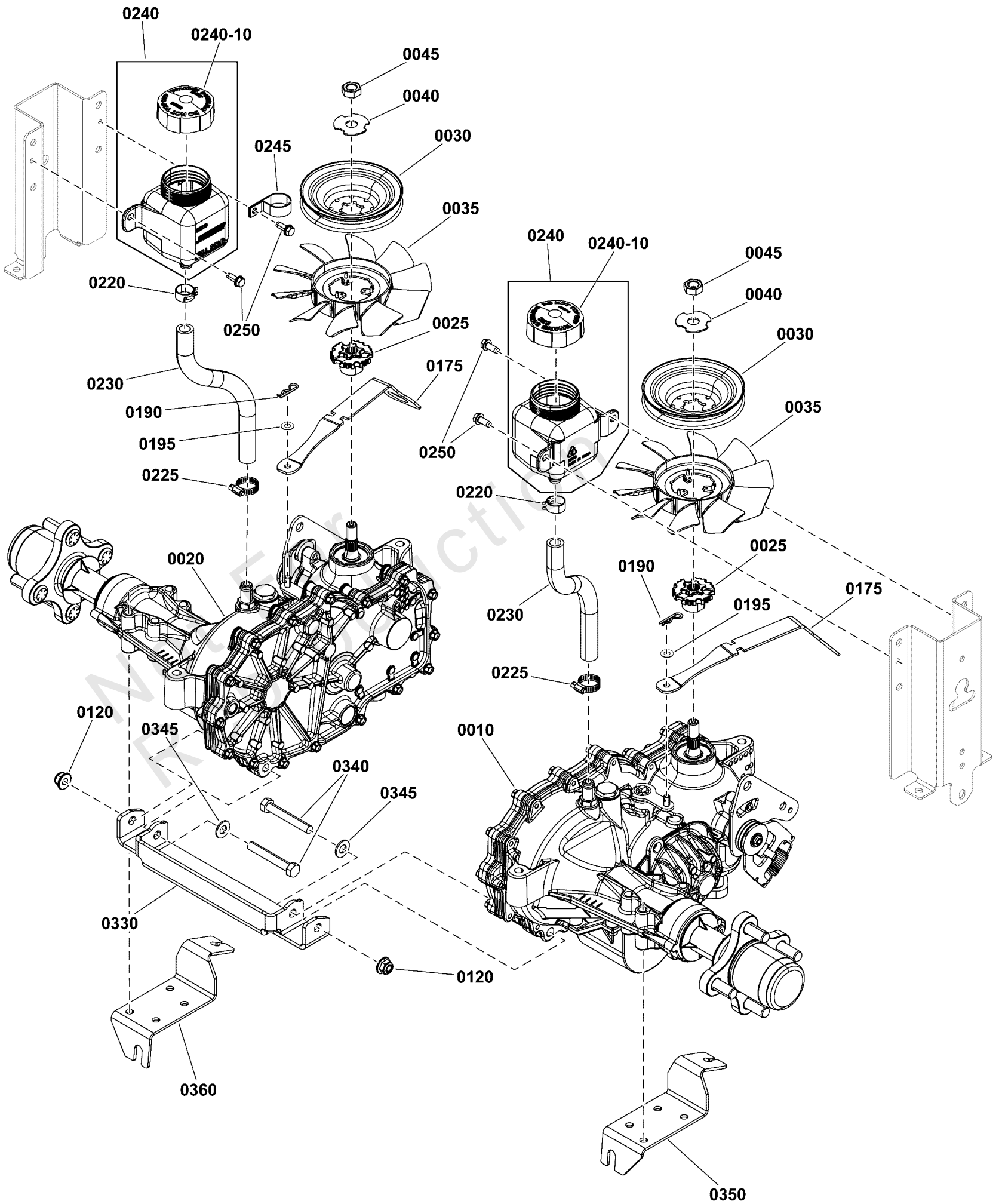

## Transmission Group - Suspension

REF NO	PART NO	QTY	DESCRIPTION
0010	84008004	1	TRANSAXLE -(Left side)(Refer to Note: *)
0020	84007997	1	TRANSAXLE -(Right side)(Refer to Note: *)
0025	84003847	2	HUB
0030	1759447YP	2	PULLEY, Transmission
0035	84007455	2	FAN
0040	5102914YP	2	WASHER, ZT5400, SLOTT
0045	5102916YP	2	NUT, ZT5400 -(Torque to 45 - 55 ft-lbs (61 - 75,6 Nm))
0120	5025394SM	2	NUT, 3/8-16 HEX NYLOCK
0175	1759276AYP	2	VALVE-TOW
0190	703430	2	PIN, 13X1.19
0195	703332	2	WASHER
0220	5025474SM	2	CLAMP - HOSE
0225	5021392SM	2	CLAMP, #6 HOSE, STAIN
0230	5050857X10FS	2	HOSE
0240	5100473SM	2	RESERVOIR -(Includes item # 0240-10.)
0240-10	5100778X1YP	2	RESERVIOR CAP (SV)
0245	5021500FS	1	CLAMP -(This clamp is mounted on the left side of the unit for Briggs & Stratton powered models.)
0250	703054	4	SCREW, 1/4-20X0.625
0330	1759172AYP	1	SUPPORT
0340	84007037	2	BOLT
0345	5025156FS	2	WASHER
0350	84006958	1	BRACKET
0360	84006959	1	BRACKET

### Footnotes:

Note: \*See your local Hydro Gear dealer for parts and service.

# Wheel & Tire Group

Note: Unless noted otherwise, use the standard torque specifications

Mfg. No: 5902052

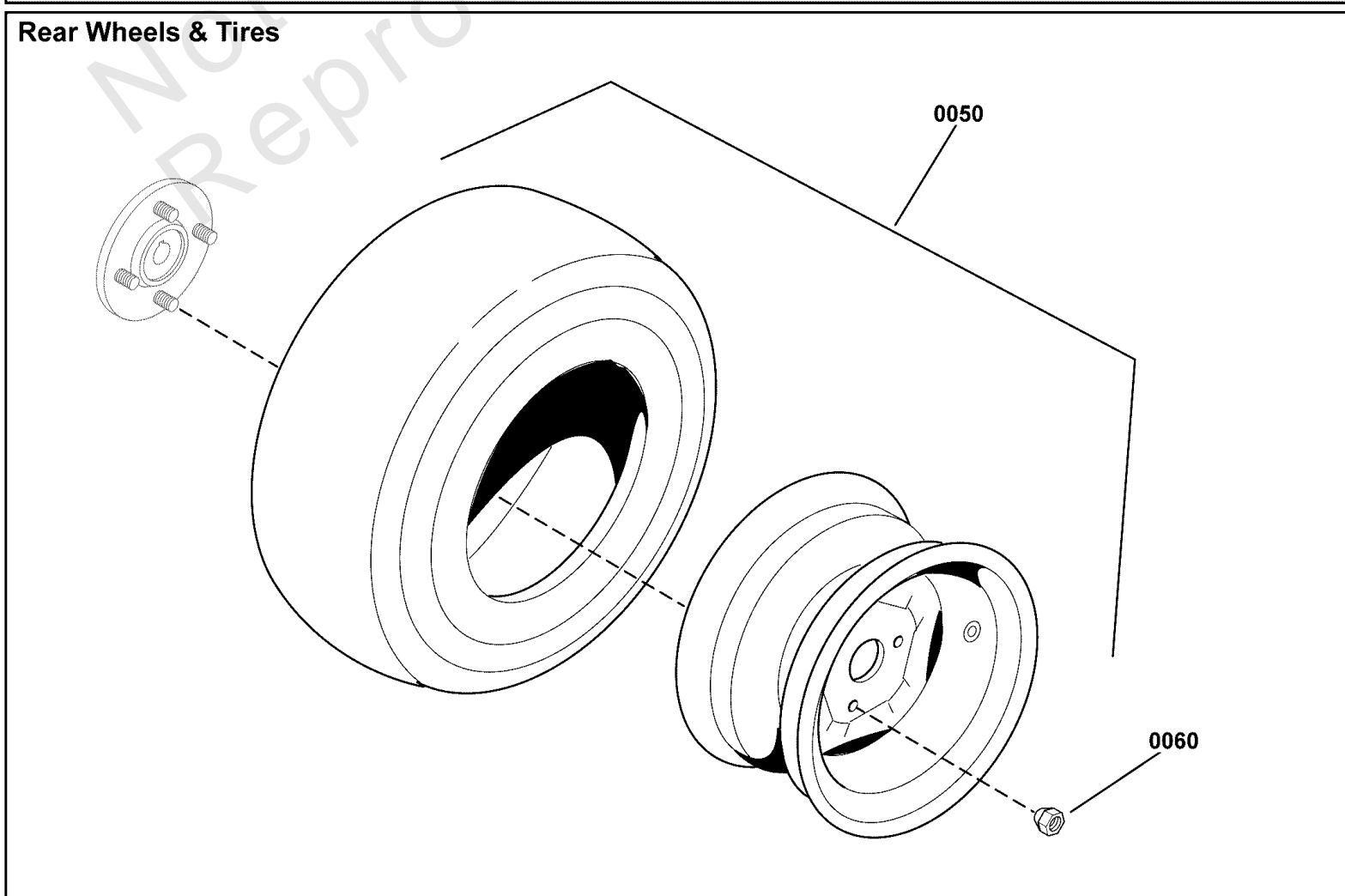
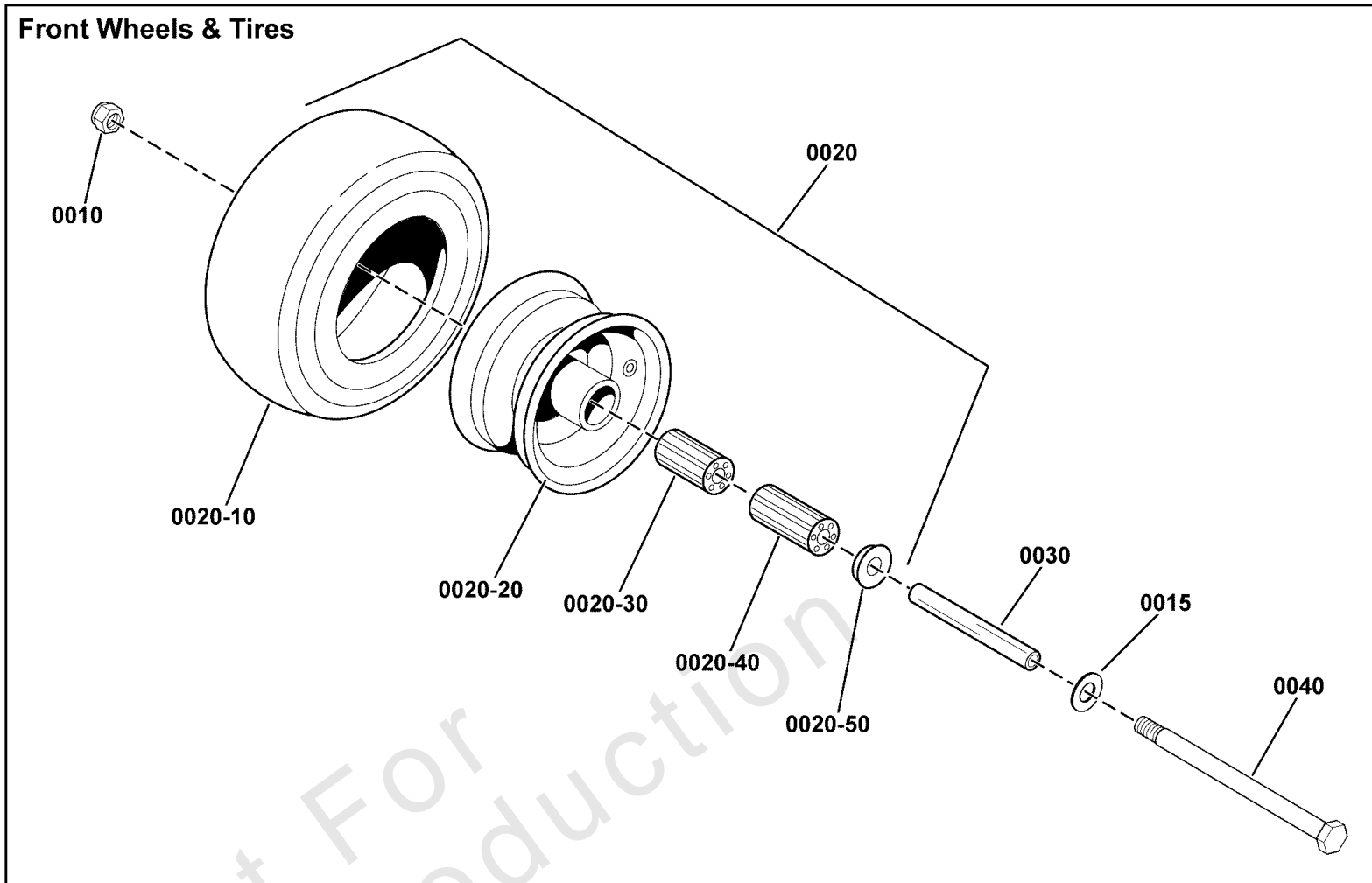



## Wheel & Tire Group

REF NO	PART NO	QTY	DESCRIPTION
0010	5025396	2	NUT, Hex Flange, Nylock, 1/2-13
0015	5025158	2	WASHER, 1/2 SAE
0020	5109055FS	2	TIRE ASSEMBLY
0020-10	5022577	2	TIRE, RUBBER ONLY
0020-20	-----	2	WHEEL RIM
0020-30	84008029	2	BEARING
0020-40	5021182	2	BEARING, ROLLER 3/4" ID X 3.25" (ONE PER TIRE)(SV)
0020-50	5021043	2	RETAINER, BEARING (TWO PER TIRE)(SV)
0030	5106587	2	CASTER AXLE SHAFT, .51"ID X .75"OD X7.16
0040	5025017X72	2	BOLT, 1/2-13 X 9" GD5 YZ
0050	80094605	2	WHEEL AND TIRE ASSY, 22X11-10 (BLACK)
0060	5020601	8	NUT, 1/2-20, FOR WHEEL BOLT SILVER

Not For Reproduction

# Hardware Identification & Torque Specifications

Torque Specification Chart								
FOR STANDARD METRIC MACHINE HARDWARE (Tolerance ± 20%)								
Property Class	5.6		8.8		10.9		12.9	
	Class 5.6		Class 8.8		Class 10.9		Class 12.9	
Size Of Hardware	in/lbs	Nm.	in/lbs	Nm.	in/lbs	Nm.	in/lbs	Nm.
	ft/lbs		ft/lbs		ft/lbs		ft/lbs	
M3	5.88	.56	13.44	1.28	19.2	1.80	22.92	2.15
M4	13.44	1.28	30.72	2.90	43.44	4.10	52.56	4.95
M5	26.4	2.50	60.96	5.75	5.97	8.10	7.15	9.7
M6	44.64	4.3	7.3	9.9	10.3	14	12.1	16.5
M7	5.2	7.1	12.1	16.5	16.9	23	19.9	27
M8	7.7	10.5	17.7	24	25	34	29	40
M10	15	21	35	48	50	67	59	81
M12	26	36	61	83	86.2	117	103	140
M14	42	58	101	132	136	185	162	220
M16	64	88	147	200	210	285	250	340
M18	89	121	202	275	287	390	346	470
M20	126	171	290	390	405	550	486	660
M22	169	230	390	530	559	745	656	890
M24	217	295	497	375	708	960	840	1140
M27	320	435	733	995	1032	1400	1239	1680
M30	435	590	995	1350	1401	1900	1681	2280
M33	590	800	1349	1830	1902	2580	2278	3090
M36	759	1030	1740	2360	2441	3310	2935	3980
M39	988	1340	2249	3050	3163	4290	3798	5150

Torque Specification Chart						
FOR STANDARD MACHINE HARDWARE (Tolerance ± 20%)						
Hardware Grade	No Marks		SAE Grade 5		SAE Grade 8	
	SAE Grade 2		SAE Grade 5		SAE Grade 8	
Size Of Hardware	in/lbs	Nm.	in/lbs	Nm.	in/lbs	Nm.
	ft/lbs		ft/lbs		ft/lbs	
8-32	19	2.1	30	3.4	41	4.6
8-36	20	2.3	31	3.5	43	4.9
10-24	27	3.1	43	4.9	60	6.8
10-32	31	3.5	49	5.5	68	7.7
1/4-20	66	7.6	8	10.9	12	16.3
1/4-28	76	8.6	10	13.6	14	19.0
5/16-18	11	15.0	17	23.1	25	34.0
5/16-24	12	16.3	19	25.8	29	34.0
3/8-16	20	27.2	30	40.8	45	61.2
3/8-24	23	31.3	35	47.6	50	68.0
7/16-14	30	40.8	50	68.0	70	95.2
7/16-20	35	47.6	55	74.8	80	108.8
1/2-13	50	68.0	75	102.0	110	149.6
1/2-20	55	74.8	90	122.4	120	163.2
9/16-12	65	88.4	110	149.6	150	204.0
9/16-18	75	102.0	120	163.2	170	231.2
5/8-11	90	122.4	150	204.0	220	299.2
5/8-18	100	136	180	244.8	240	326.4
3/4-10	160	217.6	260	353.6	386	525.0
3/4-16	180	244.8	300	408.0	420	571.2
7/8-9	140	190.4	400	544.0	600	816.0
7/8-14	155	210.8	440	598.4	660	897.6
1-8	220	299.2	580	788.8	900	1,244.0
1-12	240	326.4	640	870.4	1,000	1,360.0

The guides and ruler furnished below are designed to help you select the appropriate hardware.



Nut, M8

Thread Diameter (mm)

Inside Diameter (in)      Threads per inch

Nut, 1/2-16



Screw, M8- 1.25 x 25

Thread Diameter (mm)      Distance between threads (mm)      Body Length (mm)

Body Diameter      Threads per inch      Body Length (in)

Screw, 1/2- 16 x 2



## Standard Hardware Sizing

When a washer or nut is identified as 1/2" (M8), this is the *Nominal size*, meaning the *inside diameter* is 1/2 inch (8mm metric thread diameter); if a second number is present it represents the *threads per inch* (distance between threads).

When bolt or capscrew is identified as 1/2 - 16 x 2" (M8 - 1.25 x 50), this means the *Nominal size*, or body diameter is 1/2 inch (8mm metric thread diameter), the second number, 16, represents the *threads per inch*, (*distance between threads*). The final number is the body length of the bolt or screw, 2 inches (50mm).

## NOTES

- These torque values are to be used for all hardware excluding: locknuts, self-tapping screws, thread forming screws, sheet metal screws and socket head setscrews.
- Recommended seating torque values for locknuts:
  - for prevailing torque locknuts - use 65% of grade 5 torques.
  - for flange whizlock nuts and screws - use 135% of grade 5 torques.
- Unless otherwise noted on assembly drawings, all torque values must meet this specification.

## Common Hardware Types

Hex Head Capscrew



Washer



Carriage Bolt



Hex Nut

## Wrench & Fastener Size Guide

1/4" Bolt or Nut Wrench—7/16"	5/16" Bolt or Nut Wrench—1/2"	3/8" Bolt or Nut Wrench—9/16"	7/16" Bolt or Nut Wrench (Bolt)—5/8" Wrench (Nut)—11/16"	1/2" Bolt or Nut Wrench—3/4"
M6 Bolt or Nut Wrench—10mm	M8 Bolt or Nut Wrench—13mm	M10 Bolt or Nut Wrench—17mm	M12 Bolt or Nut Wrench—19mm	M14 Bolt or Nut Wrench—22mm

