



# Parts Manual

Mfg. No: 5902000  
Rover XC w/ Briggs & Stratton Engine  
(FS1200) Series Stand-On Spreader



5106065 - Salt Spreader Baffle, 220# (SPB-220-2).....  
5106232 - Rover XC Spare Parts Kit (SPK-400-2).....

Not For  
Reproduction

---

<b>Model Components</b>	<b>Page</b>
Decal Group.....	4
Electrical Group.....	6
Electrical Schematic.....	8
Gearbox Group.....	10
Handlebar Group.....	12
Hopper Gate Assembly Group (220 LBS).....	14
Hopper Group (220 LBS).....	16
Main Frame Group S/N: 30000004145 and Below.....	18
Main Frame Group S/N: 30000004146 and Above.....	20
Operator Platform Group.....	22
Power Transmission Group.....	24
Spreader Shield Group.....	26
Torque Specification Chart.....	28

Not For  
Reproduction

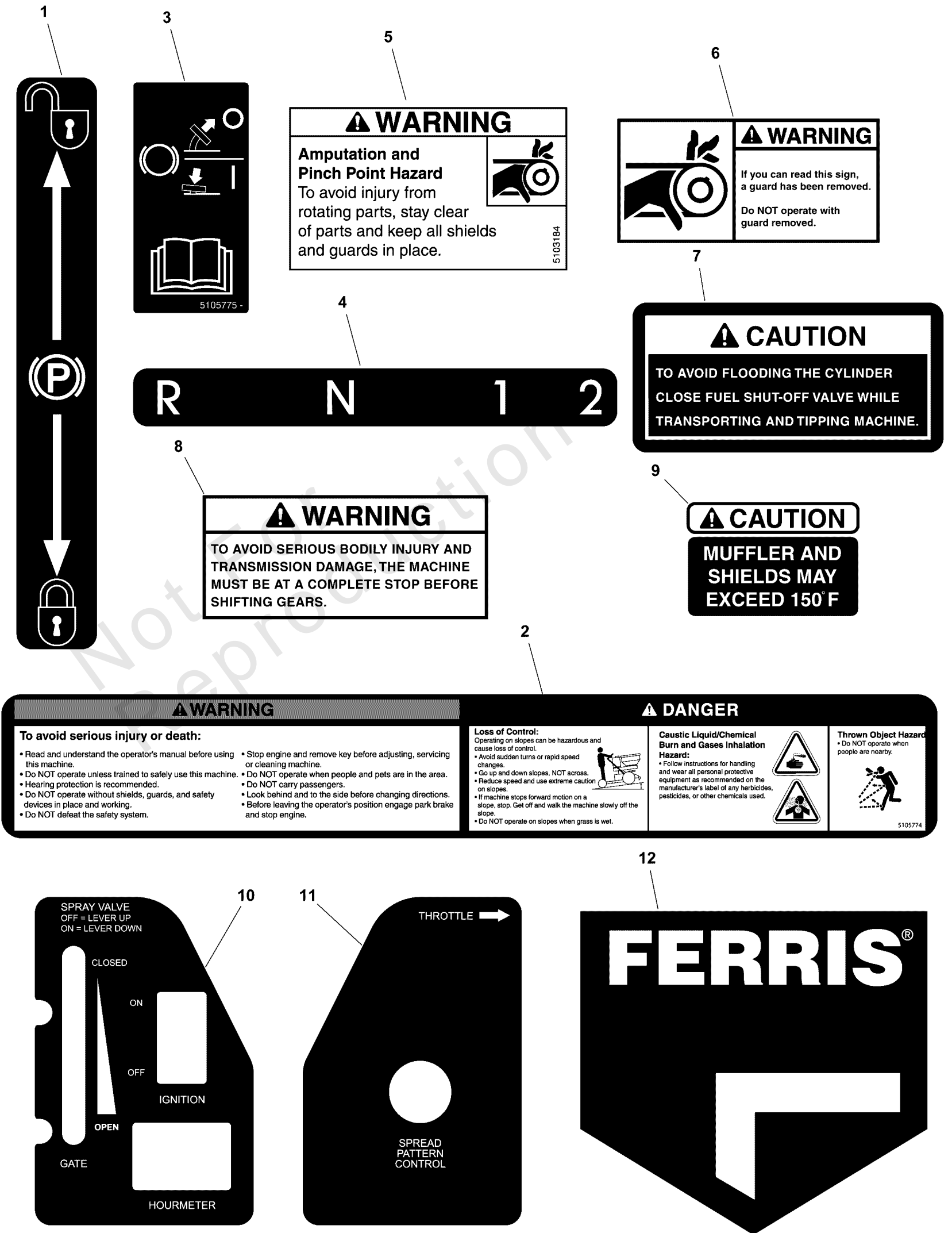

## Decal Group

REF NO	PART NO	QTY	DESCRIPTION
1	5102628	1	DECAL, PARKING BRAKE SYMBOLS
2	5105774	1	DECAL, WARNING / DANGER
3	5105775	1	DECAL, BRAKE PEDAL
4	5106500	1	DECAL, GEAR SELECTOR
5	5103184	3	DECAL, WARNING, HAND IN BELT, ENG ONLY
6	5106504	1	DECAL, WARNING, GUARD
7	5106505	1	DECAL, CAUTION, FLOODING
8	5106506	1	DECAL, WARNING, INJURY & TRANS. DAMAGE
9	5106507	1	DECAL, CAUTION, MUFFLER TEMP.
10	5106508	1	DECAL, CONSOLE, LEFT ROVER
11	5106509	1	DECAL, CONSOLE, RIGHT ROVER
12	5106542	1	DECAL, 3.00" FERRIS SHIELD LOGO

Not For Reproduction

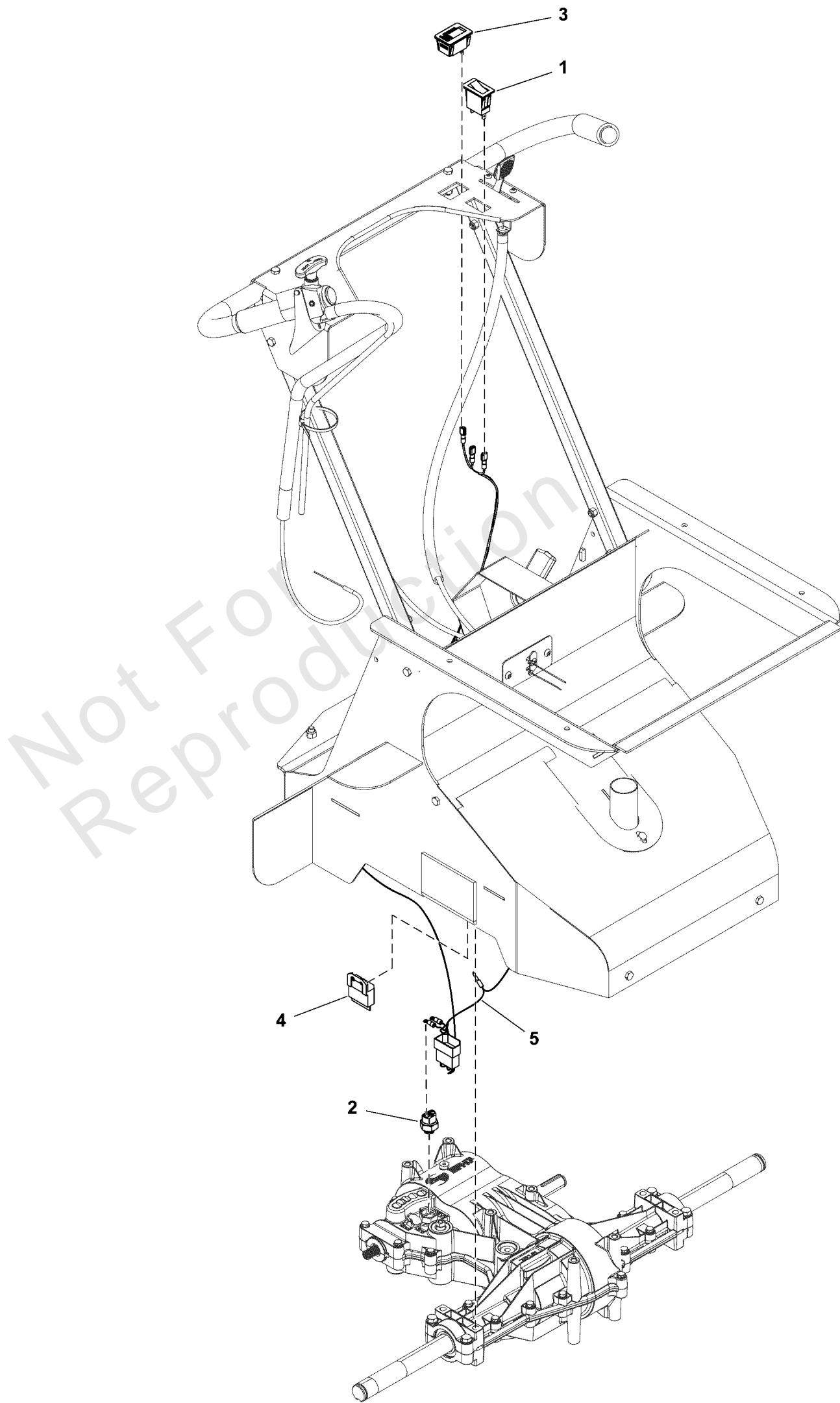

## *Electrical Group*

REF NO	PART NO	QTY	DESCRIPTION
1	5105945	1	SWITCH, ROCKER ON/OFF
2	5106017	1	PEERLESS NEUTRAL START SWITCH
3	5106145	1	METER, TACH/HOUR INDUCTIVE PICKUP
4	84008442	1	MODULE
5	5109867	1	HARNESS, WIRING ROVER POSITIVE VOLTAGE

Not For Reproduction

# Electrical Schematic

Note: Unless noted otherwise, use the standard torque specifications

Mfg. No: 5902000

## 5109867 MAIN WIRE HARNESS

5109867A

(If internal schematic of the switch is not shown, the image of the switch represents the back view of the connector as it is connected to the switch.)

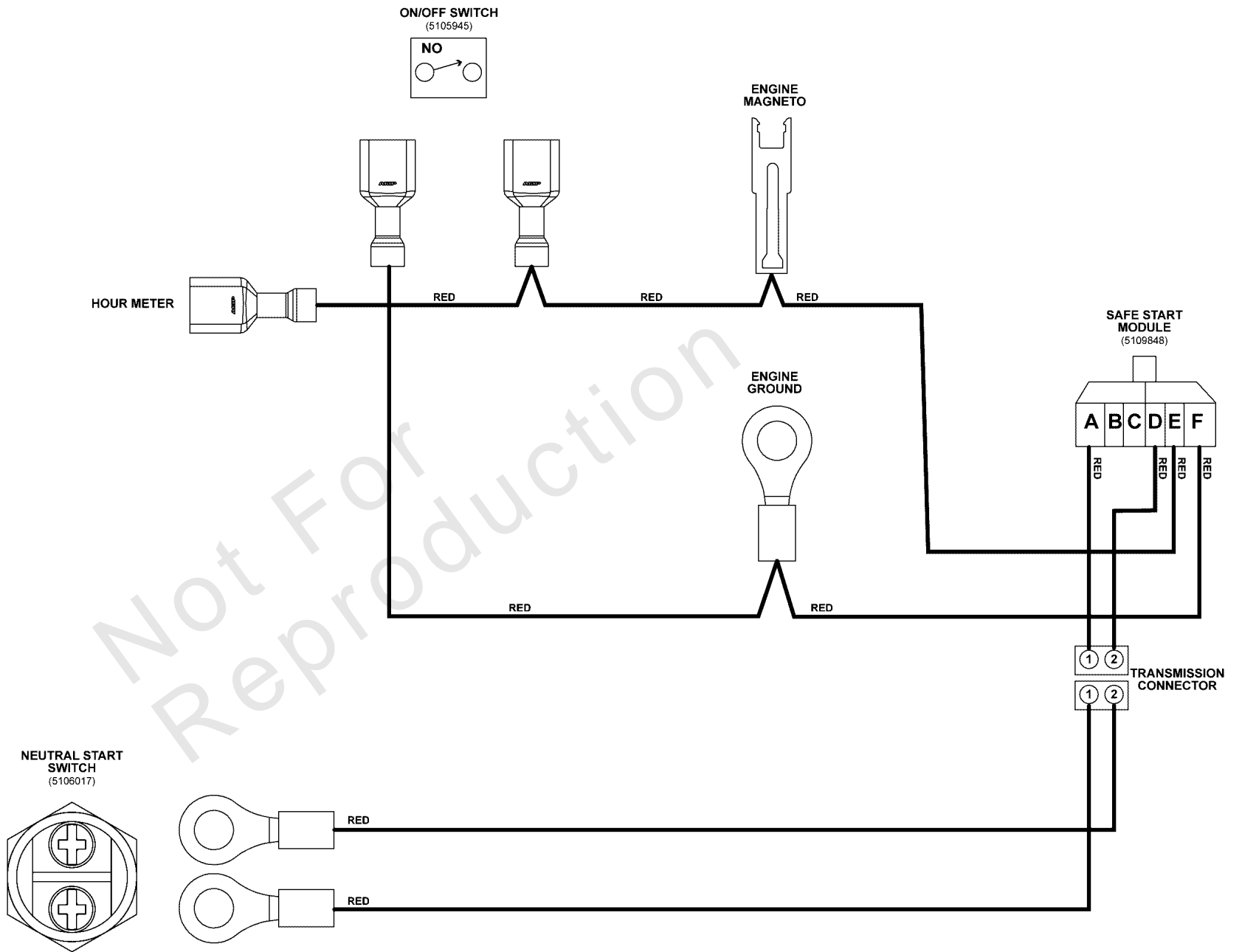



## ***Electrical Schematic***

---

<b>REF NO</b>	<b>PART NO</b>	<b>QTY</b>	<b>DESCRIPTION</b>
5109867	5109867	1	HARNES, WIRING ROVER POSITIVE VOLTAGE
5105945	5105945	1	SWITCH, ROCKER ON/OFF
5109848	84008442	1	MODULE
5106017	5106017	1	PEERLESS NEUTRAL START SWITCH

---

Not For Reproduction

# Gearbox Group

Note: Unless noted otherwise, use the standard torque specifications

Mfg. No: 5902000

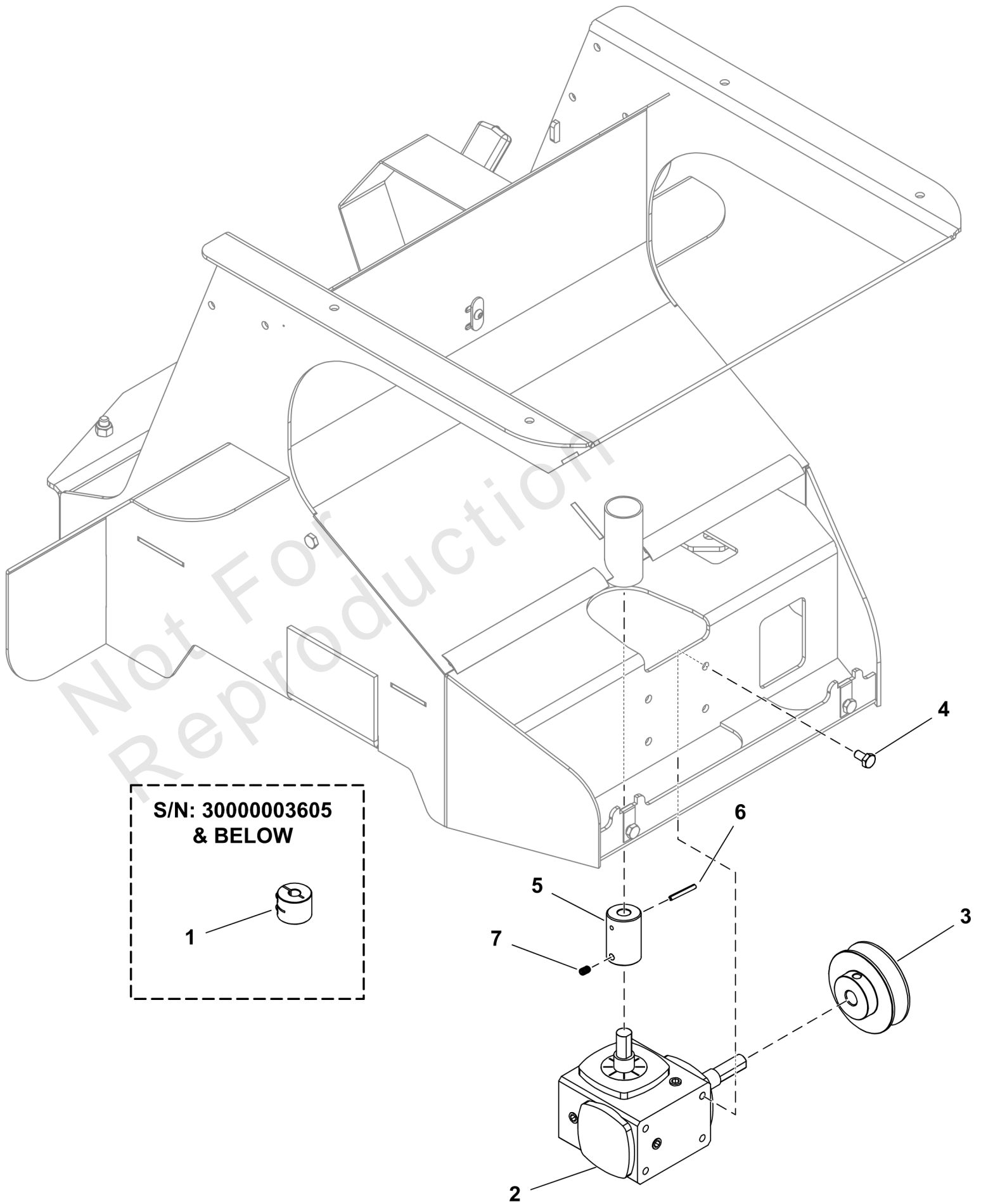

## Gearbox Group

REF NO	PART NO	QTY	DESCRIPTION
1	5601317	1	KIT, PLATTER SHAFT COUPLING -(S/N: 30000003605 and below)(Refer to Note: **)
2	5108269	1	GEAR REDUCER W/ Ø.375" SHAFT -(Refer to Note: *)
2	5105931	1	GEAR REDUCER W/ Ø.500" SHAFT -(Refer to Note: *)
2	5106013	1	GEAR REDUCER W/ 2.50" LONG Ø.500" SHAFT -(Refer to Note: *)
3	5106041	1	PULLEY, 2.95" O.D. x 0.500" I.D. V, A/B
4	5105893	4	SCR-CAP, HEX .250"-20 X .500" SS188
5	5109472	1	COUPLING, SS, PLATTER SHAFT -(S/N: 30000003606 and above)
6	5109473	1	PIN, COILED SPG, SS, .125" DIA X 1.00"LG -(S/N: 30000003606 and above)
7	5109474	1	SCREW, SET, .190" DIA X .3125" LG. 18-8 -(S/N: 30000003606 and above)

Not For  
Reproduction

---

**Footnotes:**

Note: \*Measure the gearbox shafts prior to ordering.

Note: \*\*Kit also includes shaft 5109483.

# Handlebar Group

Note: Unless noted otherwise, use the standard torque specifications

Mfg. No: 5902000

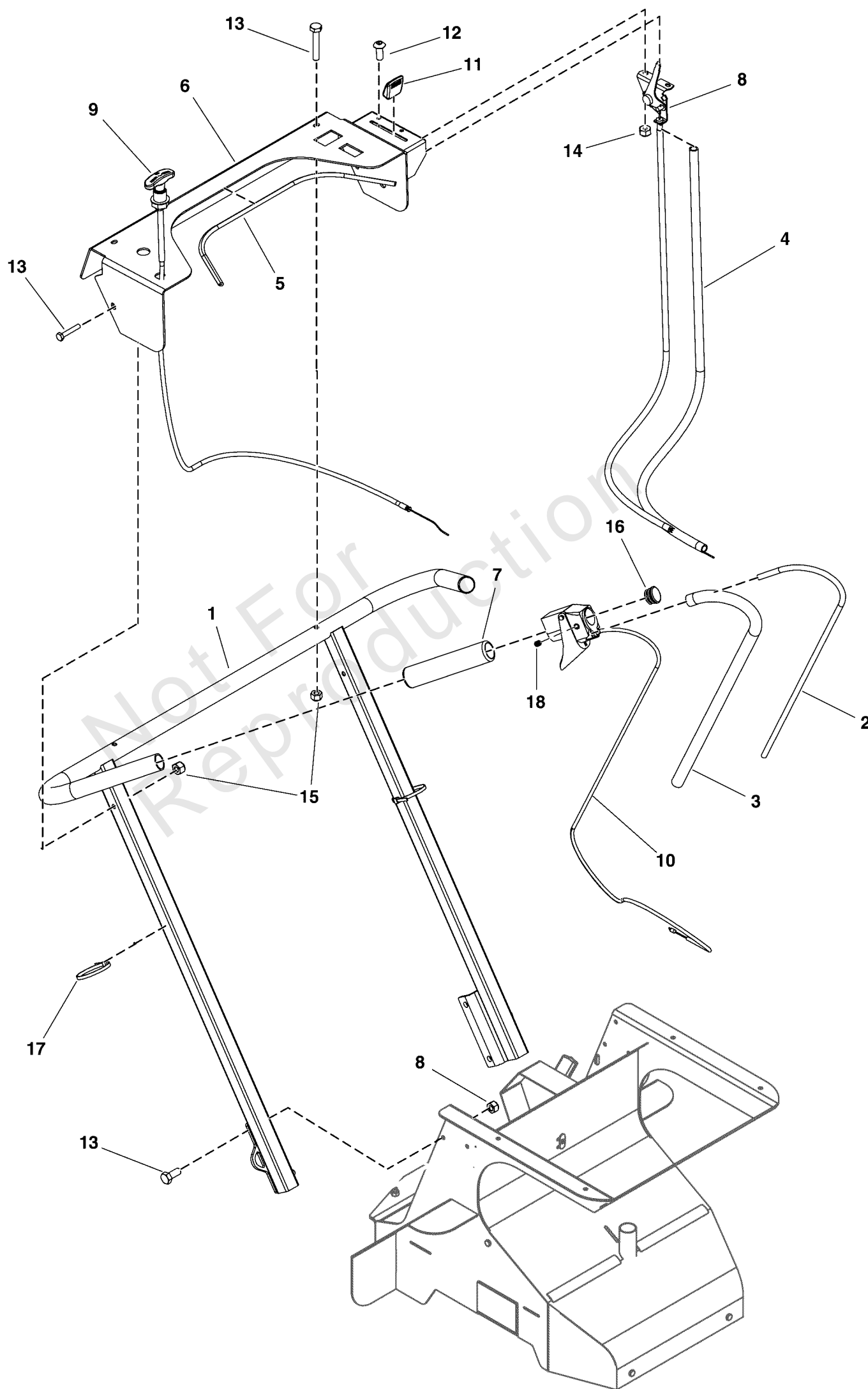

## Handlebar Group

REF NO	PART NO	QTY	DESCRIPTION
1	5417973	1	WELD, HANDLE BAR ROVER
2	5106068	1	ROD,CABLE SUPPORT
3	5106204	1	THROTTLE CABLE SPLIT LOOM, .500" ID
4	5417981	1	SPLIT LOOM, GATE CABLE, 28"
5	5417980	1	TRIM, U-CHANNEL 15.8125" LONG
6	5418082	1	PLATE,CONSOLE ROVER (SANDED)
7	5105928	2	GRIP, .94 ID X .155 THK X 5.75 LONG
8	5109577	1	CABLE, LEVER ACTION 34" -(Connects to gate assembly.)
9	5109576	1	CABLE, TURN TO LOCK, 35" -(Connects to gate assembly.)
10	5601316	1	KIT, ROVER/PATHFINDER THROTTLE CABLE -(Connects to engine.)
11	5106000	1	KNOB, GATE LEVER
12	5105978	2	SCR-CAP, BSH #10-24 X .500" SS188
13	5106021	8	SCR-CAP, HEX .250"-20 X 1.500" SSF593C
14	5105963	2	NUT-HEX-NYLK, #10-24 SS188
15	5106040	8	NUT-HEX-NYLK, .250"-20 SS188
16	5106028	2	PLUG, 1" TUBE, ROUND
17	5106297	2	CABLE TIE, .188" W X 7.50" LNG
18	5106185	1	SCR-SH, SET .3125"-18 X .375" KCPT SS188

# Hopper Gate Assembly Group (220 LBS)

Note: Unless noted otherwise, use the standard torque specifications

Mfg. No: 5902000

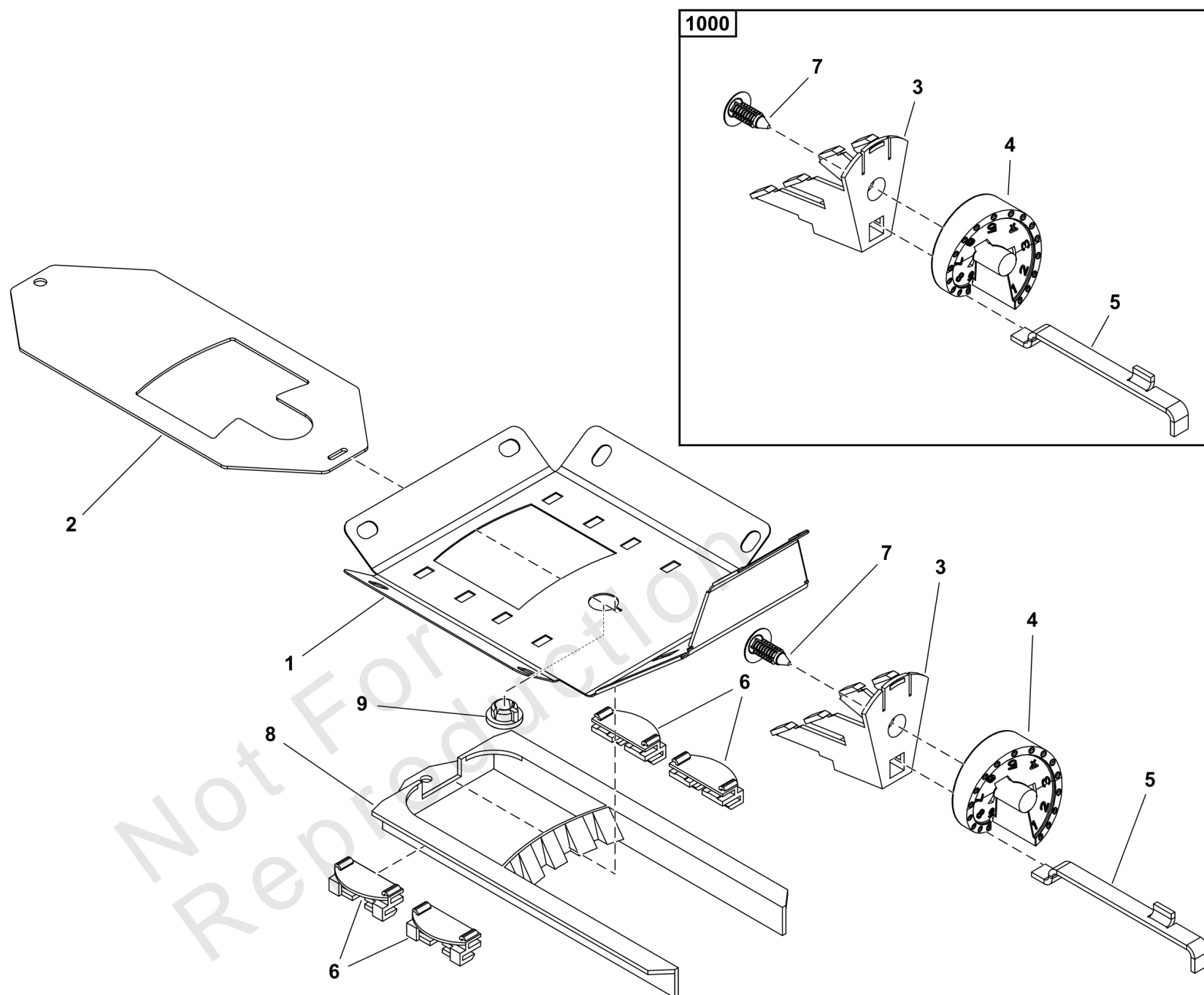

## Hopper Gate Assembly Group (220 LBS)

REF NO	PART NO	QTY	DESCRIPTION
1	5106197	1	PLATE, HOPPER BOTTOM 220 LBS
2	5106199	1	PLATE, RATE GATE
3	5105888	1	MOUNT, SPREADER DIAL
4	5105913	1	DIAL, CONTROLLER
5	5105942	1	PLATE, STOPPER, GATE OPENING
6	5105933	4	GUIDE, RATE GATE & DIFFUSER
7	5105953	1	PINE TREE CLIP, SPREADER FOR DIA .33"
8	5106014	1	BAFFLE, SPREADER DIFFUSER
9	5105878	1	BUSHING, HOPPER SPREADER
1000	5105923	1	AMMS, DIAL MOUNT (S0130) -(Includes items #3, #4, #5, and #7)

Not For Reproduction

# Hopper Group (220 LBS)

Note: Unless noted otherwise, use the standard torque specifications

Mfg. No: 5902000

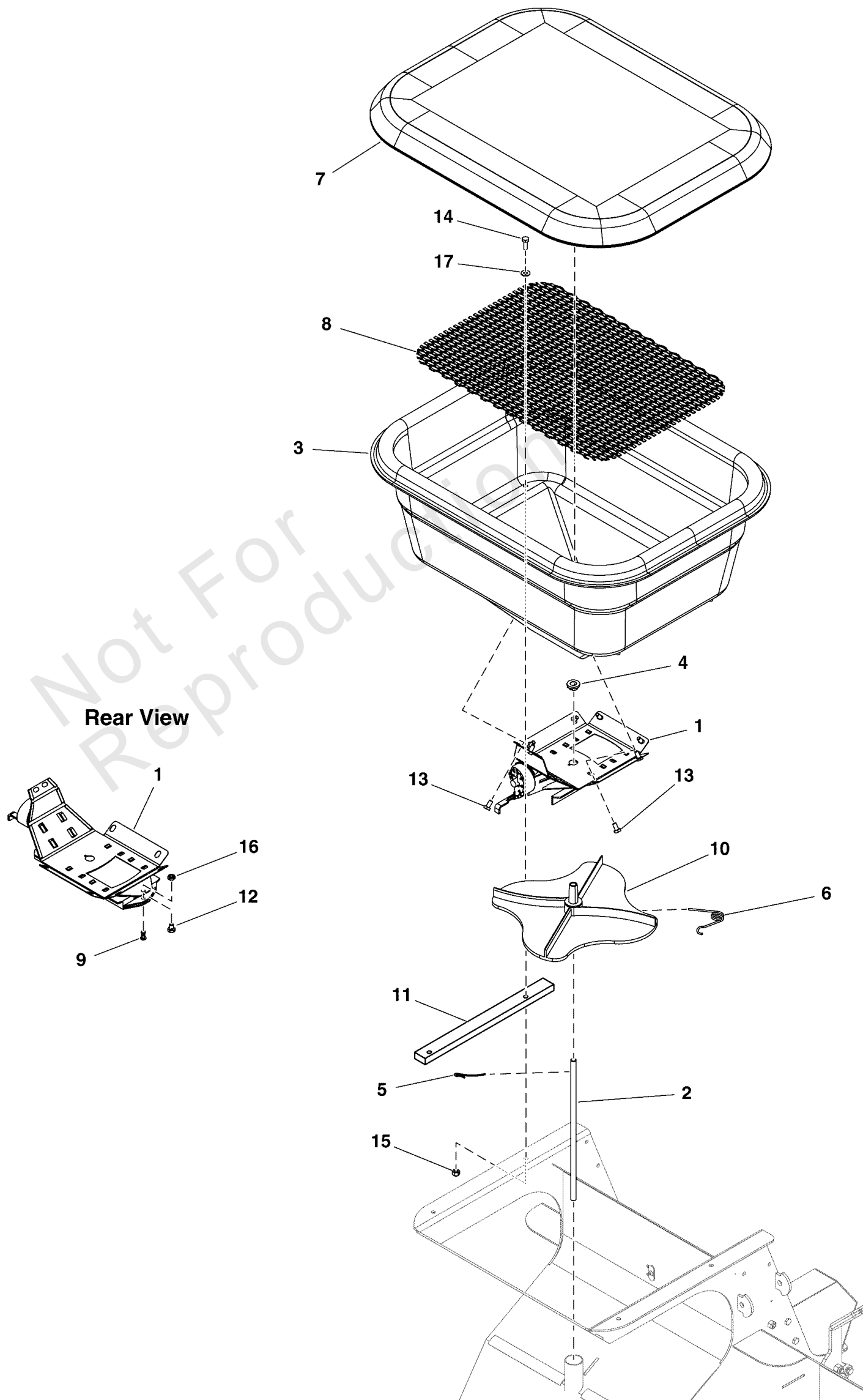



## Hopper Group (220 LBS)

REF NO	PART NO	QTY	DESCRIPTION
1	5601137	1	ASSEMBLY,GATE,COMPLET
2	5601317	1	KIT, PLATTER SHAFT COUPLING -(S/N: 30000003605 and below)(Refer to Note: *)
2	84008078	1	SHAFT, Platter -(S/N: 30000003606 and above)
3	5106211	1	HOPPER, 220 LBS
4	5105878	1	BUSHING, HOPPER SPREADER
5	5105875	1	CLIP, SPINNER AGITATOR
6	5105879	1	CLIP, SPREADER SPINNER
7	5105887	1	COVER, HOPPER, MODEL 220
8	84011455	1	SCREEN, Hopper (MODEL 220 LBS PERF)
9	5105921	1	FITTING, SWIVEL ACCUWAY
10	84008796	1	PLATTER, Spinner
11	5106236	2	SPACER, ROVER XC HOPPER
12	5105894	1	SCR-CAP, HEX .250"-20 X .375" SS188 SPC
13	5105893	8	SCR-CAP, HEX .250"-20 X .500" SS188
14	5106021	4	SCR-CAP, HEX .250"-20 X 1.500" SSF593C
15	5106040	4	NUT-HEX-NYLK, .250"-20 SS188
16	5105915	1	NUT-HEX-NYLK, .250"-20 TH SS188
17	5106067	4	WSHR-STL, FLT .281" X .625" X .050" IS SS188

---

**Footnotes:**

Note: \*Also includes 5109472, 5109473, and 5109474.

# Main Frame Group S/N: 3000004145 and Below

Note: Unless noted otherwise, use the standard torque specifications

Mfg. No: 5902000

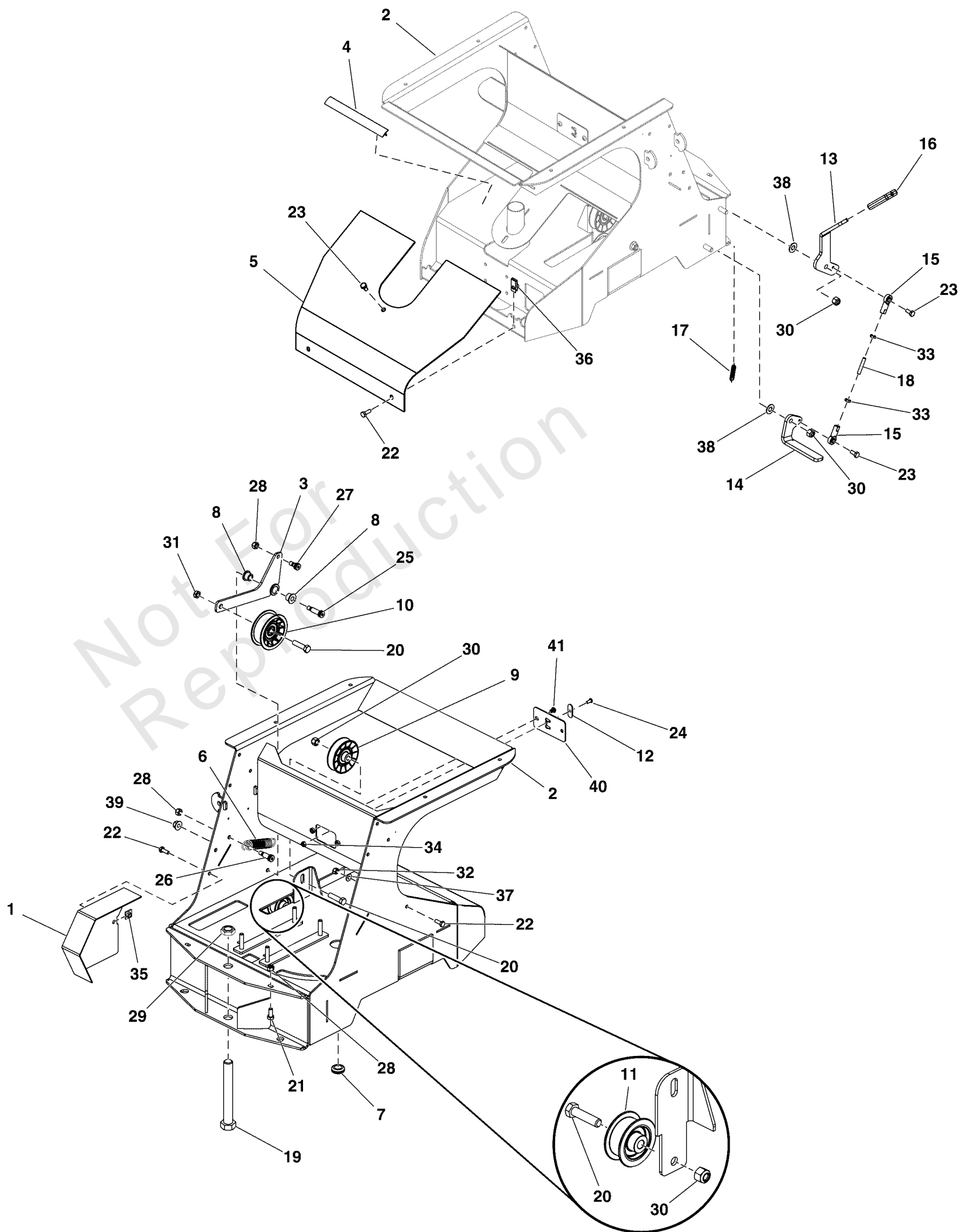

**Main Frame Group S/N: 30000004145 and Below**

REF NO	PART NO	QTY	DESCRIPTION
1	5421498	1	WELD, PULLEY GUARD, ROVER
2	5421482	1	WELD, FRAME ROVER
3	5106139	1	WELD, ARM IDLER ROVER
4	5417982	2	SEAL TRIM, FRONT COWL 7" LONG
5	5418386	1	FRONT COWL, ROVER (SANDED)
6	5105946	1	SPRING, EXTENSION .840" OD X 4.00" LONG SS
7	5107562	1	GROMMET 1.00" I.D. FIT 1.38"HOLE
8	5108816	2	BSHG-FL, .500" X .625" X .500", .875"x .062" IR
9	5106169	1	PULLEY V-BELT IDLER 1.79" OD X 3/8" BORE
10	5106048	1	PULLEY IDLER 2.75" OD X 3/8" BORE
11	5105890	1	PULLEY IDLER 1.75" OD X 3/8" BORE
12	5105969	1	PLATE, CABLE HOLDER
13	5417966	1	HANDLE, PARK BRAKE
14	5106280	1	BRACKET, BRAKE BAR
15	5106173	2	ROD END, FEMALE 1/4-28 RH SS PTFE RACE
16	5105900	1	GRIP, .188" X 1.00" ID X .150" THK CLSD CELL FOAM
17	84010268	1	SPRING, Extension
18	5106174	1	ROD, THREADED .250"-28 X 1.500" SS188
19	5106215	1	SCR-CAP, HEX .750"-10 X 6.000" SS188
20	5106069	3	SCR-CAP, HEX .375"-16 X 1.500" SS188
21	5106024	1	SCR-CAP, HEX .3125"-18 X .750" SS188
22	5106214	5	SCR-CAP, HEX .250"-20 X .750" SS188
23	5106029	3	SCR-CAP, HEX .250"-20 X .625" SS188
24	5105978	1	SCR-CAP, BSH #10-24 X .500" SS188
25	5107641	1	BLT-SLDR, SH.50"X1.25", .375"-16X.63"SS188
26	5106172	1	BLT-SLDR, SH .38"X0.75,.313-18 X.50 SS
27	5106171	1	BLT-SLDR, SH .375" X 0.250", .3125"-18 X.500" SS188
28	5105992	4	NUT-HEX-NYLK, 0.3125"-18 SS188
29	5106184	1	NUT-HEX-NYLK, .750"-10 TH GA ZP
30	5106006	4	NUT-HEX-NYLK, .375"-16 SS188
31	5106579	1	NUT-HEX-NYLK, .375"-16 TH SS188
32	5106040	1	NUT-HEX-NYLK, .250"-20 SS188
33	5106016	2	NUT-HEX, JAM .250"-28 SS188
34	5105963	1	NUT-HEX-NYLK, #10-24 SS188
35	5105973	2	NUT-CLIP, .250"-20 X .375" EDGE DISTANCE
36	5105898	2	NUT-CLIP .250"-20 X .781" EDGE DISTANCE
37	5106067	1	WSHR-STL, FLT .281" X .625" X .050" IS SS188
38	5106168	2	WSHR-STL, FLT .406" X .875" X .050" IS SS188
39	5107638	1	NUT-HEX-NYLK, FLG .375"-16 SS188
40	5419900	1	PLATE, HOPPER CABLES
41	5108320	2	SCR-CAP, SBH .250"-20 X .375" SS188

# Main Frame Group S/N: 3000004146 and Above

Note: Unless noted otherwise, use the standard torque specifications

Mfg. No: 5902000

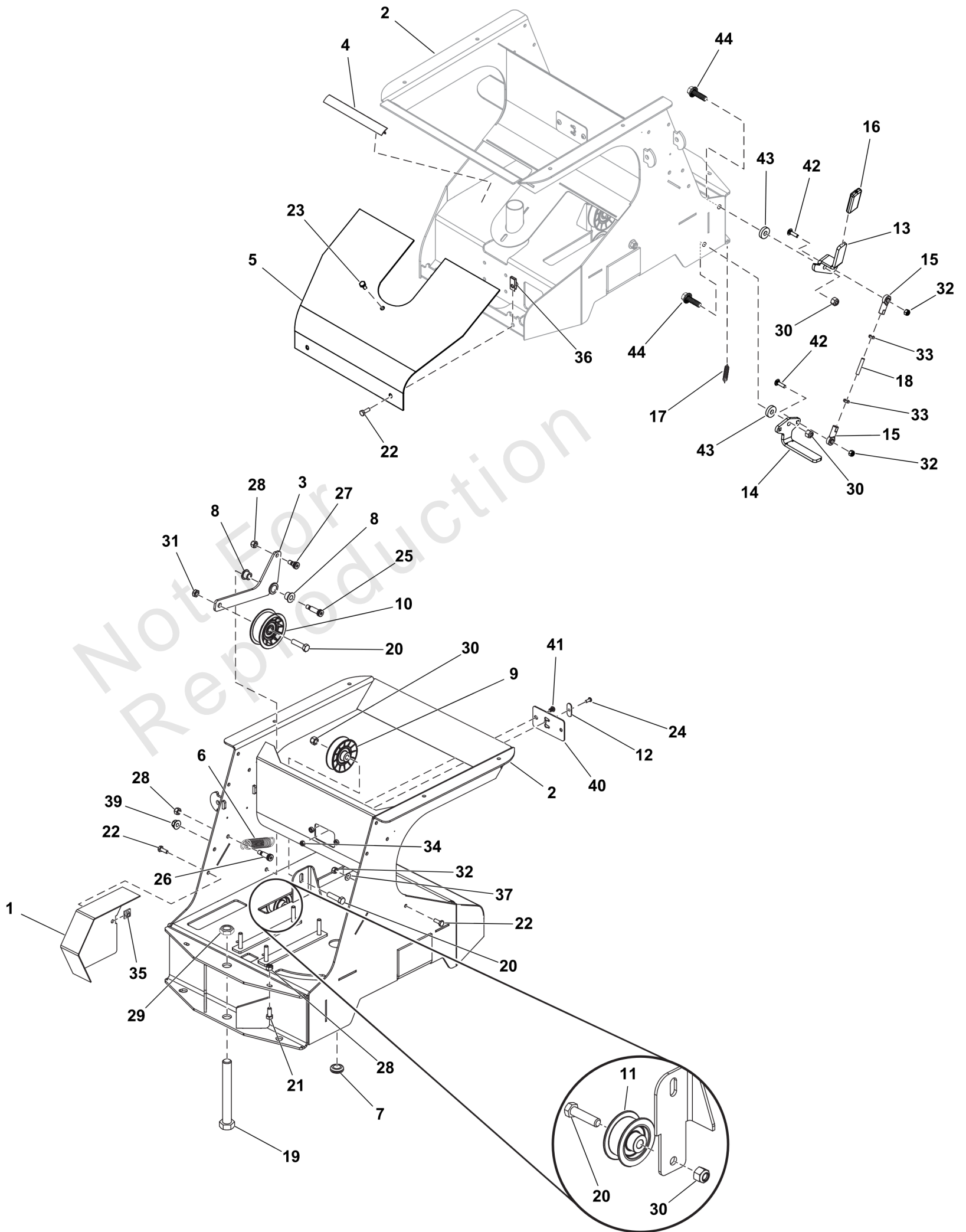

## Main Frame Group S/N: 30000004146 and Above

REF NO	PART NO	QTY	DESCRIPTION
1	5421498	1	WELD, PULLEY GUARD, ROVER
2	-----	1	FRAME
3	5106139	1	WELD, ARM IDLER ROVER
4	5417982	2	SEAL TRIM, FRONT COWL 7" LONG
5	5418386	1	FRONT COWL, ROVER (SANDED)
6	5105946	1	SPRING, EXTENSION .840" OD X 4.00" LONG SS
7	5107562	1	GROMMET 1.00" I.D. FIT 1.38"HOLE
8	5108816	2	BSHG-FL, .500" X .625" X .500", .875"x .062" IR
9	5106169	1	PULLEY V-BELT IDLER 1.79" OD X 3/8" BORE
10	5106048	1	PULLEY IDLER 2.75" OD X 3/8" BORE
11	5105890	1	PULLEY IDLER 1.75" OD X 3/8" BORE
12	5105969	1	PLATE, CABLE HOLDER
13	84008426	1	HANDLE, LH
14	84008428	1	ARM, Brake
15	5106173	2	ROD END, FEMALE 1/4-28 RH SS PTFE RACE
16	5105900	1	GRIP, .188" X 1.00" ID X .150" THK CLSD CELL FOAM
17	84010268	1	SPRING, Extension
18	5106174	1	ROD, THREADED .250"-28 X 1.500" SS188
19	5106215	1	SCR-CAP, HEX .750"-10 X 6.000" SS188
20	5106069	3	SCR-CAP, HEX .375"-16 X 1.500" SS188
21	5106024	1	SCR-CAP, HEX .3125"-18 X .750" SS188
22	5106214	5	SCR-CAP, HEX .250"-20 X .750" SS188
23	5106029	3	SCR-CAP, HEX .250"-20 X .625" SS188
24	5105978	1	SCR-CAP, BSH #10-24 X .500" SS188
25	5107641	1	BLT-SLDR, SH.50"X1.25", .375"-16X.63"SS188
26	5106172	1	BLT-SLDR, SH .38"X0.75,.313-18 X.50 SS
27	5106171	1	BLT-SLDR, SH .375" X 0.250", .3125"-18 X.500" SS188
28	5105992	4	NUT-HEX-NYLK, 0.3125"-18 SS188
29	5106184	1	NUT-HEX-NYLK, .750"-10 TH GA ZP
30	5106006	4	NUT-HEX-NYLK, .375"-16 SS188
31	5106579	1	NUT-HEX-NYLK, .375"-16 TH SS188
32	5106040	3	NUT-HEX-NYLK, .250"-20 SS188
33	5106016	2	NUT-HEX, JAM .250"-28 SS188
34	5105963	1	NUT-HEX-NYLK, #10-24 SS188
35	5105973	2	NUT-CLIP, .250"-20 X .375" EDGE DISTANCE
36	5105898	2	NUT-CLIP .250"-20 X .781" EDGE DISTANCE
37	5106067	1	WSHR-STL, FLT .281" X .625" X .050" IS SS188
39	5107638	1	NUT-HEX-NYLK, FLG .375"-16 SS188
40	5419900	1	PLATE, HOPPER CABLES
41	5108320	2	SCR-CAP, SBH .250"-20 X .375" SS188
42	5107668	2	BLT-RDHDSQNK, .250"-20 X 1.000" SS188
43	84008430	2	SPACER
44	5107616	2	SCR-CAP, HSWH .375"-16 X 1.250" SS188

# Operator Platform Group

Note: Unless noted otherwise, use the standard torque specifications

Mfg. No: 5902000

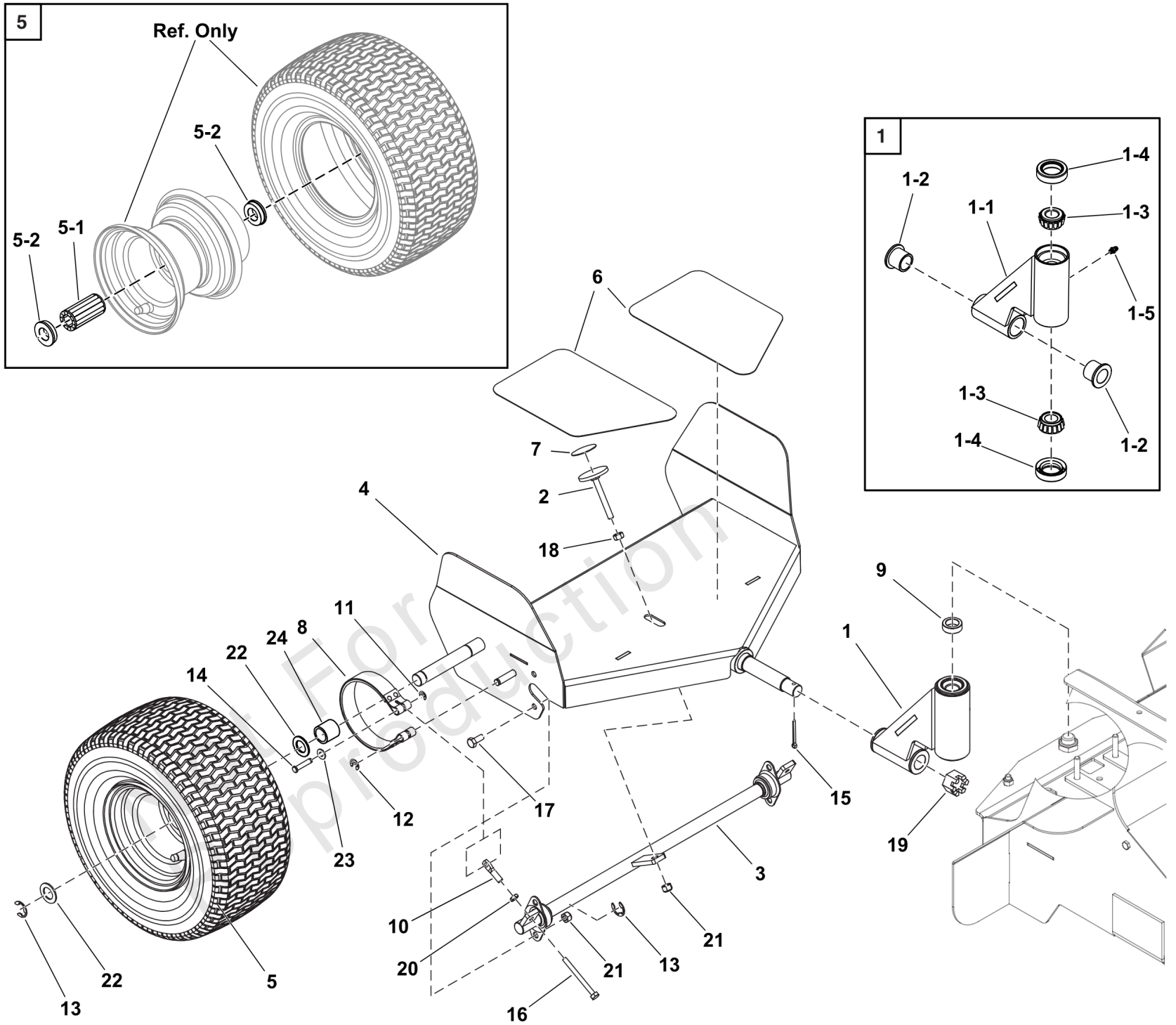

## Operator Platform Group

REF NO	PART NO	QTY	DESCRIPTION
1	-----	1	ASSM, TIE, PLATFORM (S0104)
1-1	5417983	1	WELD, HINGE SULKY
1-2	5106004	2	BUSHING, FLANGE 7/8 ID X 1 1/8 OD X 1 LG
1-3	5105967	2	CONE, TPR-ROL Ø.750" ID X Ø1.521" OD x .655" TH
1-4	5105975	2	SEAL, 1.125" BORE X 1.784" OD X 0.469 THK
1-5	5106119	1	ZERK, GREASE .250"-28 SS
2	5106254	1	WELD, BRAKE PEDAL
3	5106270	1	BRAKE SHAFT ASSY, ROVER (S0301)
4	5417972	1	WELD, SULKY FRAME
5	5106759	2	ASM, WHEEL & TIRE 13" X 6.50" - 6 TURF
5-1	5105907	2	BEARING, ROLLER (C0147) -(One per tire)
5-2	5105901	4	RETAINER, BEARING (C0148) -(Two per tire)
6	5105929	1	PADS, NON-SLIP PLATFORM
7	5417967	1	PAD, NON-SLIP ROUND BRAKE
8	5105910	2	BRAKE, BAND 4.00 INCH
9	5105986	2	SPCR-SS, 303 .750" X 1.125" X .375
10	5105995	2	NUT-EYE .250" 20 X 1.500 OAL ZP
11	5106605	2	E-RING, 0.250" SHAFT SSPH
12	5106047	2	E-RING, 0.375" SHAFT YZ
13	5105882	4	E-RING, .750" SHAFT YZ
14	5105984	2	PIN, CVS .250" X 1.125" SS188
15	5106163	1	PIN-CTR, .156" X 1.500" SS188
16	5025741	1	SCR-CAP, HEX .250"-20 X 2.50" F593C SS
17	5106024	4	SCR-CAP, HEX .3125"-18 X .750" SS188
18	5106159	1	NUT-HEX, .3125"-18 SS188
19	5106203	1	NUT-HEX, CSTL .750"-16 GR2 ZP
20	5105977	2	NUT-HEX, JAM .250"-20 SS188
21	5105992	5	NUT-HEX-NYLK, 0.3125"-18 SS188
22	5105957	4	WSHR-STL, FLT .750"X1.250" X .075" MAB ZP
23	5106067	2	WSHR-STL, FLT .281" X .625" X .050" IS SS188
24	5601299	1	KIT, SULKY WHEEL SPACER -(Includes item #22.)(Refer to Note: *)

### Footnotes:

Note: \*This kit contains parts to do both sides of the unit.

# Power Transmission Group

Note: Unless noted otherwise, use the standard torque specifications

Mfg. No: 5902000

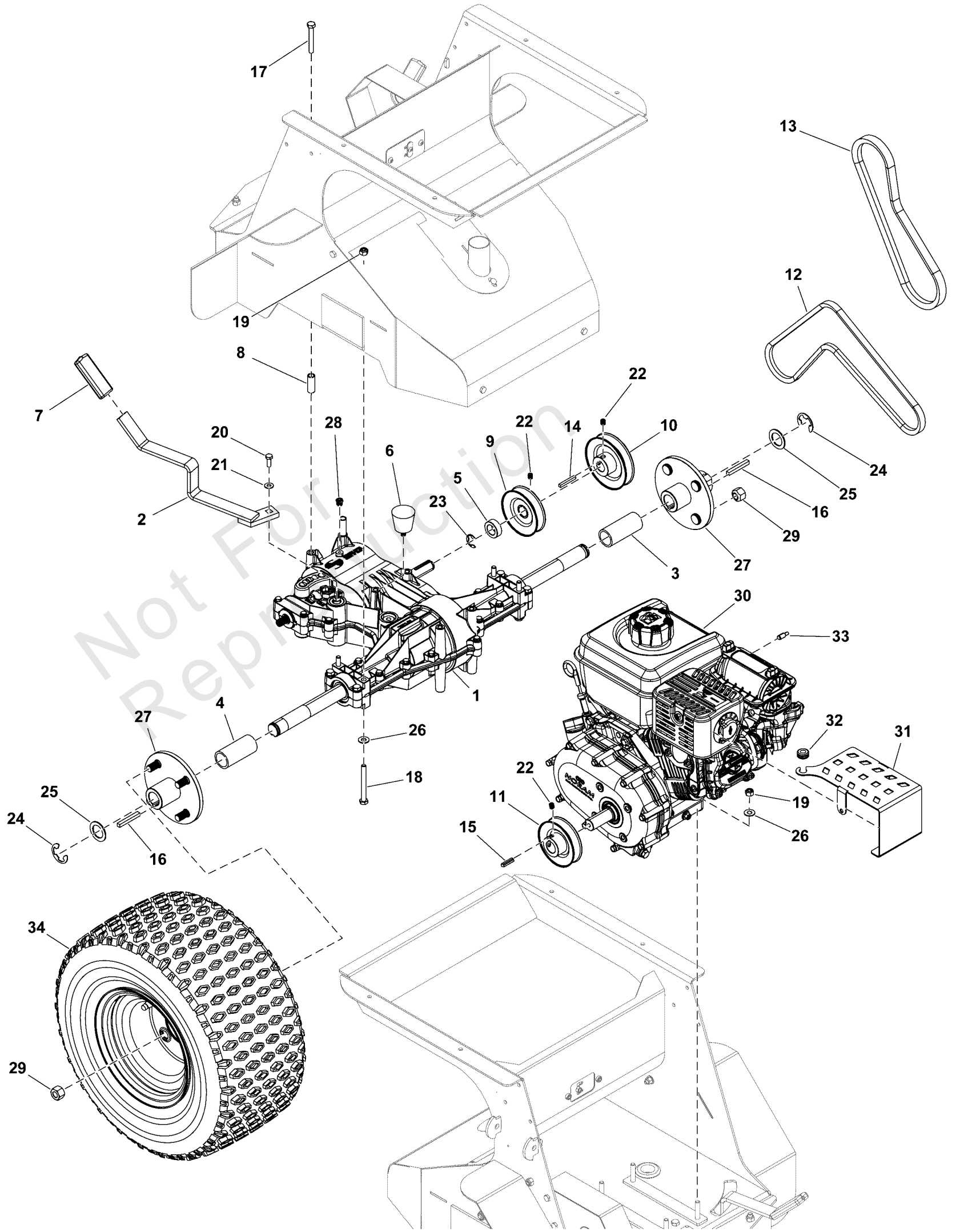



## Power Transmission Group

REF NO	PART NO	QTY	DESCRIPTION
1	5105934	1	TRANSMISSION, PEERLESS 855-007D
2	5106010	1	WELD, LEVER, GEAR SHIFT, ROVER
3	5105976	1	SPCR-PVC 1.049" X 1.315" X 3.000
4	5105991	1	SPCR-PVC 1.049" X 1.315" X 2.850"
5	5106259	1	SPCR-UHMW .765" X 1.250" X .450"
6	5106216	1	BUMPER, 1.188OD X 1.50LG W/.3125-18 STUD
7	5105900	1	GRIP, .188" X 1.00" ID X .150" THK CLSD CELL FOAM
8	5106235	2	SPCR-SS, 304 0.370" X 0.500" X 1.350"
9	5105968	1	PULLEY, 3.50" O.D. x 0.750" I.D. V, A/B
10	5106498	1	PULLEY, 4.00" O.D. x 0.750" I.D. V, A/B
11	5106499	1	PULLEY, 3.50" O.D. x 0.875" I.D. V, A/B -(S/N: 30000003969 and below)
11	84008431	1	PULLEY, Crankshaft -(S/N: 30000003970 and above)
12	5105987	1	BELT, A-SEC, A39
13	5105988	1	BELT, V, B 29.80EL OHR ETH, PLY CD
14	5106038	1	KEY, .188" SQ. X 1.50" SS303
15	5105970	1	KEY, .188"-.250" STEPPED X 1.00" LONG SS 304 -(S/N: 30000003969 and below)
15	84008432	1	KEY, Drive Pulley -(S/N: 30000003970 and above)
16	5105938	2	KEY, .250" SQ. X 2" SS188
17	5106056	2	SCR-CAP, HEX .3125"-18 X 2.250" SS188
18	5105980	4	SCR-CAP, HEX .3125"-18 X 3.000" SS188
19	5105992	8	NUT-HEX-NYLK, 0.3125"-18 SS188
20	5106032	1	SCR-CAP, HEX .250"-28 X 0.750" SS188
21	84008081	1	WSHR-SS, BLV .281"X.875"x.066
22	5106185	6	SCR-SH, SET .3125"-18 X .375" KCPT SS188
23	5105882	1	E-RING, .750" SHAFT YZ
24	5105909	2	E-RING, 1.000" SHAFT YZ
25	5105936	2	WSHR-STL, FLT 1.000"X1.500"X.075" MAB ZP
26	5106009	8	WSHR-STL, FLT .343" X .750" X .050" SPC SS188
27	5105920	2	HUB, 1.00" BORE 4-BOLT X 4.00" BC
28	5106299	1	BREATHER VENT, .125"-27 PFT X .4375" HEX
29	5105964	8	NUT-LUG, .500"-20 ZP
30	----	1	ENGINE, Briggs & Stratton Vanguard 169cc, 10V362-0031-F1
31	5109539	1	PLATE, MUFFLER SHIELD VG160 STAMPED MFLR
32	5106454	1	GROMMET, 0.375" I.D., FIT 0.500" HOLE
33	5108652	1	CONNECTOR, FEMALE BLT 14-16 AWG -(This connector is crimped to an engine wire and the wire harness plugs into it.)
34	5418044	2	ASM, WHEEL&TIRE 18" X 9.50" W/ANTI-FREEZE

# Spreader Shield Group

Note: Unless noted otherwise, use the standard torque specifications

Mfg. No: 5902000

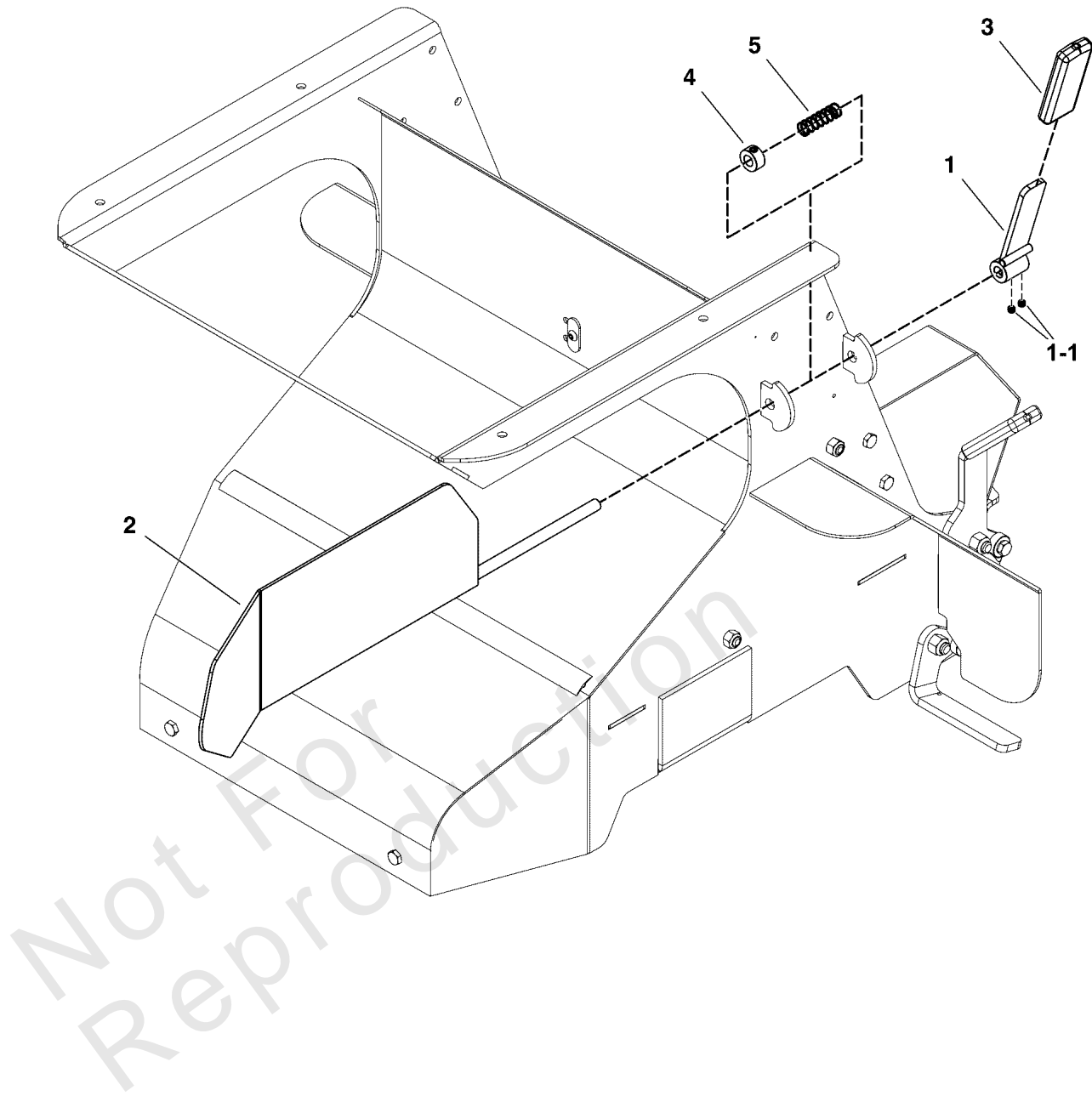

## Spreader Shield Group

REF NO	PART NO	QTY	DESCRIPTION
1	5601516	1	KIT, ROVER DIVERTER HANDLE W/ GRIP -(Includes items #1-1 and 2.)
1-1	-----	2	SET SCREW, 1/4"-20 X 3/16" Hex Socket
2	5106271	1	WELD, DIVERTER ROVER
3	5105900	1	GRIP, .188" X 1.00" ID X .150" THK CLSD CELL FOAM
4	5106023	1	COLLAR, SHAFT .375ID X .750OD X .375WD
5	5106027	1	SPRING, COMPRESSION .480" OD X 1.500 LONG SS

Not For Reproduction

# Hardware Identification & Torque Specifications

Torque Specification Chart								
FOR STANDARD METRIC MACHINE HARDWARE (Tolerance ± 20%)								
Property Class	5.6		8.8		10.9		12.9	
	Class 5.6		Class 8.8		Class 10.9		Class 12.9	
Size Of Hardware	in/lbs	Nm.	in/lbs	Nm.	in/lbs	Nm.	in/lbs	Nm.
	ft/lbs		ft/lbs		ft/lbs		ft/lbs	
M3	5.88	.56	13.44	1.28	19.2	1.80	22.92	2.15
M4	13.44	1.28	30.72	2.90	43.44	4.10	52.56	4.95
M5	26.4	2.50	60.96	5.75	5.97	8.10	7.15	9.7
M6	44.64	4.3	7.3	9.9	10.3	14	12.1	16.5
M7	5.2	7.1	12.1	16.5	16.9	23	19.9	27
M8	7.7	10.5	17.7	24	25	34	29	40
M10	15	21	35	48	50	67	59	81
M12	26	36	61	83	86.2	117	103	140
M14	42	58	101	132	136	185	162	220
M16	64	88	147	200	210	285	250	340
M18	89	121	202	275	287	390	346	470
M20	126	171	290	390	405	550	486	660
M22	169	230	390	530	559	745	656	890
M24	217	295	497	375	708	960	840	1140
M27	320	435	733	995	1032	1400	1239	1680
M30	435	590	995	1350	1401	1900	1681	2280
M33	590	800	1349	1830	1902	2580	2278	3090
M36	759	1030	1740	2360	2441	3310	2935	3980
M39	988	1340	2249	3050	3163	4290	3798	5150

Torque Specification Chart						
FOR STANDARD MACHINE HARDWARE (Tolerance ± 20%)						
Hardware Grade	No Marks		SAE Grade 5		SAE Grade 8	
	SAE Grade 2		SAE Grade 5		SAE Grade 8	
Size Of Hardware	in/lbs	Nm.	in/lbs	Nm.	in/lbs	Nm.
	ft/lbs		ft/lbs		ft/lbs	
8-32	19	2.1	30	3.4	41	4.6
8-36	20	2.3	31	3.5	43	4.9
10-24	27	3.1	43	4.9	60	6.8
10-32	31	3.5	49	5.5	68	7.7
1/4-20	66	7.6	8	10.9	12	16.3
1/4-28	76	8.6	10	13.6	14	19.0
5/16-18	11	15.0	17	23.1	25	34.0
5/16-24	12	16.3	19	25.8	29	34.0
3/8-16	20	27.2	30	40.8	45	61.2
3/8-24	23	31.3	35	47.6	50	68.0
7/16-14	30	40.8	50	68.0	70	95.2
7/16-20	35	47.6	55	74.8	80	108.8
1/2-13	50	68.0	75	102.0	110	149.6
1/2-20	55	74.8	90	122.4	120	163.2
9/16-12	65	88.4	110	149.6	150	204.0
9/16-18	75	102.0	120	163.2	170	231.2
5/8-11	90	122.4	150	204.0	220	299.2
5/8-18	100	136	180	244.8	240	326.4
3/4-10	160	217.6	260	353.6	386	525.0
3/4-16	180	244.8	300	408.0	420	571.2
7/8-9	140	190.4	400	544.0	600	816.0
7/8-14	155	210.8	440	598.4	660	897.6
1-8	220	299.2	580	788.8	900	1,244.0
1-12	240	326.4	640	870.4	1,000	1,360.0

The guides and ruler furnished below are designed to help you select the appropriate hardware.



Nut, M8

Thread Diameter (mm)

Inside Diameter (in)      Threads per inch

Nut, 1/2-16

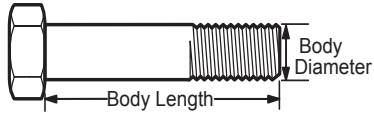

Screw, M8- 1.25 x 25

Thread Diameter (mm)      Distance between threads (mm)      Body Length (mm)

Body Diameter      Threads per inch      Body Length (in)

Screw, 1/2- 16 x 2



## Standard Hardware Sizing

When a washer or nut is identified as 1/2" (M8), this is the *Nominal size*, meaning the *inside diameter* is 1/2 inch (8mm metric thread diameter); if a second number is present it represents the *threads per inch* (distance between threads).

When bolt or capscrew is identified as 1/2 - 16 x 2" (M8 - 1.25 x 50), this means the *Nominal size*, or body diameter is 1/2 inch (8mm metric thread diameter), the second number, 16, represents the *threads per inch*, (*distance between threads*). The final number is the body length of the bolt or screw, 2 inches (50mm).

## NOTES

- These torque values are to be used for all hardware excluding: locknuts, self-tapping screws, thread forming screws, sheet metal screws and socket head setscrews.
- Recommended seating torque values for locknuts:
  - for prevailing torque locknuts - use 65% of grade 5 torques.
  - for flange whizlock nuts and screws - use 135% of grade 5 torques.
- Unless otherwise noted on assembly drawings, all torque values must meet this specification.

## Common Hardware Types

Hex Head Capscrew

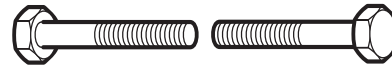

Washer



Carriage Bolt

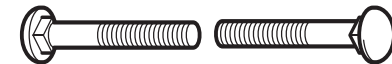

Hex Nut

## Wrench & Fastener Size Guide

1/4" Bolt or Nut Wrench—7/16"	5/16" Bolt or Nut Wrench—1/2"	3/8" Bolt or Nut Wrench—9/16"	7/16" Bolt or Nut Wrench (Bolt)—5/8" Wrench (Nut)—11/16"	1/2" Bolt or Nut Wrench—3/4"
M6 Bolt or Nut Wrench—10mm	M8 Bolt or Nut Wrench—13mm	M10 Bolt or Nut Wrench—17mm	M12 Bolt or Nut Wrench—19mm	M14 Bolt or Nut Wrench—22mm

