



Parts Manual

Mfg. No: 5902094
EZT, 48" FAB, 3.5 VAN, 300e

1696909 - Grass Mulcher Kit, 48" Fabricated Mower Deck.....
1697376A-00 - Bagging Boot, Blade & Baffle, 48".....

Not For
Reproduction

Model Components	Page
48" Mower Deck - Housing, Arbors & Blades Group.....	4
Battery Group.....	6
Body Group.....	8
Controls Group.....	10
Decals Group.....	12
Electrical Group - Main Wiring Harness.....	14
Electrical Group - Onboard Charger and Vehicle Control Module.....	16
Frame Group.....	18
Lift Group.....	20
Parking Brake Group.....	22
Rear Suspension Group.....	24
Seat Group.....	26
Transmission Service Parts.....	28
Wheel & Tire Group.....	30
Torque Specification Chart.....	32

Not For
Reproduction

48" Mower Deck - Housing, Arbors & Blades Group

Note: Unless noted otherwise, use the standard torque specifications

Mfg. No: 5902094

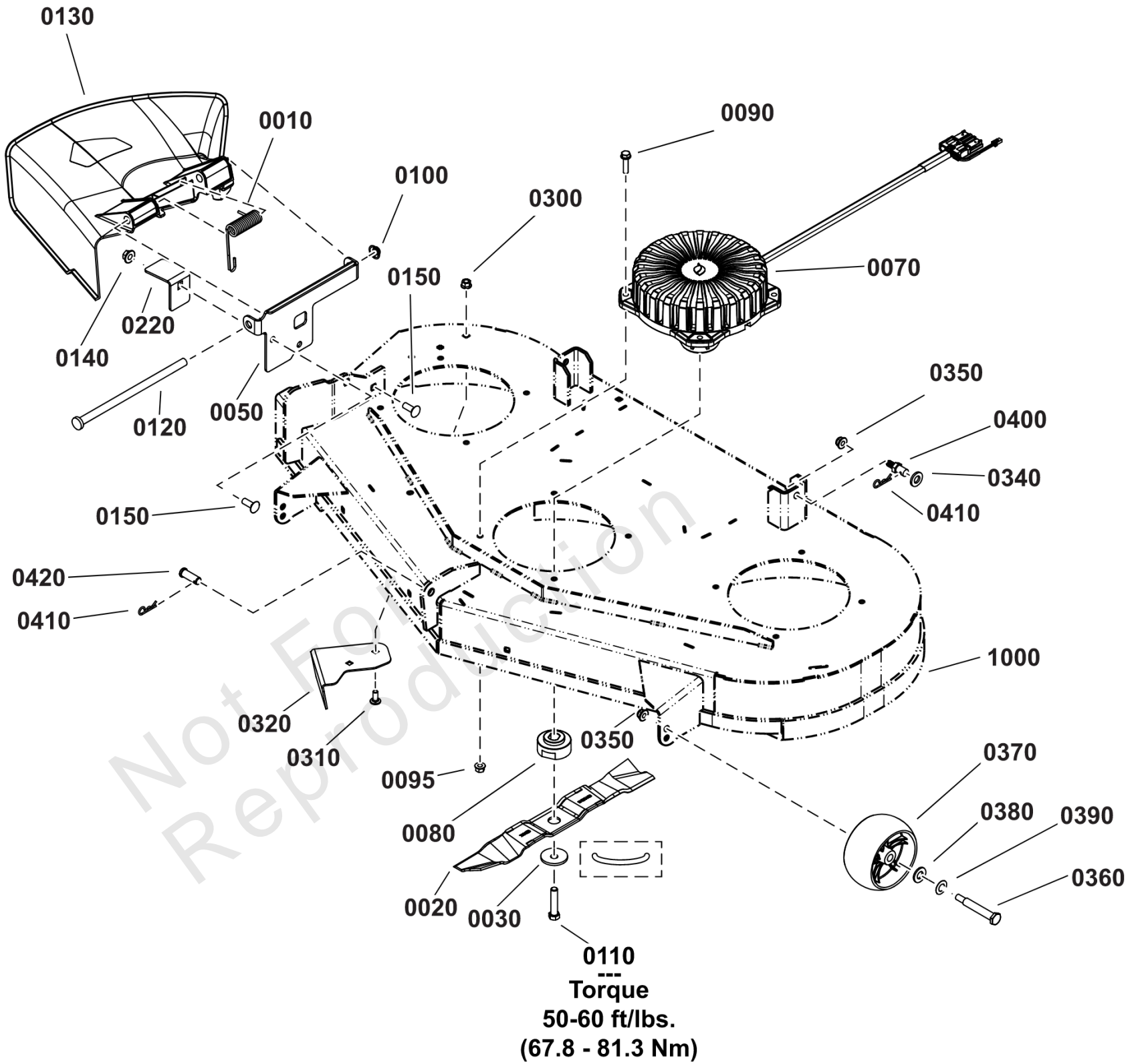

48" Mower Deck - Housing, Arbors & Blades Group

REF NO	PART NO	QTY	DESCRIPTION
0010	7035813SM	1	SPRING, TORSION, SIDE
0020	84007843	3	BLADE
0030	1656916SM	3	WASHER, SPRING 0.475I
0050	84007829	1	BRACKET
0070	84007820	3	MOTOR
0080	84007840	3	ADAPTER, Blade
0090	5023156SM	12	BOLT, 5/16-18 X 1 1/4
0095	703115	12	NUT
0100	703179	1	PUSHNUT, CAP TYPE
0110	1927531SM	3	CAPSCREW-HEX HD 7/16-
0120	7104640YP	1	ROD, Deflector
0130	7104733YP	1	CHUTE, SIDE DISCHARGE
0140	703793	2	LOCKNUT
0150	703815	2	BOLT, RD SQ 3/8-16X1
0220	1758593BMYP	1	PROP, DEFLECTOR
0300	703185	2	BOLT, Round Head, Short Square Neck
0310	703185	2	BOLT, Round Head, Short Square Neck
0320	84007830	1	BAFFLE
0340	703853	2	WASHER, 0.516IDX1OD
0350	703158	4	NUT, Hex Flange, 3/8-16
0360	1736539YP	2	BOLT, SHOULDER
0370	1736896YP	2	WHEEL, GAUGE
0380	5025158SM	2	WASHER, 1/2" SAE
0390	0020X3MA	2	WASHER, SPRING .52X.99
0400	704054	2	PIN, 3/8-16
0410	703300	3	PIN, 3/32 X 1.6
0420	5025479YP	1	CLEVIS PIN, 1/2 X 1.3
1000	-----	1	Mower Deck, 48"

Battery Group

Note: Unless noted otherwise, use the standard torque specifications

Mfg. No: 5902094

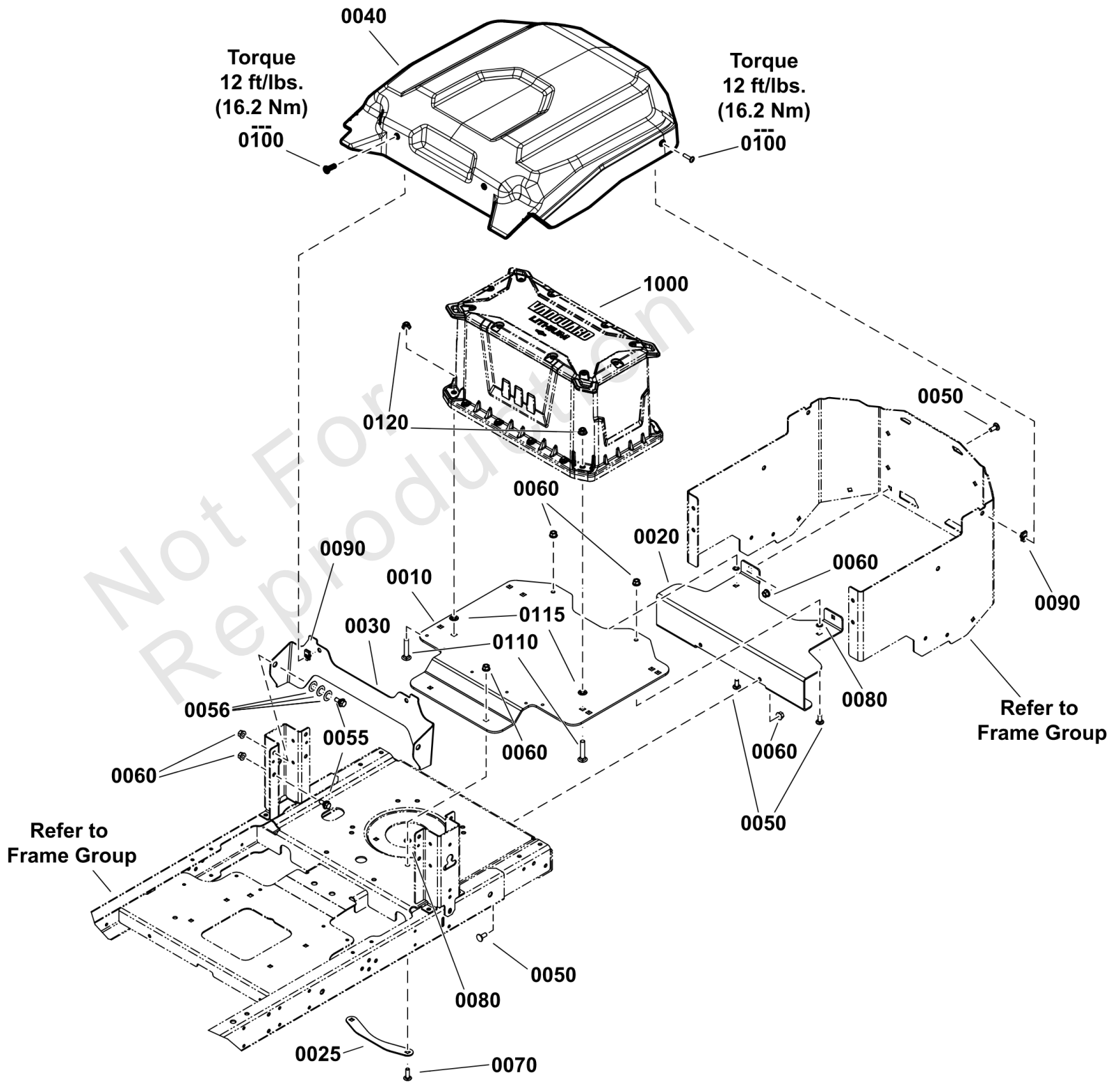

Battery Group

REF NO	PART NO	QTY	DESCRIPTION
0010	84008810	1	BRACKET, Battery
0020	84008813	1	BRACKET, Plate
0025	84008637	1	STRAP
0030	84008019	1	BRACKET, Support
0040	84007806	1	COVER
0050	703185	1	BOLT, Round Head, Short Square Neck
0055	703354	6	SCREW, 5/16-18
0056	0020X3MA	4	WASHER,SPRING .52X.99
0060	703115	4	NUT
0070	703800	12	BOLT, CRRG, 5/16-18X1
0080	703297	2	RETAINER, GR5, 5/16
0090	5022665SM	1	BODY CLIP, 1/4-20 X 1
0100	5025299X8YP	4	CAPSCREW
0110	772406	4	BOLT, Carriage, 3/8-16 x 2
0115	703986	4	RETAINER, PUSHNUT,3/8
0120	703158	4	NUT, Hex Flange, 3/8-16
1000	80110583YB01	1	BATTERY PACK, 3.5 KW

Body Group

REF NO	PART NO	QTY	DESCRIPTION
0010	84008779	1	FENDER, Right
0020	1759369YP	1	ROD, Support
0030	703953	3	SCREW, 1/4-20X5/8
0060	1758076YP	1	FENDER-LEFT
0070	84007754	2	SUPPORT, Fender
0080	84007815	1	BRACKET
0090	703228	14	SCREW, 5/16-18 X .75
0100	703158	2	NUT, Hex Flange, 3/8-16
0110	704038	2	SCREW
0120	1960044SM	4	WASHER-0.312(0.33IDX1
0130	84007977	1	COVER, Plate, LH
0140	703463	2	NUT, GR5,1/4-20

Not For Reproduction

Controls Group

Note: Unless noted otherwise, use the standard torque specifications

Mfg. No: 5902094

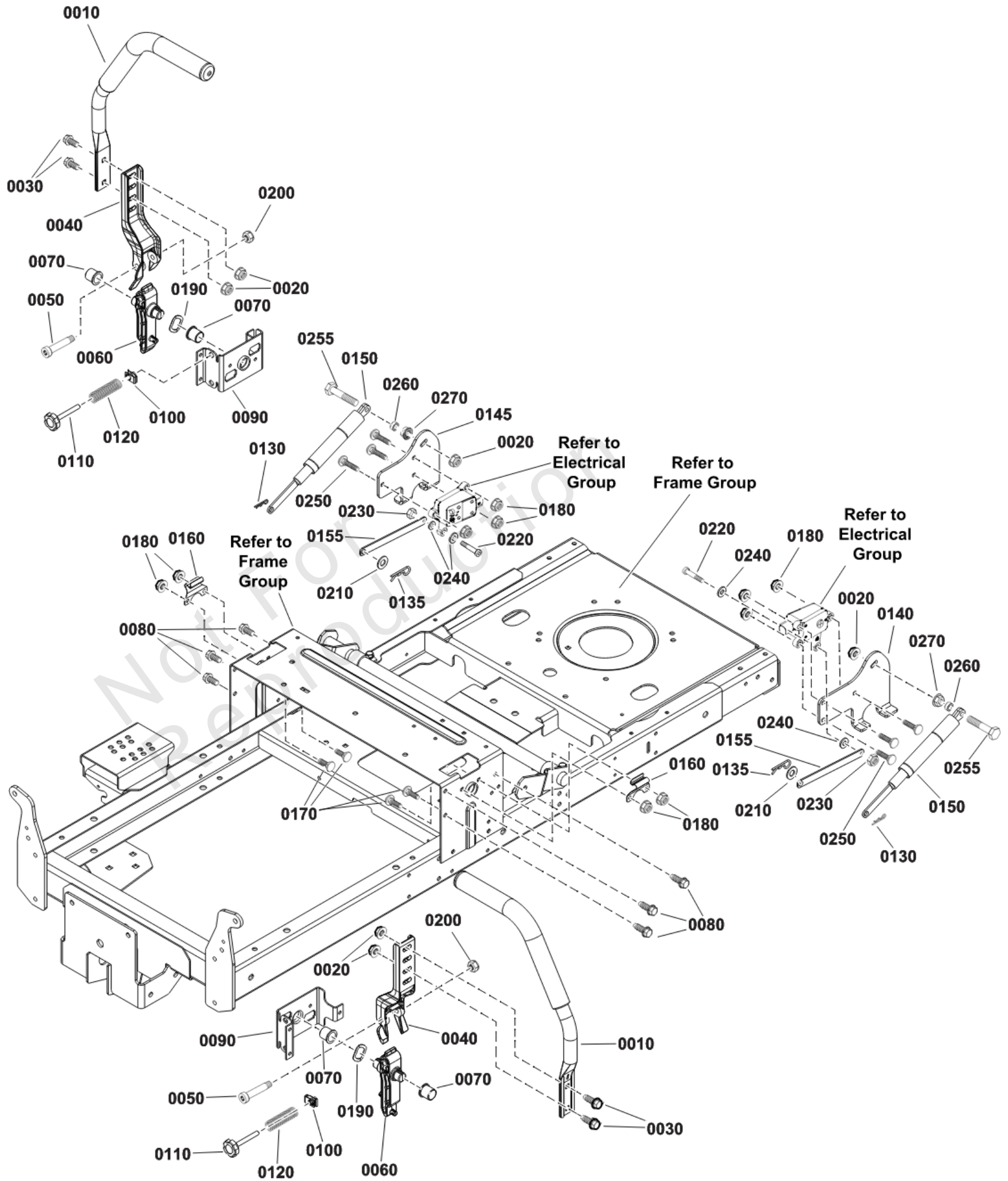

Controls Group

REF NO	PART NO	QTY	DESCRIPTION
0010	1758372YP	2	HANDLE, CONTROL
0020	703115	6	NUT
0030	703483	4	BOLT,5/16-18X1.000,RO
0040	1757965YP	2	ARM, UPPER CONTROL
0050	707624	2	BOLT,SHLDR,5/16-18
0060	1757964YP	2	ARM, LOWER CONTROL
0070	2176440SM	4	BUSHING-0.765IDX
0080	703949	6	SCREW, 5/16-18.625
0090	1758087AYP	2	PIVOT, Inner Control
0100	5022308SM	2	BODY CLIP, 5/16-18 X
0110	1758373YP	2	KNOB, 5/16-18 X 2.5
0120	1650347SM	2	SPRING-COMP 0.50 IDX
0130	5025211SM	2	PIN, HAIR, .0585" X 1
0135	703300	2	PIN, 3/32 X 1.6
0140	84007827	1	BRACKET
0145	84007826	1	BRACKET
0150	84007812	2	DAMPENER
0155	84007821	2	LINKAGE
0160	1759182YP	2	LATCH, CONTROL ARM
0170	703101	4	BOLT,1/4-20X.75
0180	703463	10	NUT, GR5,1/4-20
0190	707625	2	WSHR, 3 WAVE, .750
0200	703902	2	NUT, HEX, 5/16-18
0210	703590	2	WASHER, FLAT, .406
0220	84007822	2	BOLT
0230	703412	2	NUT, NYLOCK, 10-24
0240	84007033	4	WASHER
0250	703584	6	BOLT, 1/4-20X1, GR5
0255	704288	2	SCREW
0260	84007976	2	SPACER
0270	5025127SM	2	NUT, 5/16-18 HEX SERR

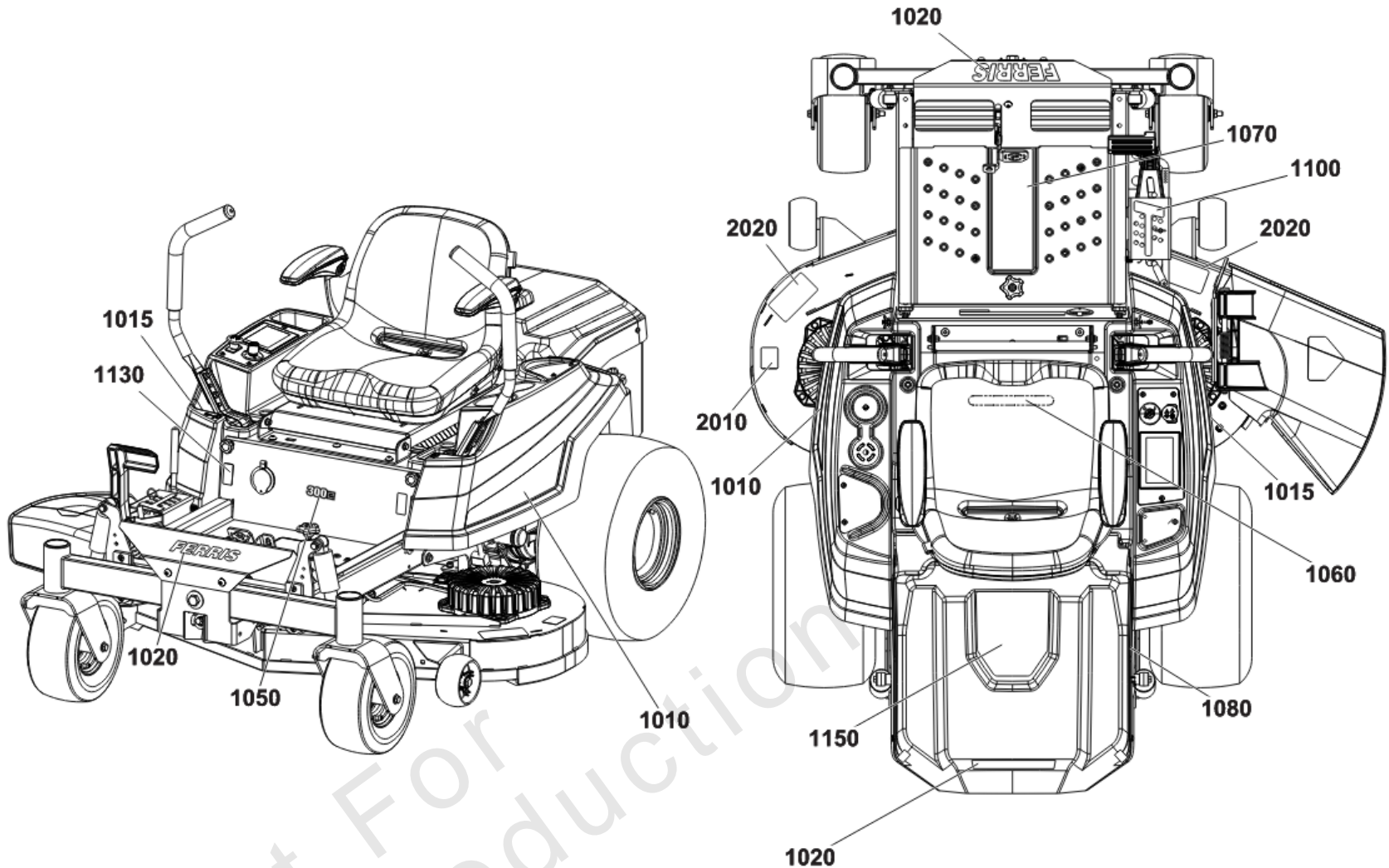

1060



1070



1080



2020

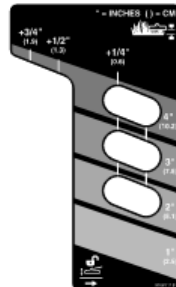

1100



1130



1010

1015



1020



1050



1150



2010



Decals Group

REF NO	PART NO	QTY	DESCRIPTION
1000	84010885		DECAL, Kit -(Incl. Ref. Nos. 1010, 1015, 1020, 1050, 1150 & 2010)
1010	80128258	1	DECAL, Ferris, Fender, L.H. -(Included with Ref. No. 1000)
1015	80128259	1	DECAL, Ferris, Fender, R.H. -(Included with Ref. No. 1000)
1020	80128776	2	DECAL, Ferris -(Included with Ref. No. 1000)
1050	80128261	1	DECAL, 300e -(Included with Ref. No. 1000)
1060	84008332	1	DECAL, Live Voltage
1070	84008348	1	DECAL, Main Safety
1080	84008349	1	DECAL, Center Plug Removal
1100	5108117FS	1	DECAL, CUTTING HEIGHT
1130	84007901	2	DECAL, Tracking Adjustment
1150	80128260	1	DECAL, Vanguard -(Included with Ref. No. 1000)
2010	80128778	1	DECAL, 42" -(Included with Ref. No. 1000)
2010	80128779	1	DECAL, 48" -(Included with Ref. No. 1000)
2020	84007896		DECAL, Danger, Cut Hand/Foot

Electrical Group - Main Wiring Harness

Note: Unless noted otherwise, use the standard torque specifications

Mfg. No: 5902094

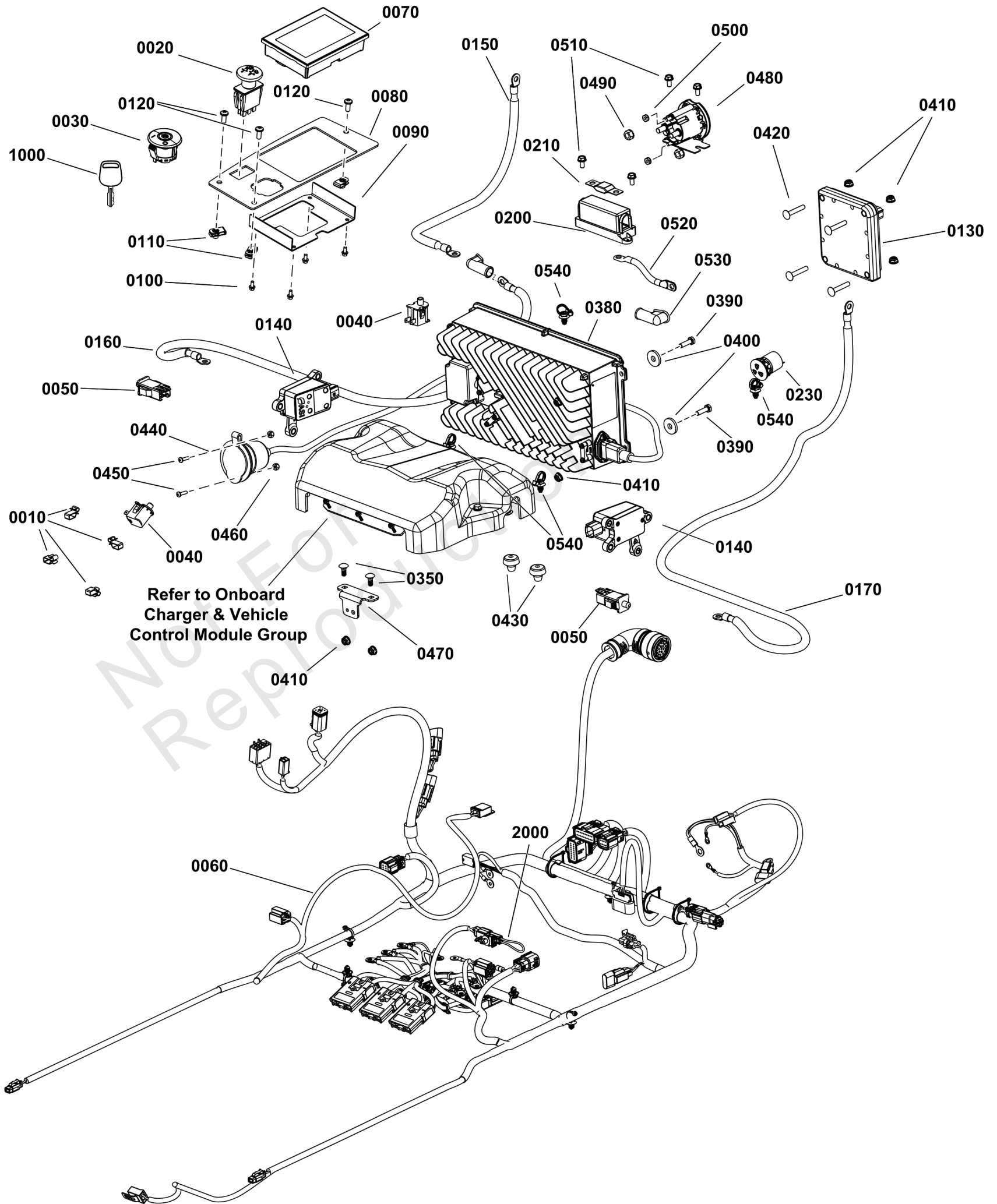

Electrical Group - Main Wiring Harness

REF NO	PART NO	QTY	DESCRIPTION
0010	2172434SM	4	CLIP- WIRE DIA .390
0020	1722887SM	1	SWITCH-PTO PUSH
0030	84008340	1	SWITCH, Ignition
0040	1732004SM	2	SWITCH-PUSH BUTTON -(Used as Brake Switch and Seat Switch)
0050	7022886YP	2	SWITCH, DP NO/NC SNAP
0060	84007811	1	HARNESS, Wiring -(Incl. Ref. No. 2000)
0070	84007852	1	DISPLAY -(Uses Firmware 80128522)
0070-01	6903	1	KIT, PROGRAMMING, DISPLAY -(Dealer Service Item Only)
0080	84007804	1	PANEL, Control
0090	84007802	1	BRACKET
0100	2860707SM	4	SCREW-HEX SERR FLNG L
0110	5022665SM	3	BODY CLIP, 1/4-20 X 1
0120	703953	3	SCREW, 1/4-20X5/8
0130	84007816	1	Vehicle Control Module
0140	84007817	2	THROTTLE, Sensor
0150	84007784	1	CABLE, Power
0160	84008324	1	CABLE, Power
0170	84007813	1	CABLE, Battery, Black
0200	84008333	1	HOLDER, Fuse
0210	84008331	1	FUSE
0230	84007994	1	BEEPER
0350	1960252SM	6	BOLT-RD HD SH SQ NK 1
0380	84007803	1	CHARGER, Battery
0390	703819	4	CAPSCREW, 1/4-20X0.875
0400	703298	4	WASHER, 5/16
0410	703463	14	NUT, GR5, 1/4-20
0420	704214	4	BOLT, 1/4-20 X 1.5
0430	197546GS	2	MOUNT-VIBRATION
0440	84007809	1	RECEPTACLE
0450	84007579	2	SCREW, PPHMS 8-32 x .625
0460	5025339YP	2	NUT
0470	----	1	BRACKET, 48V Disconnect
0480	84007604	1	CONTACTOR
0490	2860750SM	2	NUT-HEX KEPS 5/16-24
0500	1928919SM	2	NUT-HEX & WASHER ASMY
0510	708964	4	SCREW
0520	84008325	1	CABLE, Power
0530	1713535SM	2	BOOT, Insulator, Red
0540	770536	3	WIRE TIE, Rosebud
1000	7106170YP	1	KEY, Ignition Switch, Pack of 2, NA/AU
2000	84008341	1	HARNESS, Jumper -(Included with Ref. No. 0060)

Electrical Group - Onboard Charger and Vehicle Control Module

Note: Unless noted otherwise, use the standard torque specifications

Mfg. No: 5902094

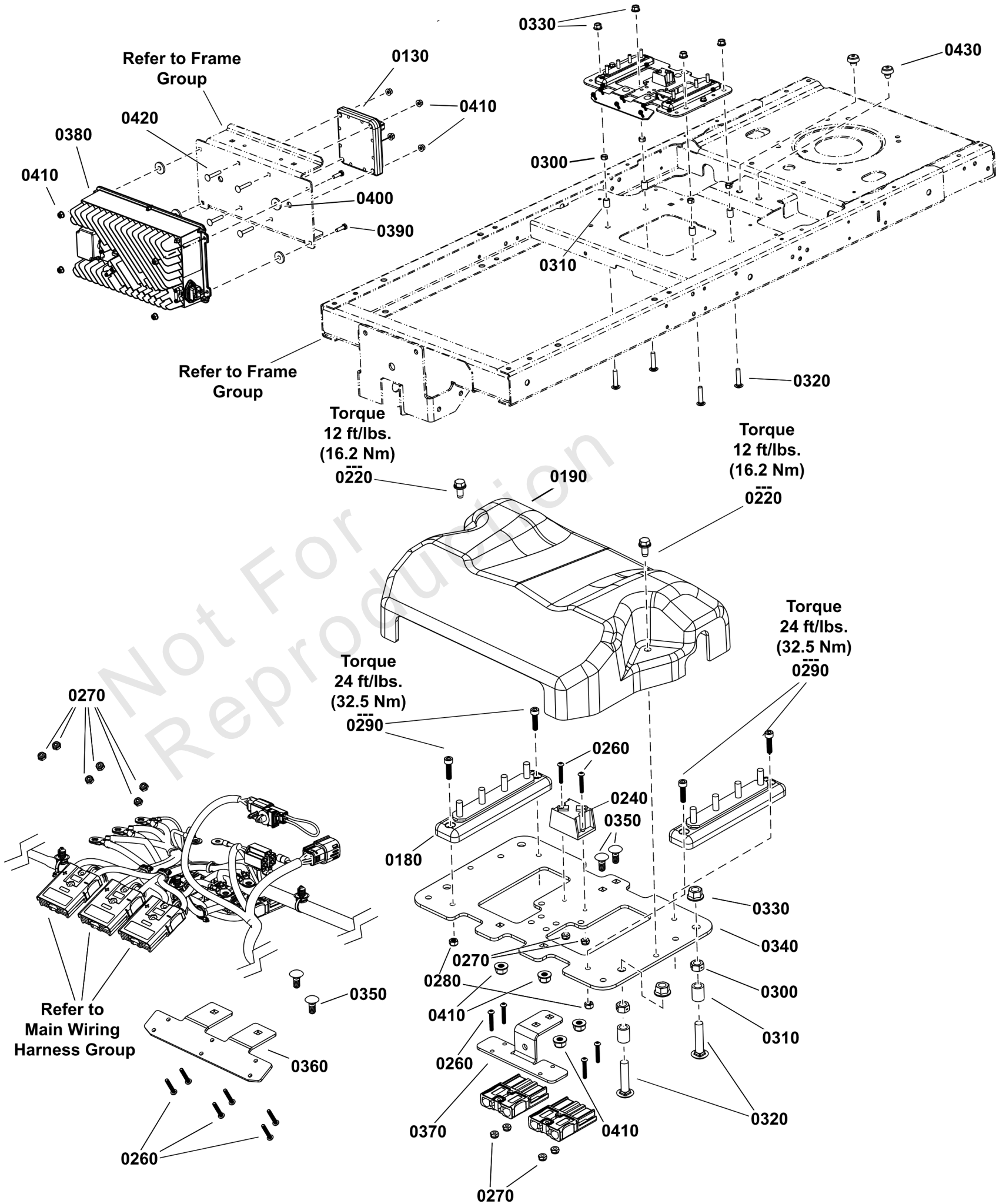

Electrical Group - Onboard Charger and Vehicle Control Module

REF NO	PART NO	QTY	DESCRIPTION
0130	84007816	1	Vehicle Control Module
0180	84007810	2	BAR, Bus
0190	84007805	1	COVER, Terminal
0220	704130	2	SCREW, HEX, 1/4-20X.5
0240	84007807	1	DIODE
0260	84008326	12	SCREW
0270	703915	12	NUT, HEX, #6-32
0280	84007034	4	NUT, Hex, M5X.8MM, Nylon Insert
0290	84008351	4	CAPSCREW
0300	703164	4	NUT
0310	1710703SM	4	SPACER, 3/8 x 1/2 x 5/8
0320	703296	4	BOLT, 5/16-18X1.5
0330	703115	4	NUT
0340	84008817	1	PLATE ASSEMBLY
0350	1960252SM	6	BOLT-RD HD SH SQ NK 1
0360	84008818	1	PLATE ASSEMBLY
0370	84008819	1	PLATE
0380	84007803	1	CHARGER, Battery
0390	703819	4	CAPSCREW, 1/4-20X0.875
0400	703298	4	WASHER, 5/16
0410	703463	14	NUT, GR5, 1/4-20
0420	704214	4	BOLT, 1/4-20 X 1.5
0430	197546GS	2	MOUNT-VIBRATION

Frame Group

Note: Unless noted otherwise, use the standard torque specifications

Mfg. No: 5902094

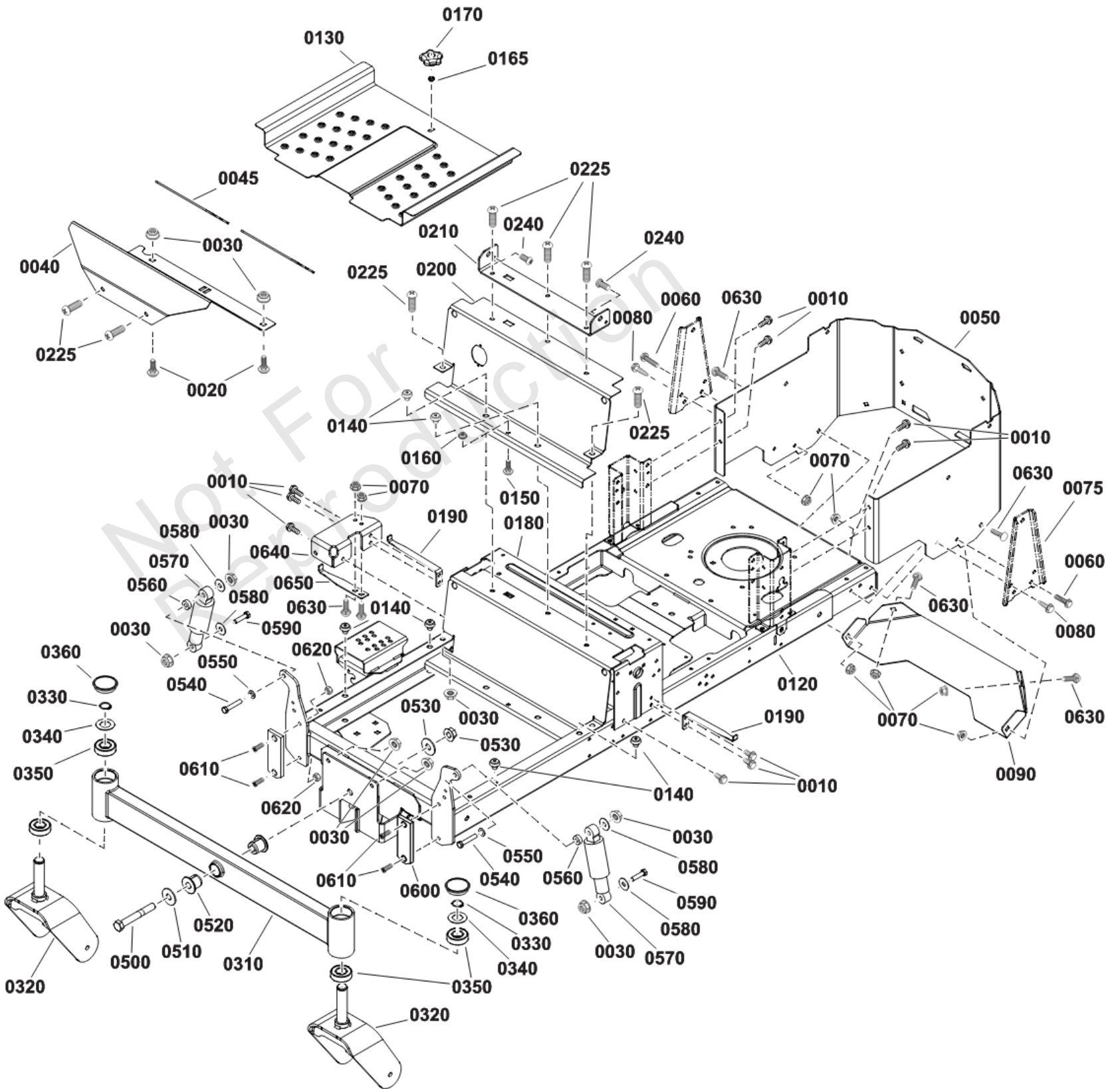

Frame Group

REF NO	PART NO	QTY	DESCRIPTION
0010	703949	10	SCREW, 5/16-18.625
0020	703448	2	BOLT, 3/8-16X.75 G5
0030	703158	13	NUT, Hex Flange, 3/8-16
0040	84008816	1	FOOTREST
0045	5101004SM	2	SAFETY WALK
0050	84008815	1	BUMPER, Rear
0060	703410	2	BOLT,5/16-18X1
0070	703115	8	NUT -(Qty. 6 with 42" Model)
0075	84008811	2	MOUNT
0080	703228	2	SCREW, 5/16-18 X .75
0090	84007842	1	BRACKET
0120	-----	1	FRAME
0130	1757813CYP	1	PAN, Foot
0140	197546GS	6	MOUNT-VIBRATION
0150	7090496YP	1	RHSSNB, 1/4C X1 GR5 Z
0160	703233	1	NUT, 1/4-20, GR5
0165	15X143MA	1	NUT,25-20 HEX FLG CTR
0170	707785	1	KNOB
0180	84007065	1	CONTROL BRACKET
0190	1758240AYP	1	BRACKET, Fender -(Qty. 2 with 42" Model)
0200	84008812		BRACKET, Support
0210	1760193CYP	1	BRACKET, Seat
0225	84004627	7	CAPSCREW
0240	703932	2	SCREW, 5/16-18X.5
0310	1761505CYP	1	AXLE, Front, Pivoting
0320	80081658BFS	2	CASTER
0330	703993	2	RETAINER, EXT RING, 1
0340	703199	2	WASHER, 1
0350	1758354YP	4	BEARING
0360	5105524YP	2	CAP
0500	707789	1	BOLT
0510	1960035SM	2	WASHER-0.625(0.64IDX1
0520	1759234YP	2	BUSHING
0530	84003031	1	NUT
0540	703589	2	CAPSCREW, 3/8-16X2
0550	703590	2	WASHER, FLAT, .406
0560	1667811SM	2	SPACER
0570	1755279YP	2	SHOCK ABSORBER, 8IN
0580	5025165	4	WASHER, 3/8" Fender
0590	703406	2	CAPSCREW,3/8-16X1.5
0600	1759391YP	2	PAD-FRICTION
0610	5025594YP	4	SCREW, 5/16-18 X 1
0620	703590	4	WASHER, FLAT, .406
0630	703185	6	BOLT, Round Head, Short Square Neck -(Qty. 4 with 42" Model)
0640	84007993	1	BRACKET -(48" Model Only)
0650	1760283YP	1	BRACE, Fender -(48" Model Only)

Lift Group

Note: Unless noted otherwise, use the standard torque specifications

Mfg. No: 5902094

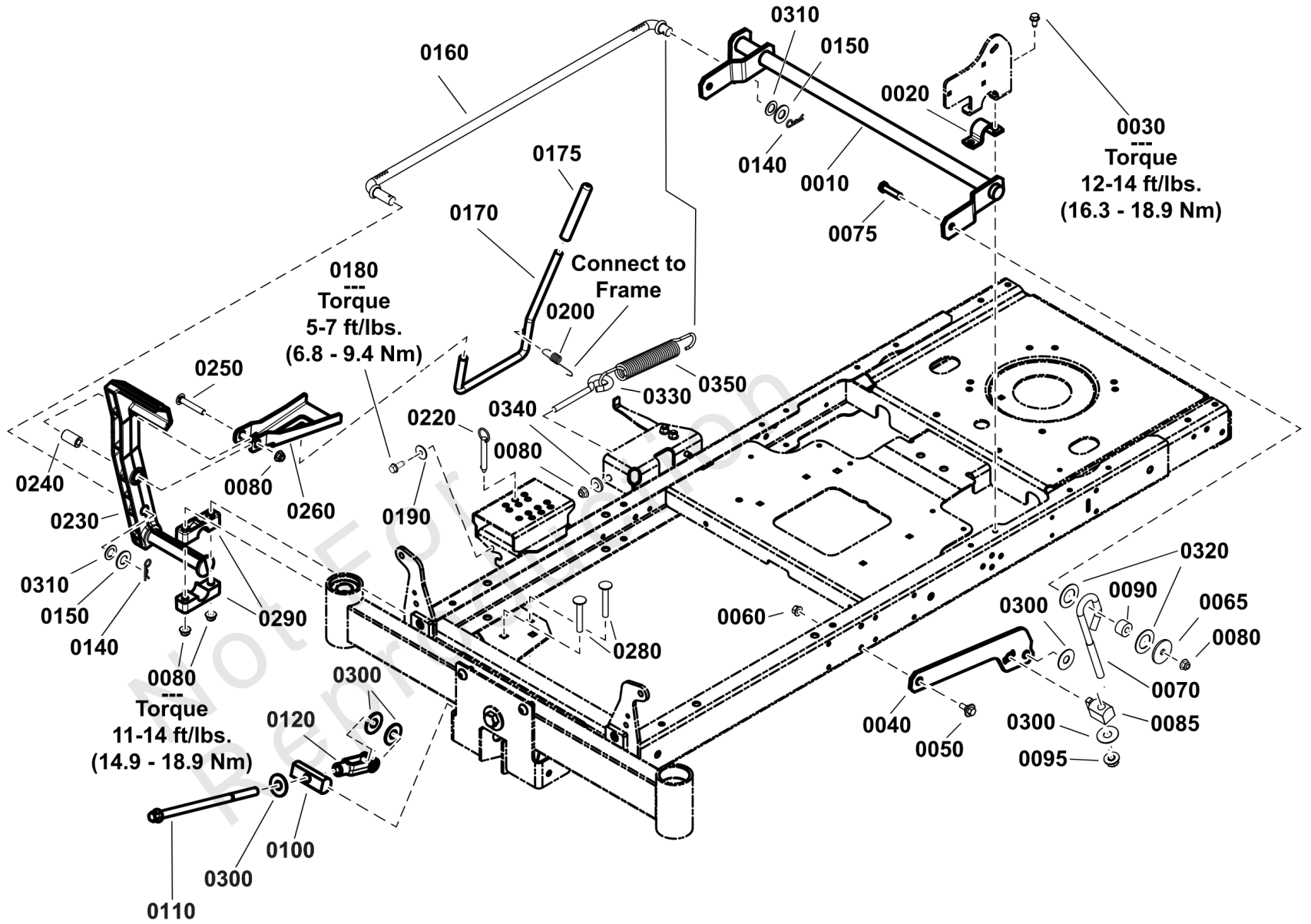

Lift Group

REF NO	PART NO	QTY	DESCRIPTION
0010	1757958AYP	1	SHAFT
0020	1720147BZYP	2	STRAP, 1 IN. DIA
0030	703949	4	SCREW, 5/16-18.625
0040	84007844	2	ARM
0050	1732426SM	2	BOLT-SHLDR 5/16-18 0.
0060	703115	2	NUT
0065	5025305SM	2	WASHER, .41 X 1.75 X
0070	84003818	2	ROD, Lift
0075	703406	2	CAPSCREW,3/8-16X1.5
0080	703158	8	NUT, Hex Flange, 3/8-16
0085	84003820	2	TRUNNION
0090	5100334SM	2	SPACER
0095	770225	2	NUT
0100	1757955YP	1	PIVOT
0110	1757954YP	1	ROD
0120	5023174SM	1	CLEVIS, 1/2-20, STEEL
0140	703300	2	PIN, 3/32 X 1.6
0150	5025281SM	1	WASHER, 5/8" SAE -(42" Model Only)
0160	1758121YP	1	ROD
0170	5105717YP	1	ROD
0175	5021880SM	1	GRIP, FOAM
0180	703054	2	SCREW, 1/4-20X0.625
0190	5025288YP	2	WASHER, 1/4 FENDER
0200	1758283YP	1	SPRING, EXTENSION
0220	5103021YP	1	HITCH PIN, 3/8 X 2-1/
0230	1758232YP	1	PEDAL
0240	1756612YP	1	BUSHING, DIFF. LOCK
0250	7900009SM	1	RHSSNB, 3/8-16 X 2-1/
0260	1758284AYP	1	BRACKET
0280	1960615SM	4	BOLT-RD HD SQ NK 3/8
0290	5100634SM	4	PIVOT BLOCK, PLASTIC
0300	1716998SM	7	WASHER, Special, 0.575ID X 1.50 OD X.06
0310	84007849	1	WASHER -(42" Model Only)
0320	84007850	4	WASHER
0330	5023497SM	1	EYE BOLT, 3/8-16 X 5" -(48" Model Only)
0340	704128	1	WASHER -(48" Model Only)
0350	1760160YP	1	SPRING, Extension -(48" Model Only)

Parking Brake Group

Note: Unless noted otherwise, use the standard torque specifications

Mfg. No: 5902094

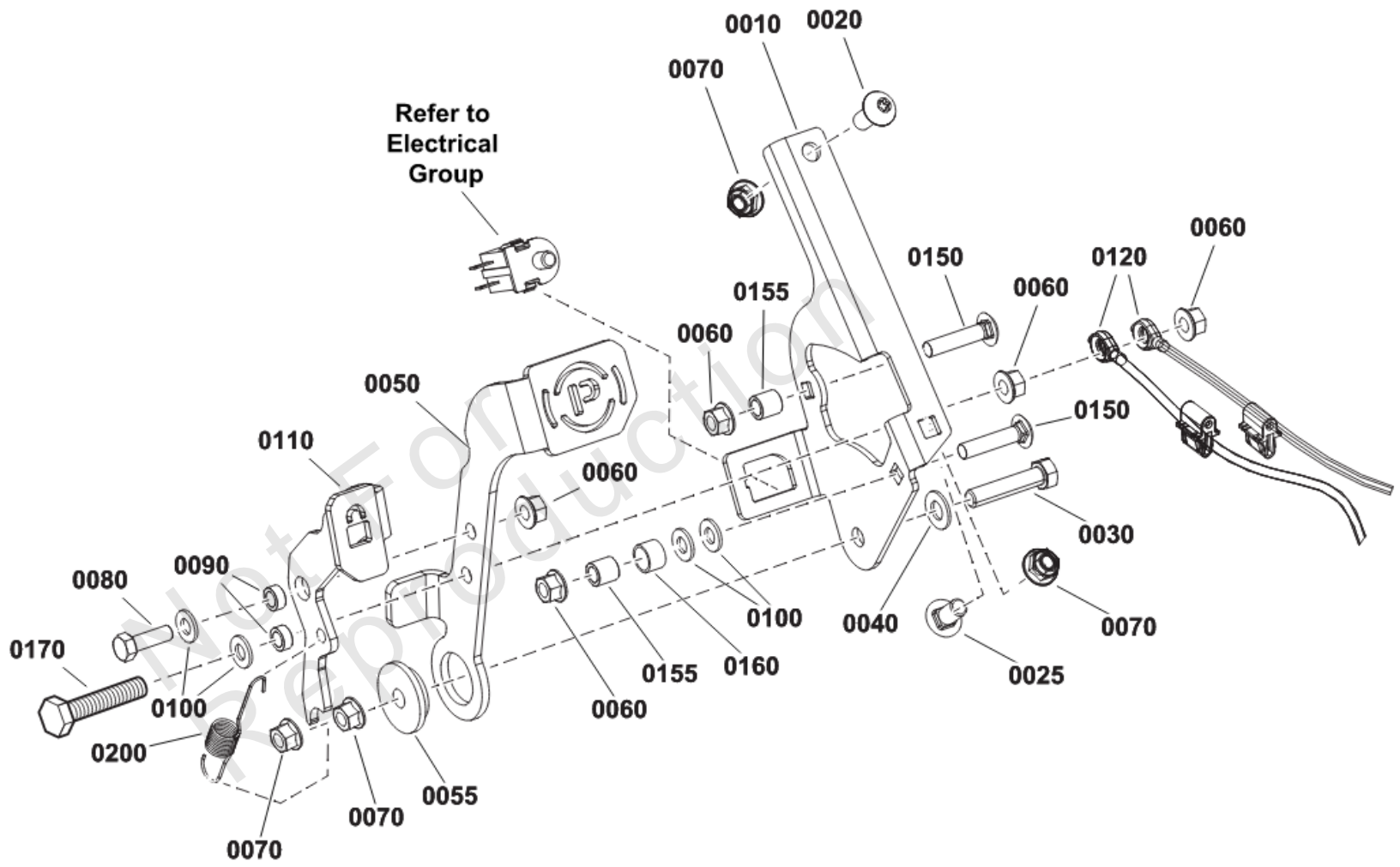

Parking Brake Group

REF NO	PART NO	QTY	DESCRIPTION
0010	84007837	1	BRACKET, Mounting
0020	84004627	1	CAPSCREW
0025	703448	1	BOLT, 3/8-16X.75 G5
0030	5025058X14YP	1	BOLT 3/8-16 X 1-3/4
0040	7090122YP	1	WASHER, Flat, 3/8 (SAE)
0050	84007833	1	BRACKET, Brake
0055	1714255SM	1	SPACER, .406" ID, 1.50" OD, .350" Thick, PM
0060	703115	5	NUT
0070	703158	4	NUT, Hex Flange, 3/8-16
0080	703585	1	CAPSCREW, 5/16-18X1
0090	84007976	2	SPACER
0100	703350	4	WASHER
0110	84007836	1	BRACKET
0120	84007831	2	CABLE, Brake
0150	703296	2	BOLT, 5/16-18X1.5
0155	5102148YP	2	SPACER, .33 X .50X.50
0160	84007823	1	SLEEVE
0170	5025055X18YP	1	BOLT, 5/16-18 X 2-1/4
0200	1758283YP	3	SPRING, EXTENSION

Rear Suspension Group

Note: Unless noted otherwise, use the standard torque specifications

Mfg. No: 5902094

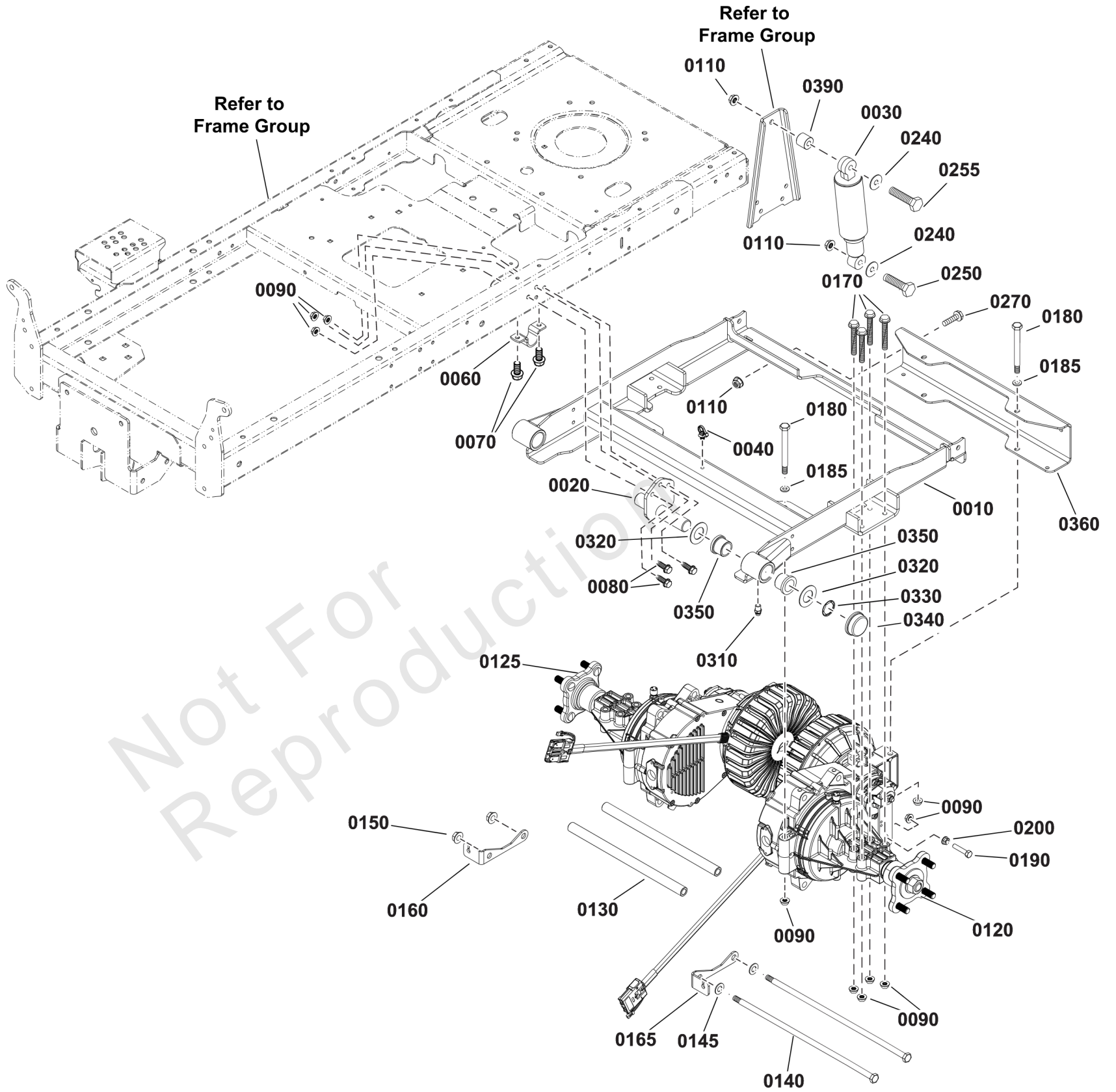

Rear Suspension Group

REF NO	PART NO	QTY	DESCRIPTION
0010	84008820	1	WELDMENT, Transmission Carrier
0020	84008821	2	WELDMENT, Swing Arm Pivot
0030	1755531YP	2	*ABSORBER, Shock
0040	770536	1	WIRE TIE, Rosebud
0060	1720147BZYP	2	STRAP, 1 IN. DIA
0070	703949	4	SCREW, 5/16-18.625
0080	1960667SM	6	SCREW-HEX WZ LOCK FLN
0090	703115	20	NUT
0110	703158	6	NUT, Hex Flange, 3/8-16
0120	-----	1	TRANSMISSION, L.H. -(Refer to Note: *)
0125	-----	1	TRANSMISSION, R.H. -(Refer to Note: *)
0130	84007846	2	SPACER
0140	84007847	2	CAPSCREW
0145	703183	2	WASHER, 7/16 ID X.065
0150	1930650SM	2	NUT-HEX FLANGE 7/16-1
0160	84007825	1	BRACKET, Brake
0165	84007824	1	BRACKET, Brake
0170	707943	8	SCREW
0180	84007808	4	SCREW
0185	703350	4	WASHER
0190	5025011X12SM	2	BOLT, 5/16-18 X 1-1/2
0200	5025127SM	2	NUT, 5/16-18 HEX SERR
0240	5025165SM	4	WASHER, 3/8" FENDER
0250	5025013X14SM	2	BOLT, 3/8-16 X 1-3/4"
0255	84007037	2	BOLT
0270	704038	2	SCREW
0310	1704314SM	2	LUBE FITTING, .250 DR
0320	703199	4	WASHER, 1
0330	703200	2	PUSHNUT
0340	094618MA	2	HUB CAP
0350	1758717YP	4	BUSHING
0260	-----	1	BRACKET, Support
0390	5047125SM	2	SPACER, .39 X 1.00 X

Footnotes:

Note:* Refer to Transmission Service Parts Group.

Seat Group

Note: Unless noted otherwise, use the standard torque specifications

Mfg. No: 5902094

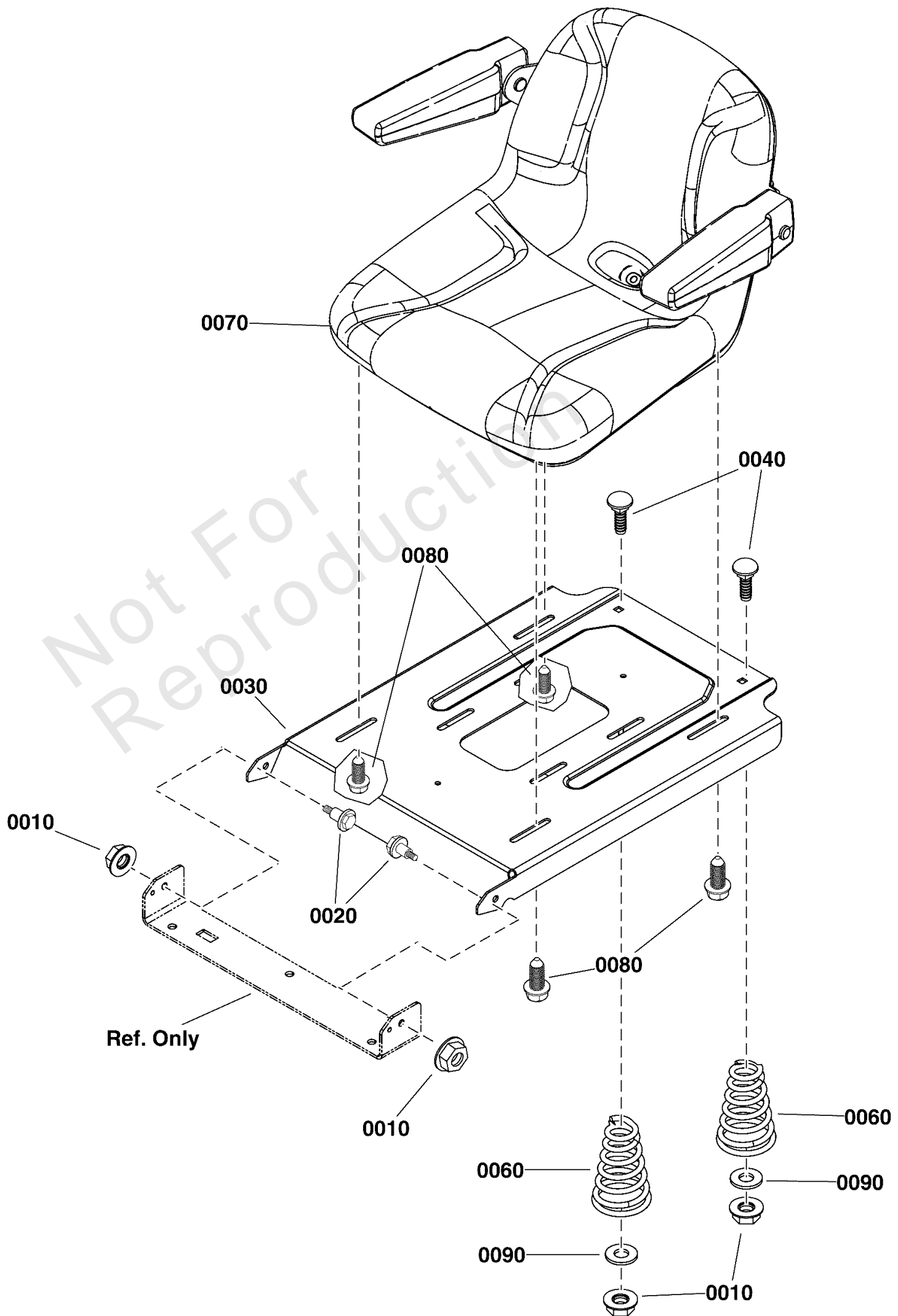

Seat Group

REF NO	PART NO	QTY	DESCRIPTION
0010	5025392FS	4	NUT
0020	1752802YP	2	BOLT, SHLDR, 5/16-18
0030	84001620	1	SLIDE, SEAT
0040	703483	2	BOLT,5/16-18X1.000,RO
0060	1717051SM	2	SPRING, Seat
0070	84008822	1	SEAT ASSEMBLY w/Armrests
0080	1960667SM	4	SCREW-HEX WZ LOCK FLN
0090	703591	4	WASHER, .406X1.5X.12

Not For Reproduction

Transmission Service Parts

Note: Unless noted otherwise, use the standard torque specifications

Mfg. No: 5902094

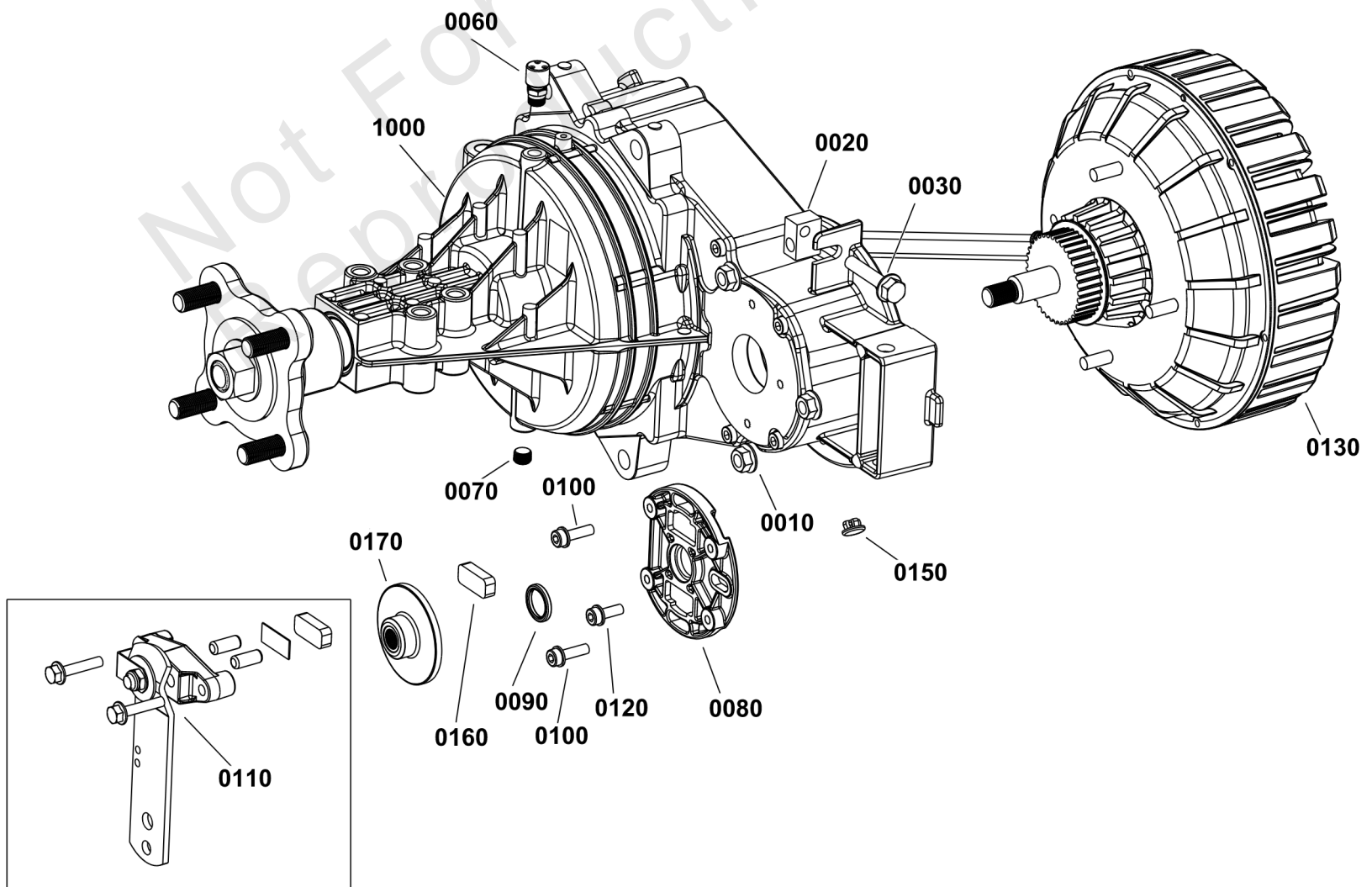
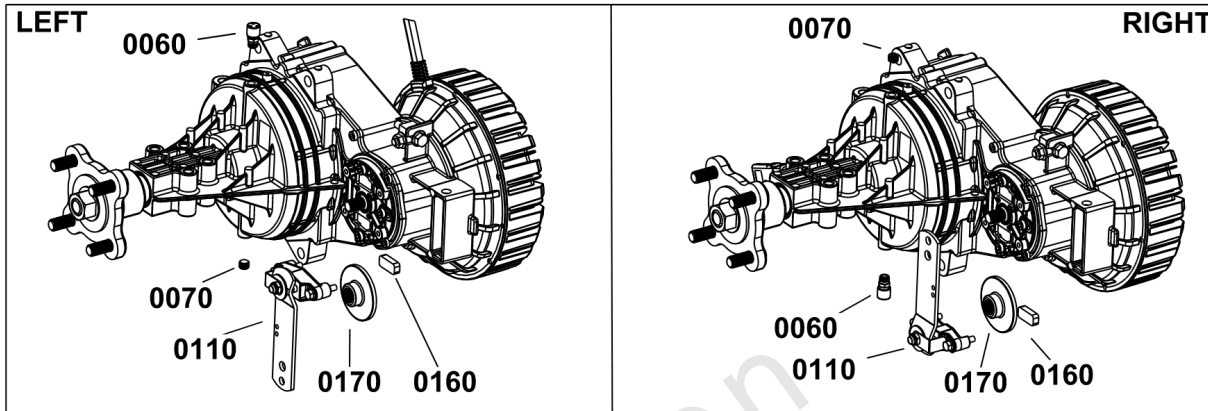

Transmission Service Parts

REF NO	PART NO	QTY	DESCRIPTION
0010	67989GS	3	NUT, M8 Flange Serrated
0020	84007796	1	TENSIONER
0030	84007795	1	BOLT
0060	84007792	1	BREATHER
0070	84007791	1	PLUG
0080	84007790	1	ADAPTER
0090	84007788	1	SEAL
0100	84007787	2	SCREW, Flange
0110	84007782	1	BRAKE
0120	84007785	1	SCREW
0130	84007832	1	MOTOR -(Includes Studs, size M8)
0150	84007786	1	PLUG, Hole
0160	84007956	1	PAD, Brake
0170	84007957	1	DISK
1000	84008296	1	TRANSMISSION, Assembly

Not For Reproduction

Wheel & Tire Group

Note: Unless noted otherwise, use the standard torque specifications

Mfg. No: 5902094

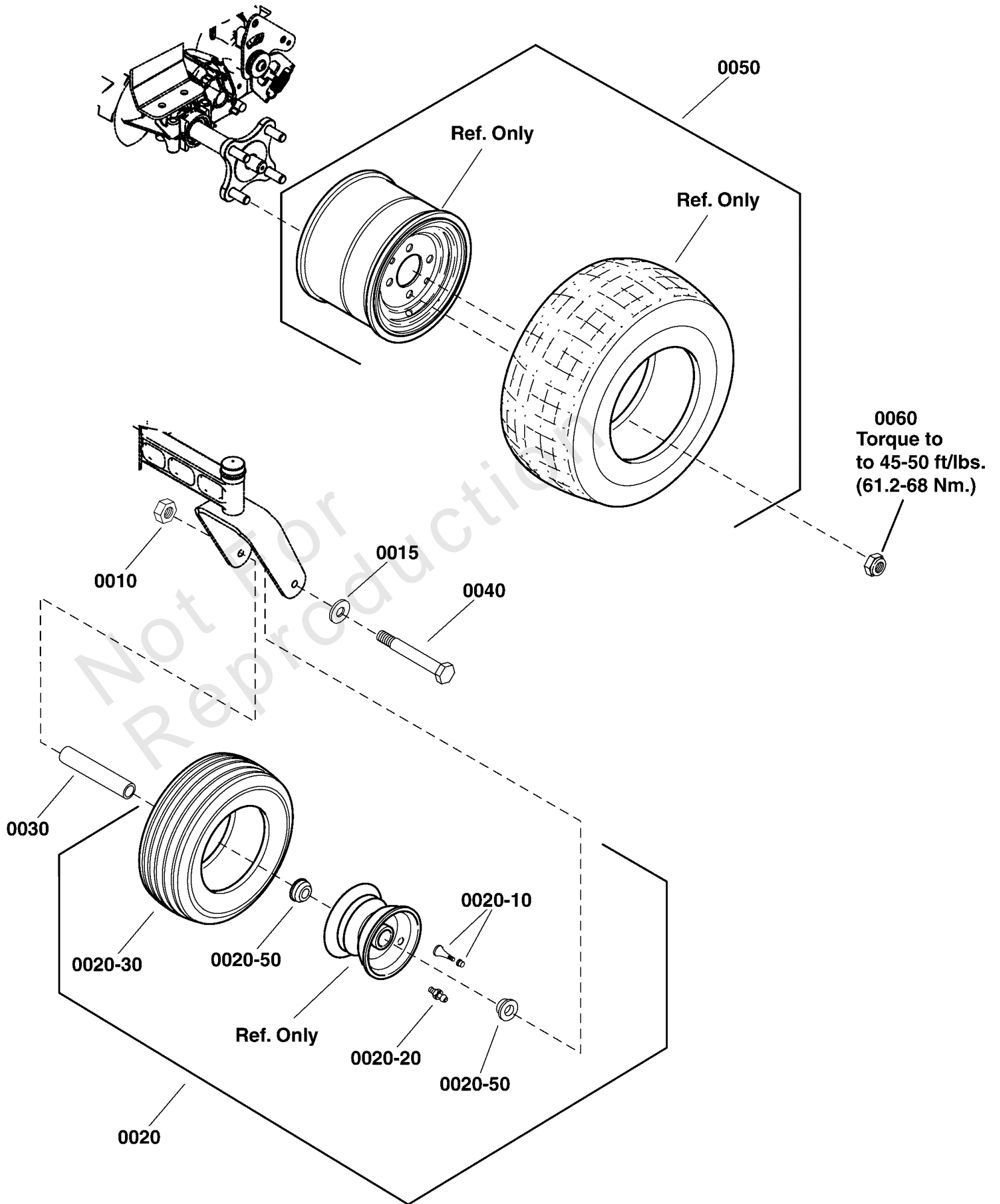

Wheel & Tire Group

REF NO	PART NO	QTY	DESCRIPTION
0010	1930650SM	2	NUT-HEX FLANGE 7/16-1
0015	703183	2	WASHER, 7/16 ID X.065
0020	5109054FS	2	TIRE ASSEMBLY
0020-10	2172353SM	4	VALVE STEM & CAP
0020-20	7104428YP	2	ZERK, Grease
0020-30	84004709	2	TIRE
0020-50	84003829	4	BEARING, BALL
0030	1734841SM	2	SPACER - CASTER
0030	84003827	2	TUBE, Caster Wheel
0040	84003828	2	CAPSCREW
0050	84008371	2	TIRE ASSEMBLY
0060	5020601SM	8	NUT, 1/2-20, FOR WHEEL BOLT SILVER

Not For Reproduction

Hardware Identification & Torque Specifications

Torque Specification Chart								
FOR STANDARD METRIC MACHINE HARDWARE (Tolerance ± 20%)								
Property Class	5.6		8.8		10.9		12.9	
	Class 5.6		Class 8.8		Class 10.9		Class 12.9	
Size Of Hardware	in/lbs	Nm.	in/lbs	Nm.	in/lbs	Nm.	in/lbs	Nm.
	ft/lbs		ft/lbs		ft/lbs		ft/lbs	
M3	5.88	.56	13.44	1.28	19.2	1.80	22.92	2.15
M4	13.44	1.28	30.72	2.90	43.44	4.10	52.56	4.95
M5	26.4	2.50	60.96	5.75	5.97	8.10	7.15	9.7
M6	44.64	4.3	7.3	9.9	10.3	14	12.1	16.5
M7	5.2	7.1	12.1	16.5	16.9	23	19.9	27
M8	7.7	10.5	17.7	24	25	34	29	40
M10	15	21	35	48	50	67	59	81
M12	26	36	61	83	86.2	117	103	140
M14	42	58	101	132	136	185	162	220
M16	64	88	147	200	210	285	250	340
M18	89	121	202	275	287	390	346	470
M20	126	171	290	390	405	550	486	660
M22	169	230	390	530	559	745	656	890
M24	217	295	497	375	708	960	840	1140
M27	320	435	733	995	1032	1400	1239	1680
M30	435	590	995	1350	1401	1900	1681	2280
M33	590	800	1349	1830	1902	2580	2278	3090
M36	759	1030	1740	2360	2441	3310	2935	3980
M39	988	1340	2249	3050	3163	4290	3798	5150

Torque Specification Chart						
FOR STANDARD MACHINE HARDWARE (Tolerance ± 20%)						
Hardware Grade	No Marks		SAE Grade 5		SAE Grade 8	
	SAE Grade 2		SAE Grade 5		SAE Grade 8	
Size Of Hardware	in/lbs	Nm.	in/lbs	Nm.	in/lbs	Nm.
	ft/lbs		ft/lbs		ft/lbs	
8-32	19	2.1	30	3.4	41	4.6
8-36	20	2.3	31	3.5	43	4.9
10-24	27	3.1	43	4.9	60	6.8
10-32	31	3.5	49	5.5	68	7.7
1/4-20	66	7.6	8	10.9	12	16.3
1/4-28	76	8.6	10	13.6	14	19.0
5/16-18	11	15.0	17	23.1	25	34.0
5/16-24	12	16.3	19	25.8	29	34.0
3/8-16	20	27.2	30	40.8	45	61.2
3/8-24	23	31.3	35	47.6	50	68.0
7/16-14	30	40.8	50	68.0	70	95.2
7/16-20	35	47.6	55	74.8	80	108.8
1/2-13	50	68.0	75	102.0	110	149.6
1/2-20	55	74.8	90	122.4	120	163.2
9/16-12	65	88.4	110	149.6	150	204.0
9/16-18	75	102.0	120	163.2	170	231.2
5/8-11	90	122.4	150	204.0	220	299.2
5/8-18	100	136	180	244.8	240	326.4
3/4-10	160	217.6	260	353.6	386	525.0
3/4-16	180	244.8	300	408.0	420	571.2
7/8-9	140	190.4	400	544.0	600	816.0
7/8-14	155	210.8	440	598.4	660	897.6
1-8	220	299.2	580	788.8	900	1,244.0
1-12	240	326.4	640	870.4	1,000	1,360.0

The guides and ruler furnished below are designed to help you select the appropriate hardware.



Nut, M8

Thread Diameter (mm)

Inside Diameter (in) Threads per inch

Nut, 1/2-16



Screw, M8- 1.25 x 25

Thread Diameter (mm) Distance between threads (mm) Body Length (mm)

Body Diameter Threads per inch Body Length (in)

Screw, 1/2- 16 x 2



Standard Hardware Sizing

When a washer or nut is identified as 1/2" (M8), this is the *Nominal size*, meaning the *inside diameter* is 1/2 inch (8mm metric thread diameter); if a second number is present it represents the *threads per inch* (distance between threads).

When bolt or capscrew is identified as 1/2 - 16 x 2" (M8 - 1.25 x 50), this means the *Nominal size*, or body diameter is 1/2 inch (8mm metric thread diameter), the second number, 16, represents the *threads per inch*, (*distance between threads*). The final number is the body length of the bolt or screw, 2 inches (50mm).

NOTES

- These torque values are to be used for all hardware excluding: locknuts, self-tapping screws, thread forming screws, sheet metal screws and socket head setscrews.
- Recommended seating torque values for locknuts:
 - for prevailing torque locknuts - use 65% of grade 5 torques.
 - for flange whizlock nuts and screws - use 135% of grade 5 torques.
- Unless otherwise noted on assembly drawings, all torque values must meet this specification.

Common Hardware Types

Hex Head Capscrew



Washer



Carriage Bolt



Hex Nut

Wrench & Fastener Size Guide

1/4" Bolt or Nut Wrench—7/16"	5/16" Bolt or Nut Wrench—1/2"	3/8" Bolt or Nut Wrench—9/16"	7/16" Bolt or Nut Wrench (Bolt)—5/8" Wrench (Nut)—11/16"	1/2" Bolt or Nut Wrench—3/4"
M6 Bolt or Nut Wrench—10mm	M8 Bolt or Nut Wrench—13mm	M10 Bolt or Nut Wrench—17mm	M12 Bolt or Nut Wrench—19mm	M14 Bolt or Nut Wrench—22mm

